

Features

- General Purpose Enclosure
- 2-way normally closed or normally open operation
- Zero differential lever actuated
- For on-off control of fuel oil in commercial and industrial oil burners
- Suitable for light and heavy fuel oils

Fluid

- No. 2 Fuel Oil at 60 SSU
- No. 4 Fuel Oil at 300 SSU
- No. 5 Fuel Oil at 5000 SSU
- No. 6 Fuel Oil at 5000 SSU (Heated)

Construction

Valve Parts in Contact with Fluids	
Body	Brass
Seals and Disc	FKM (Suffix V), SS (Suffix L)
Core and Plugnut	430F Stainless Steel
Springs	302 Stainless Steel
Shading Coil	Copper

Electrical

Standard Coil and Class of Insulation	Watt Rating and Power Consumption			Spare Coil Family		
	AC			General Purpose		
	Watts	VA Holding	VA Inrush	24/60	120/60 110/50	240/60 220/50
F	15.4	27	160	099257	099257	099257
F	20	43	240	099257	099257	099257

Standard lead length 18" (72" leads optional - change suffix "D" to "K").

Solenoid Enclosures

- Standard:** RedHat Type 1 General Purpose.
Optional: RedHat Type 3R Rainproof (prefix "R").

Valve Response Time

Opening Time: Less than 1 second; **Closing Time:** Less than 1 second

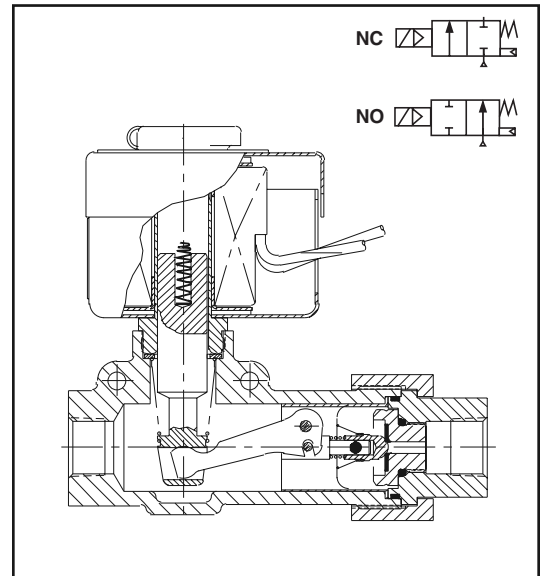

Approvals

(Normally Closed Valves)

- UL listed Shutoff Valves.
- FM Approved Oil Safety Shutoff Valves
- CSA Safety Valves

(Normally Open Valves)

- UL listed General Purpose Valves.
- CSA Electrically Operated Valves

Specifications (English units)

Pipe Size (ins.)	Orifice Size (ins.)	Cv Flow Factor	Minimum Operating Pressure Differential (psi)	Maximum Operating Pressure Differential (psi)		Max. Fluid Temp. °F	Catalog Number		Const. Ref.	Agency			Wattage
				#2 Fuel Oil at 60 SSU, #4 Fuel Oil @ 300 SSU	#5 or Heated #6 Oil up to 5000 SSU		FKM Seating	Stainless Steel Seating		UL	FM	CSA	
COMBUSTION (Fuel Oil) - Normally Closed without Bypass													
3/8	1/8	0.34	0	400	350	See Table Below	8266D001V	8266D001L	1	○	○	○	15.4/F
3/8	3/16	0.68	0	200	175		8266D007V	8266D007L	1	○	○	○	15.4/F
3/8	3/16	0.68	0	300	250		8266D011V	8266D011L	1	○	○	○	15.4/F
3/8	1/4	1.20	0	110	100		8266D023V	8266D023L	1	○	○	○	15.4/F
1/2	1/8	0.34	0	400	350		8266D047V	8266D047L	1	○	○	○	15.4/F
1/2	3/16	0.68	0	200	175		8266D053V	8266D053L	1	○	○	○	15.4/F
1/2	3/16	0.68	0	300	250		8266D057V	8266D057L	1	○	○	○	20/F
1/2	13/64	0.78	0	170	140		8266D061V	8266D061L	1	○	○	○	15.4/F
1/2	1/4	1.20	0	110	100		8266D069V	8266D069L	1	○	○	○	15.4/F
1/2	5/16	1.80	0	70	70		8266D077V	8266D077L	1	○	○	○	15.4/F
1/2	3/8	2.50	0	40	35		8266D085V	8266D085L	1	○	○	○	15.4/F
COMBUSTION (Fuel Oil) - Normally Closed with 1/2" NPT Bypass													
1/2	1/8	0.34	0	650	600	See Table Below	8266C203V	8266C203L	1	○	○	○	20/F
1/2	1/4	1.20	0	180	160		8266C215V	8266C215L	1	○	○	○	20/F
1/2	5/16	1.80	0	110	100		8266C219V	8266C219L	1	○	○	○	20/F
1/2	3/8	2.50	0	75	70		8266C223V	8266C223L	1	○	○	○	20/F
3/4	1/4	1.20	0	180	160		8266C239V	8266C239L	1	○	○	○	20/F
3/4	5/16	1.80	0	110	100		8266C243V	8266C243L	1	○	○	○	20/F
3/4	3/8	2.50	0	75	70		8266C247V	8266C247L	1	○	○	○	20/F
COMBUSTION (Fuel Oil) - Normally Open without Bypass													
3/8	1/8	0.34	0	425	400	See Table Below	8266D101V	8266D101L	1	○	-	○	15.4/F
3/8	3/16	0.68	0	160	150		8266D107V	8266D107L	1	○	-	○	15.4/F
3/8	1/4	1.20	0	90	75		8266D123V	8266D123L	1	○	-	○	15.4/F
1/2	3/16	0.68	0	160	150		8266D153V	8266D153L	1	○	-	○	15.4/F
1/2	13/64	0.78	0	130	125		8266D161V	8266D161L	1	○	-	○	15.4/F
1/2	1/4	1.20	0	90	75		8266D169V	8266D169L	1	○	-	○	15.4/F

○ = Safety Shutoff Valve.

Dimensions inches (mm)

COMBUSTION

Coil	Watt Rating	Class of Coil Insulation	Fluid Temp. °F	Ambient Temp. °F	Catalog No. Prefix
Standard	15.4	F	250	95	None Required
		F	225	104	
	20	F	225	77	
		F	200	95	
For Higher Fluid and/or Ambient Temp. Use	15.4	H	250	122	HT
	20	H	250	122	HB

Const. Ref. 1

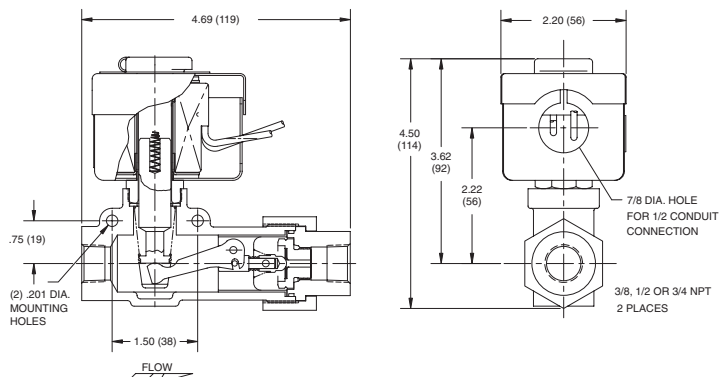

Must be mounted with solenoid vertical and upright.

Specifications (Metric units)

Pipe Size (ins.)	Orifice Size (mm)	Kv Flow (m³/hr)	Minimum Operating Pressure Differential (bar)	Maximum Operating Pressure Differential (bar)		Max. Fluid Temp. °C	Catalog Number		Const. Ref.	Agency			Wattage	
				#2 Fuel Oil at 60 SSU, #4 Fuel Oil @ 300 SSU	#5 or Heated #6 Oil up to 5000 SSU		FKM Seating	Stainless Steel Seating		UL	FM	CSA		
COMBUSTION (Fuel Oil) - Normally Closed without Bypass														
3/8	3	0.3	0	27.6	24.1	See Table Below	8266D001V	8266D001L	1	○	○	○	15.4/F	
3/8	5	0.6	0	13.8	12.1		8266D007V	8266D007L	1	○	○	○	15.4/F	
3/8	5	0.6	0	20.7	17.2		8266D011V	8266D011L	1	○	○	○	15.4/F	
3/8	6	1.0	0	7.6	6.9		8266D023V	8266D023L	1	○	○	○	15.4/F	
1/2	3	0.3	0	27.6	24.1		8266D047V	8266D047L	1	○	○	○	15.4/F	
1/2	5	0.6	0	13.8	12.1		8266D053V	8266D053L	1	○	○	○	15.4/F	
1/2	5	0.6	0	20.7	17.2		8266D057V	8266D057L	1	○	○	○	20/F	
1/2	5	0.7	0	11.7	9.7		8266D061V	8266D061L	1	○	○	○	15.4/F	
1/2	6	1.0	0	7.6	6.9		8266D069V	8266D069L	1	○	○	○	15.4/F	
1/2	8	1.5	0	4.8	4.8		8266D077V	8266D077L	1	○	○	○	15.4/F	
1/2	10	2.1	0	2.8	2.4		8266D085V	8266D085L	1	○	○	○	15.4/F	
COMBUSTION (Fuel Oil) - Normally Closed with 1/2" NPT Bypass														
1/2	3	0.3	0	44.8	41.4		See Table Below	8266C203V	8266C203L	1	○	○	○	20/F
1/2	6	1.0	0	12.4	11.0	8266C215V		8266C215L	1	○	○	○	20/F	
1/2	8	1.5	0	7.6	6.9	8266C219V		8266C219L	1	○	○	○	20/F	
1/2	10	2.1	0	5.2	4.8	8266C223V		8266C223L	1	○	○	○	20/F	
3/4	6	1.0	0	12.4	11.0	8266C239V		8266C239L	1	○	○	○	20/F	
3/4	8	1.5	0	7.6	6.9	8266C243V		8266C243L	1	○	○	○	20/F	
3/4	10	2.1	0	5.2	4.8	8266C247V		8266C247L	1	○	○	○	20/F	
COMBUSTION (Fuel Oil) - Normally Open without Bypass														
3/8	3	0.3	0	29.3	27.6	See Table Below	8266D101V	8266D101L	1	○	-	○	15.4/F	
3/8	5	0.6	0	11.0	10.3		8266D107V	8266D107L	1	○	-	○	15.4/F	
3/8	6	1.0	0	6.2	5.2		8266D123V	8266D123L	1	○	-	○	15.4/F	
1/2	5	0.6	0	11.0	10.3		8266D153V	8266D153L	1	○	-	○	15.4/F	
1/2	5	0.7	0	9.0	8.6		8266D161V	8266D161L	1	○	-	○	15.4/F	
1/2	6	1.0	0	6.2	5.2		8266D169V	8266D169L	1	○	-	○	15.4/F	

○ = Safety Shutoff Valve.

Coil	Watt Rating	Class of Coil Insulation	Fluid Temp. °F (°C)	Ambient Temp. °F (°C)	Catalog No. Prefix
Standard	15.4	F	250 (121)	95 (35)	None Required
		F	225 (107)	104 (40)	
	20	F	225 (107)	77 (25)	
F		200 (93)	95 (35)		
F		180 (82)	104 (40)		
For Higher Fluid and/or Ambient Temp. Use	15.4	H	250 (121)	122 (50)	HT
	20	H	250 (121)	122 (50)	HB

