

CUE

Safety instructions and other important information



CUE
Installation and operating instructions
<http://net.grundfos.com/qri/96780034>



CUE
Quick guide
<http://net.grundfos.com/qri/96794343>

CUE

English (GB)

Safety instructions.	4
Appendix A.	12
China RoHS	24
Declaration of conformity	25
Declaration of conformity	28
Operating manual EAC	29

English (GB) Safety instructions

Original safety instructions

These safety instructions give a quick overview of the safety precautions to be taken in connection with any work on this product. Observe these safety instructions during handling, installation, operation, maintenance, service and repair of this product. These safety instructions are a supplementary document, and all safety instructions will appear again in the relevant sections of the installation and operating instructions. Keep these safety instructions at the installation site for future reference.

General information



Read this document and the online version of the installation and operating instructions before you install the product. Installation and operation must comply with local regulations and accepted codes of good practice.

Hazard statements

The symbols and hazard statements below may appear in Grundfos installation and operating instructions, safety instructions and service instructions.



DANGER

Indicates a hazardous situation which, if not avoided, will result in death or serious personal injury.



WARNING

Indicates a hazardous situation which, if not avoided, could result in death or serious personal injury.



CAUTION

Indicates a hazardous situation which, if not avoided, could result in minor or moderate personal injury.

The hazard statements are structured in the following way:



SIGNAL WORD

Description of the hazard

Consequence of ignoring the warning

- Action to avoid the hazard.

Notes

The symbols and notes below may appear in Grundfos installation and operating instructions, safety instructions and service instructions.



Observe these instructions for explosion-proof products.



A blue or grey circle with a white graphical symbol indicates that an action must be taken.



A red or grey circle with a diagonal bar, possibly with a black graphical symbol, indicates that an action must not be taken or must be stopped.



If these instructions are not observed, it may result in malfunction or damage to the equipment.



Tips and advice that make the work easier.

Intended use

The CUE frequency converters can be used in both new and existing installations. Local operation is performed via the operating panel that has a graphic display showing the menu structure. The menu structure uses the same system as the Grundfos E-pumps.

Remote operation is performed via external signals, for instance, via digital inputs or GENibus communication.



Do not use the CUE to control ATEX-approved motors and do not use it in applications with a potential of explosion risk.

Receiving the product



WARNING

Crushing of feet

Death or serious personal injury

- Use safety shoes during transportation and avoid stacking boxes.



CAUTION

Lifting hazard

Minor or moderate personal injury

- Use proper lifting equipment when handling the product.
- Follow local regulations.

Inspecting the product

Check on receipt that the packaging is intact and the unit is complete. In case of damage, contact the carrier immediately.



The CUE is delivered in packaging that is not suitable for outdoor storage.

0.55-90 kW / 0.75-125 hp: A2-A5, B1-B4, C1-C4

To determine a safe lifting method, check the weight of the unit. See the chapter on dimensions and weights.

Ensure that the lifting device is suitable for the task. If necessary, use a hoist, crane, or forklift with the appropriate rating to move the unit.

Make sure to use the hoist rings on the unit, if provided.

110-315 kW / 150-450 hp: D1h-D7h

WARNING

Overhead load

Death or serious personal injury

- Use lifting equipment rated for the weight of the product, and follow local regulations when lifting the product.
- Never walk under suspended loads.
- Wear suitable personal protective equipment.
- Make sure that the angle from the top of the drive module to the lifting cables is at least 65°, as the angle affects the maximum load force exerted on the cable.
- Observe the center of gravity and position the load correctly to avoid unexpected shifting during lifting and transport.



Always lift the drive using the dedicated eye bolts at the top of the drive.

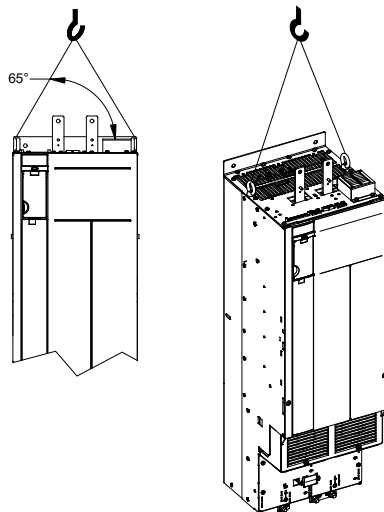

TM089651

355-560 kW / 500-750 hp: E1h-E2h

WARNING

Overhead load

Death or serious personal injury

- Use lifting equipment rated for the weight of the product, and follow local regulations when lifting the product.
- Never walk under suspended loads.
- Wear suitable personal protective equipment.
- Make sure that the angle from the top of the drive module to the lifting cables is at least 60°, as the angle affects the maximum load force exerted on the cable.
- Observe the center of gravity and position the load correctly to avoid unexpected shifting during lifting and transport.



Always lift the drive using a lifting bar inserted into the lifting eyes.

The maximum diameter for the lifting bar must be 20 mm (0.8 inch).

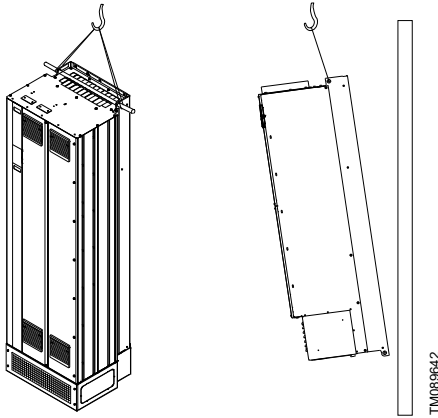

Installation requirements

WARNING Sharp element



Death or serious personal injury

- Use safety knives and protective gloves when unpacking the product.

WARNING Lifting hazard



Death or serious personal injury

- Use proper lifting equipment when handling the product.
- Follow local regulations.

WARNING Electric shock

Death or serious personal injury



- Before starting any work on the product, make sure that the power supply is switched off, and that it cannot be switched on accidentally. Follow the minimum waiting time after powering off, as described in the table below.

- Touching the electrical parts may be fatal, even after the CUE is switched off.



Any installation, maintenance and inspection must be carried out by trained personnel.

Safety regulations

- The **OFF** button of the operating panel does not disconnect the CUE from the power supply, and therefore must not be used as a safety switch.

- The CUE must be earthed correctly and protected against indirect contact, according to local regulations.
- The leakage current to protective earth exceeds 3.5 mA.
- Enclosures with an IP20/21 rating must be equipped with an access panel to prevent free access to the unit.
- Enclosures with an IP54/55 rating must not be installed outdoors without additional protection against weather conditions and UV radiation.
- The STO function does not disconnect the CUE from the power supply, and therefore must not be used as a safety switch.
- The STO function does not prevent unwanted movement from external forces on the motor, such as back pressure.
- A protective cover must be installed on the motor shaft.

Always observe local regulations concerning cable cross-section, short-circuit protection and overcurrent protection.

The general safety necessitates special considerations as to the following aspects:

- fuses and switches for overcurrent and short-circuit protection
- selection of cables (mains current, motor, load distribution and relay)
- net configuration (IT, TN, earthing)
- safety regarding connecting inputs and outputs (PELV).

IT mains

If the drive is supplied from an isolated mains source, for instance, IT mains, floating delta or grounded delta, or a TT/TN-S system with a grounded leg, it is recommended to turn off the RFI switch via the parameter **14-50 RFI Filter** on the drive, and the parameter **14-50 RFI Filter** on the filter itself, as described in the standard IEC 364-3. In the Off position, the filter capacitors between the chassis and the DC link are cut off to avoid damage to the DC link and reduce the ground capacity currents, according to the IEC 61800-3.

In the following cases, it is recommended to set the parameter **14-50 RFI Filter** to **[1] On**:

- optimum EMC performance is required
- multimotor setup
- the motor cable length is above 25 m (82 ft).



Do not connect 380-500 V CUE frequency converters to mains supplies with a voltage between phase and protective earth of more than 440 V.



It is not recommended to use output contactors for 525-690 V drives connected to an IT mains network.



It is important to use isolation monitors that are rated for use with power electronics, in accordance with the IEC 61557-8.

Environmental restrictions

Aggressive environments



Do not install the CUE in an environment where the air contains liquids, particles or gases that may affect and damage the electronic components.

The unit contains a large number of mechanical and electronic components, that are all vulnerable to environmental impact.

Performance reduction

Low air pressure



At altitudes above 2000 m (6600 ft), the PELV requirements cannot be met.

At low air pressure, the cooling capacity of air is reduced, and the CUE automatically reduces the performance to prevent overload. It may be necessary to select a unit with higher performance.

Long motor cables

The maximum allowed cable length is 300 m (1000 ft) for unscreened and 150 m (500 ft) for screened cables. In case longer cables are needed, contact Grundfos.

Mounting the product

WARNING

Crushing of feet

Death or serious personal injury

- The CUE is very heavy and may fall over if the pedestal is not anchored to the floor.



The user is responsible for mounting the CUE securely on a firm surface.

Electrical connection

WARNING

Electric shock

Death or serious personal injury



- Before starting any work on the product, make sure that the power supply is switched off and that it cannot be accidentally switched on. For required waiting times after powering off, see the section on installation requirements.
- Touching the electrical parts may be fatal, even after the CUE is switched off.

The owner or installer is responsible for ensuring correct earthing and protection according to local regulations, along with proper security measures.



For products equipped with the Safe Torque Off (STO) function, ensure short-circuit protection of the cable between terminal 37 and the external safety device.

The frequency converter parameters can be password protected.

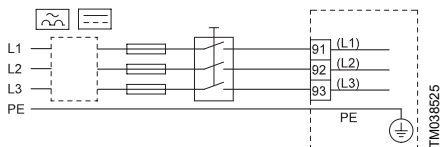

Example of three-phase mains connection of CUE with main switch, backup fuses and additional protection

Protection against electric shock, indirect contact

CAUTION

Electric shock

Minor or moderate personal injury



- The CUE must be earthed correctly and protected against indirect contact according to local regulations.
- If the leakage current is greater than 3.5 mA, use a PE cable with a minimum cross-section of at least 10 mm² (7 AWG), or use 2 separate PE cables with the same cross section as the power cable.

The leakage currents are measured in accordance with the EN 61800-5-1:2007.

Protective conductors must always have a yellow and green (PE) or yellow, green and blue (PEN) colour marking.

A permanent installation and mains connection is required for the CUE.

Short-circuit current

The CUE and the supply system must be protected against short-circuit currents.

Grundfos requires that the specified backup fuses are used for protection against short-circuit currents. See the section on cable cross-sections regarding signal terminals.

The unit offers complete short-circuit protection in case of a short-circuit occurs on the motor output.

Additional protection



WARNING Electric shock

Death or serious personal injury

- The leakage current to protective earth must exceed 3.5 mA.

If the CUE is connected to an electrical installation where an earth leakage circuit breaker/residual-current device (ELCB/RCD) is used as additional protection, the ELCB/RCD must be a Type B, marked with the following symbols:

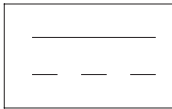
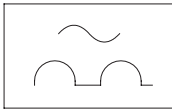

TWA06789

TM006789

The total leakage current of all the electrical equipment in the installation must be taken into account.

For the leakage current of the CUE during normal operation, see the section on electrical data.

During startup and in asymmetrical supply systems, the leakage current can be higher than normal and may cause the ELCB/RCD to trip.

Motor protection

The motor requires no external motor protection as the CUE protects it against thermal overloading and blocking.

Protection against overcurrent

The CUE has internal overcurrent protection to provide overload protection on the motor output side.

EMC-compliant installation



A screened motor cable must be used for the CUE to meet the EMC requirements.

Cable requirements



Always comply with local regulations on cable cross-sections.

Cable type	Max. length	
	[m]	[ft]
Screened motor cable	150	500
Unscreened motor cable	300	1000
Signal cable	300	1000

Motor and mains connection



Confirm that the mains voltage and frequency correspond to the values on the nameplate of the CUE and the motor.



A screened motor cable is required for the CUE to meet the EMC requirements.

Motor and mains connection

Three-phase mains connection

The cables in the terminal box must be as short as possible. However, the separated protective earth conductor must be so long that it is the last one to be disconnected in case the cable is inadvertently pulled out of the cable entry.

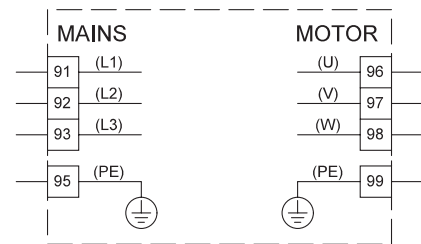

TM038799

Wiring diagram, three-phase mains connection

Terminal	Function
91	(L1)
92	(L2) Three-phase mains supply
93	(L3)
95/99	(PE) Protective earth connection
96	(U)
97	(V) Three-phase motor connection, 0-100 % of mains voltage
98	(W)

Connection overview



Refer to the appendix for connection illustrations.

Enclosure	Tightening torque [Nm]		
	Motor/ Mains	Protective earth	Relay
A2, A3, A4, A5	1.8	3	0.6
B1, B3	1.8	3	0.6
B2, B4	4.5	3	0.6
C1, C3	10	3	0.6
C2, C4	14/24 ⁴⁾	3	0.6

⁴⁾ $\varnothing \leq 95 \text{ mm}^2 / \varnothing \geq 95 \text{ mm}^2$

Enclosure	Thread size				Relay
	Mains/Motor		Earth		
	M10	M12	M8	M10	
Torque [Nm]					
D1h- D7h	19	37	9.6	19.1	0.5
E1h, E2h	19	37	9.6	19.1	0.5

Motor connection

1. Connect the earth conductor to terminal 99 (PE).
2. Connect the motor conductors to terminals 96 (U), 97 (V), 98 (W) of the motor plug.
3. Fix the screened cable with a cable clamp.

Mains connection

1. Connect the earth conductor to terminal 95 (PE).
2. Connect the mains conductors to terminals 91 (L1), 92 (L2), 93 (L3).
3. Fix the mains cable with a cable clamp.

Connecting the signal terminals



Signal cables must be separated from other cable groups by reinforced insulation in their entire lengths.

Connect the signal cables according to the guidelines for good practice to ensure an EMC-compliant installation.

- Use screened signal cables with a cable cross-section of 0.5 - 1.5 mm² (20 - 14 AWG).
- Use a screened 3-core bus cable in new systems.

Connecting a thermistor (PTC) to the CUE

A PELV circuit provides protection against electric shock. Special connection requirements apply to this type of circuit, as described in the EN 61800-5-1.

To maintain the PELV range, all connections made to the control terminals must be of the PELV range, for example, the thermistor must have reinforced or double insulation.

MCB 114 sensor input module



When using a Pt100 sensor with a 3-wire cable, the resistance must not exceed 30 Ω .

STO installation

DANGER

Exposure to high pressure or toxic liquids

Death or serious personal injury

- Make sure to remove the jumper. Doing otherwise disables the STO function and the motor might not stop as intended.
- Make sure to use a safety-monitoring relay compliant with the Category 3/ PL d (ISO 13849-1) or the SIL 2 (EN 62061, IEC 61508).
- Perform a functional test every 12 months to ensure that the system works properly.



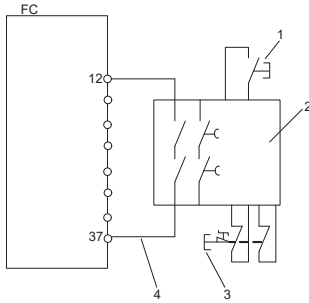

STO wiring

TM074594

Pos.	Description
1	Reset button
2	Safety relay, category 3, PL d or SIL2
3	Emergency stop button
4	Short-circuit protected cable, if the product is not installed inside an IP54 cabinet

Servicing the product

CAUTION

Electric shock

Minor or moderate personal injury

- Before starting any work on the product, make sure that the power supply is switched off and that it cannot be accidentally switched on. Follow the minimum waiting time after powering off as described in the section on installation requirements.
- Touching the electrical parts may be fatal, even after the CUE is switched off.



Conduct a functional test every 12 months to detect any failure or malfunction of the STO functionality.

To conduct the functional test, perform the following steps:

1. Remove the 24 V DC voltage supply from the terminal 37.
2. Check if the operating panel displays the alarm **Safe Stop A68**.
3. Verify that the frequency converter trips the unit.
4. Verify that the motor coasts to a complete stop.
5. Verify that the motor cannot be started.
6. Reconnect the 24 V DC voltage supply to the terminal 37.

7. Verify that the motor is not started automatically and restarts only by receiving a reset signal, either via the bus, the digital I/O or the **RESET** button.

Operating conditions

Humidity

Description	Percentage [%]
Relative humidity	5-95

Ambient temperature

Description	0.55-90 kW / 0.75-125 hp	110-560 kW / 150-750 hp
	Temperature	
	[°C] / [°F]	[°C] / [°F]
Ambient temperature	Max. 50 / 122	Max. 45 / 113
• with derating	Max. 55 / 131	Max. 55 / 131
Minimum ambient temperature	0 / 32	0 / 32
• at full operation		
• at reduced operation	-10 / 14	-10 / 14
Temperature during storage and transport	-25 to +65 / -13 to +149	-25 to +65 / -13 to +149

Installation altitude

Maximum altitude above sea level	[m]	[ft]
Without performance reduction	1000	3280
With performance reduction	3000	9840

Inputs and outputs

Mains supply



Do not use the power supply for switching the CUE on and off.

Terminals: L1, L2, L3.

Supply voltage:

- 200-240 V \pm 10 %
- 380-500 V \pm 10 %
- 525-600 V \pm 10 %

- 525-690 V \pm 10 %.

Supply frequency: 50/60 Hz.

Maximum temporary imbalance between phases: 3 % of the rated value.

Leakage current to protective earth: > 3.5 mA.

Number of cut-ins, enclosure A: maximum 2 times/min.

Number of cut-ins, enclosures B and C: maximum 1 time/min.

Disposing of the product



The crossed-out wheeled bin symbol on a product means that it must be disposed of separately from household waste. When a product marked with this symbol reaches its end of life, take it to a collection point designated by the local waste disposal authorities.

The separate collection and recycling of such products will help protect the environment and human health.

Appendix A

A.1. Safety note

The recommended fuses are suitable for use on a circuit capable of delivering not more than 100000 rms symmetrical amperes, depending on the voltage rating of the drive. With the proper fuses, the short-circuit current rating (SCCR) of the drive is 100000 rms symmetrical amperes.

A.2. Recommended CE fuses and circuit breakers

Enclosures A, B and C

200-240 V

Enclosure	Power		Fuse size	Max. fuse size	Circuit breaker Moeller	Max. trip level [A]
	[kW]	[hp]				
A2	0.75	1	gG-10	gG-32	PKZM0-25	25
	1.1	1.5	gG-10			
	1.5	2	gG-10			
	2.2	3	gG-16			
A3	3	4	gG-16	gG-32	PKZM0-25	25
	3.7	5	gG-20			
A4	0.75	1	gG-10	gG-32	PKZM0-25	25
	1.1	1.5	gG-10			
	1.5	2	gG-10			
	2.2	3	gG-16			
A5	0.75	1	gG-10	gG-32	PKZM0-25	25
	1.1	1.5	gG-10			
	1.5	2	gG-10			
	2.2	3	gG-16			
	3	4	gG-16			
	3.7	5	gG-20			
B1	5.5	7.5	gG-25	gG-80	PKZM4-63	63
	7.5	10	gG-32			
	11	15	gG-32			
B2	15	20	gG-50	gG-100	NZMB1-A100	100
B3	5.5	7.5	gG-25	gG-63	PKZM4-50	50
	7.5	10	gG-25			
	11	15	gG-32			
B4	15	20	gG-50	gG-125	NZMB1-A100	100
	18	25	gG-63			

Enclosure	Power		Fuse size	Max. fuse size	Circuit breaker Moeller	Max. trip level [A]
	[kW]	[hp]				
C1	18	25	gG-63	gG-160	NZMB2-A200	160
	22	30	gG-80			
	30	40	gG-100	aR-160		
C2	37	50	aR-160	aR-200	NZMB2-A250	250
	45	60	aR-200	aR-250		
C3	22	30	gG-80	gG-150	NZMB2-A200	150
	30	40	aR-125	aR-160		
C4	27	50	aR-160	aR-200	NZMB2-A250	250
	45	60	aR-200	aR-250		

3 × 380-500 V

Enclosure	Power		Fuse size	Max. fuse size	Circuit breaker Moeller	Max. trip level [A]
	[kW]	[hp]				
A2	1.1	1.5	gG-10	gG-25	PKZM0-25	25
	1.5	2	gG-10			
	2.2	3	gG-10			
	3	4	gG-10			
	4	5	gG-16			
A3	5.5	7.5	gG-16	gG-32	PKZM0-25	25
	7.5	10	gG-16			
A4	1.1	1.5	gG-10	gG-32	PKZM0-25	25
	1.5	2	gG-10			
	2.2	3	gG-10			
	3	4	gG-10			
	4	5	gG-16			
A5	1.1	1.5	gG-10	gG-32	PKZM0-25	25
	1.5	2	gG-10			
	2.2	3	gG-10			
	3	4	gG-10			
	4	5	gG-16			
	5.5	7.5	gG-16			
B1	7.5	10	gG-16	gG-80	PKZM4-63	63
	11	15	gG-40			
	15	20	gG-40			
B2	18	25	gG-40	gG-100	NZMB1-A100	100
	22	30	gG-50			
	30	40	gG-63			

Enclosure	Power		Fuse size	Max. fuse size	Circuit breaker Moeller	Max. trip level [A]
	[kW]	[hp]				
B3	11	15	gG-40	gG-63	PKZM4-50	50
	15	20	gG-40			
	18	25	gG-40			
B4	22	30	gG-50	gG-125	NZMB1-A100	100
	30	40	gG-63			
	37	50	gG-80			
	37	50	gG-80			
C1	45	60	gG-100	gG-160	NZMB2-A200	160
	55	75	gG-160			
C2	75	100	aR-200	aR-250	NZMB2-A250	250
	90	125	aR-250			
C3	45	60	gG-100	gG-150	NZMB2-A200	150
	55	75	gG-160	gG-160		
C4	75	100	aR-200	aR-250	NZMB2-A250	250
	90	125	aR-250			

3 × 525-600 V

Enclosure	Power		Fuse size	Max. fuse size	Circuit breaker Moeller	Max. trip level [A]
	[kW]	[hp]				
A2	1.1	1.5	gG-10	gG-25	PKZM0-25	25
	1.5	2	gG-10			
	2.2	3	gG-10			
	3	4	gG-10			
	4	5	gG-10			
A3	5.5	7.5	gG-10	gG-32	PKZM0-25	25
	7.5	10	gG-16			
A5	1.1	1.5	gG-10	gG-32	PKZM0-25	25
	1.5	2	gG-10			
	2.2	3	gG-10			
	3	4	gG-10			
	4	5	gG-10			
	5.5	7.5	gG-10			
	7.5	10	gG-16			
B1	11	15	gG-25	gG-80	PKZM4-63	63
	15	20	gG-32			
	18.5	25	gG-40			

Enclosure	Power		Fuse size	Max. fuse size	Circuit breaker Moeller	Max. trip level [A]
	[kW]	[hp]				
B2	22	30	gG-50	gG-100	NZMB1-A100	100
	30	40	gG-63			
B3	11	15	gG-25	gG-63	PKZM4-50	50
	15	20	gG-32			
	18	25	gG-32			
B4	22	30	gG-40	gG-125	NZMB1-A100	100
	30	40	gG-50			
	37	50	gG-63			
C1	37	50	gG-63	gG-160	NZMB2-A200	160
	45	60	gG-100	-		
	55	60	aR-160	aR-250		
C2	75	100	aR-200	aR-250	NZMB2-A250	250
	90	125	aR-200			
C3	45	60	gG-63	gG-150	NZMB2-A200	150
	55	75	gG-100			
C4	75	100	aR-160	aR-250	NZMB2-A250	250
	90	125	aR-200			

3 × 525-690 V

Enclosure	Power		Fuse size	Max. fuse size	Circuit breaker Moeller	Max. trip level [A]
	[kW]	[hp]				
A3	1.1	1.5	gG-6	gG-25	PKZM0-16	16
	1.5	2	gG-6			
	2.2	3	gG-6			
	3	4	gG-10			
	4	5	gG-10			
	5.5	7.5	gG-16			
	7.5	10	gG-16			
B2	11	15	gG-25	gG-63	-	-
	15	20	gG-25			
	18	24	gG-32			
	22	30	gG-32			

Enclosure	Power		Fuse size	Max. fuse size	Circuit breaker Moeller	Max. trip level [A]
	[kW]	[hp]				
C2	30	40	gG-40	gG-80	-	-
	37	50	gG-63	gG-100		
	45	60	gG-63	gG-125		
	55	75	gG-80	gG-160		
	75	100	gG-100			
C3	37	50	gG-100	gG-125	-	-
	45	60	gG-125	gG-160		

Enclosures D1h-D7h

3 × 380-500 V

Power		Recommended fuse size
[kW]	[hp]	
110	150	aR-315
132	200	aR-350
160	250	aR-400
200	300	aR-500
250	350	aR-630
315	450	aR-800

3 × 525-690 V

Power		Recommended fuse size
[kW]	[hp]	
110	150	aR-315
132	200	aR-315
160	250	aR-315
200	300	aR-550
250	350	aR-550
315	450	aR-550

Space heater fuse recommendation

Rating		Bussmann
Current [A]	Supply voltage [V]	
2.5	600	LPJ-21/2SP

Enclosures E1h and E2h

380-500 and 525-690 V

Supply voltage [V]	Bussmann
380-500	170M7309

Supply voltage [V]	Bussmann
525-690	170M7342

Space heater fuse recommendation

Rating		Bussmann
Current [A]	Supply voltage [V]	
2.5	600	LPJ-21/2SP

A.3. Recommended UL fuses

Enclosures A, B and C

1 × 200-240 V

Power		Max. pre-fuse size [A]	Bussmann							
[kW]	[hp]		JFHR2	RK1	Type J	Type T	Type CC	Type CC	Type CC	
1.1	1.5	15	FWX-15	KTN-15	JKS-15	JJN-15	FNQ-R-15	KTK-R-15	LP-CC-15	
1.5	2.0	20	FWX-20	KTN-20	JKS-20	JJN-20	FNQ-R-20	KTK-R-20	LP-CC-20	
2.2	3.0	30	FWX-30	KTN-30	JKS-30	JJN-30	FNQ-R-30	KTK-R-30	LP-CC-30	
3.0	4.0	35	FWX-35	KTN-35	JKS-35	JJN-35	-	-	-	
3.7	5.0	50	FWX-50	KTN-50	JKS-50	JJN-50	-	-	-	
5.5	7.5	60	FWX-60	KTN-60	JKS-60	JJN-60	-	-	-	
7.5	10	80	FWX-80	KTN-80	JKS-80	JJN-80	-	-	-	
15	20	150	FWX-150	KTN-150	JKS-150	JJN-150	-	-	-	
22	30	200	FWX-200	KTN-200	JKS-200	JJN-200	-	-	-	

Power		Max. pre-fuse size [A]	SIBA	Littelfuse	Ferraz Shawmut		
[kW]	[hp]		Type RK1	Type RK1	Type CC	Type RK1	Type J
1.1	1.5	15	5017906-016	KLN-R15	ATM-R15	A2K-15R	HSJ15
1.5	2.0	20	5017906-020	KLN-R20	ATM-R20	A2K-20R	HSJ20
2.2	3.0	30	5017906-032	KLN-R30	ATM-R30	A2K-30R	HSJ30
3.0	4.0	35	-	KLN-R35	-	A2K-35R	HSJ35
3.7	5.0	50	5017906-050	KLN-R50	-	A2K-50R	HSJ50
5.5	7.5	60	5017906-063	KLN-R60	-	A2K-60R	HSJ60
7.5	10	80	5017906-080	KLN-R80	-	A2K-80R	HSJ80
15	20	150	5017906-150	KLN-R150	-	A2K-150R	HSJ150
22	30	200	5017906-200	KLN-R200	-	A2K-200R	HSJ200

3 × 200-240 V

Power		Bussmann						
[kW]	[hp]	JFHR2	RK1	Type J	Type T	Type CC	Type CC	Type CC
0.55	0.75	FWX-10	KTN-R10	JKS-10	JJN-10	FNQ-R-10	KTK-R-10	LP-CC-10
0.75	1.0	FWX-10	KTN-R10	JKS-10	JJN-10	FNQ-R-10	KTK-R-10	LP-CC-10
1.1	1.5	FWX-10	KTN-R10	JKS-10	JJN-10	FNQ-R-10	KTK-R-10	LP-CC-10
1.5	2.0	FWX-15	KTN-R15	JKS-15	JJN-15	FNQ-R-15	KTK-R-15	LP-CC-15
2.2	3.0	FWX-20	KTN-R20	JKS-20	JJN-20	FNQ-R-20	KTK-R-20	LP-CC-20
3.0	4.0	FWX-25	KTN-R25	JKS-25	JJN-25	FNQ-R-25	KTK-R-25	LP-CC-25
3.7	4.0	FWX-30	KTN-R30	JKS-30	JJN-30	FNQ-R-30	KTK-R-30	LP-CC-30
5.5	7.5	FWX-50	KTN-R50	JKS-50	JJN-50	-	-	-
7.5	10	FWX-50	KTN-R50	JKS-50	JJN-50	-	-	-
11	15	FWX-60	KTN-R60	JKS-60	JJN-60	-	-	-
15	20	FWX-80	KTN-R80	JKS-80	JJN-80	-	-	-
18	25	FWX-125	KTN-R125	JKS-125	JJN-125	-	-	-
22	30	FWX-125	KTN-R125	JKS-125	JJN-125	-	-	-
30	40	FWX-150	KTN-R150	JKS-150	JJN-150	-	-	-
37	50	FWX-200	KTN-R200	JKS-200	JJN-200	-	-	-
45	60	FWX-250	KTN-R250	JKS-250	JJN-250	-	-	-

Power		SIBA	Littelfuse		Ferraz Shawmut			
[kW]	[hp]	Type RK1	Type RK1	JFHR2	Type CC	Type RK1	JFHR2	Type J
0.55	0.75	5017906-010	KLN-R-10	-	ATM-R-10	A2K-10-R	-	HSJ-10
0.75	1.0	5017906-010	KLN-R-10	-	ATM-R-10	A2K-10-R	-	HSJ-10
1.1	1.5	5017906-010	KLN-R-10	-	ATM-R-10	A2K-10-R	-	HSJ-10
1.5	2.0	5017906-016	KLN-R-15	-	ATM-R-15	A2K-15-R	-	HSJ-15
2.2	3.0	5017906-020	KLN-R-20	-	ATM-R-20	A2K-20-R	-	HSJ-20
3.0	4.0	5017906-025	KLN-R-25	-	ATM-R-25	A2K-25-R	-	HSJ-25
3.7	4.0	5012406-032	KLN-R-30	-	ATM-R-30	A2K-30-R	-	HSJ-30
5.5	7.5	5014006-050	KLN-R-50	-	-	A2K-50-R	-	HSJ-50
7.5	10	5014006-050	KLN-R-50	-	-	A2K-50-R	-	HSJ-50
11	15	5014006-063	KLN-R-60	-	-	A2K-60-R	-	HSJ-60
15	20	5014006-080	KLN-R-80	-	-	A2K-80-R	-	HSJ-80
18	25	5017906-125	KLN-R-125	-	-	A2K-125-R	-	HSJ-125
22	30	2028220-125	KLN-R-125	-	-	A2K-125-R	-	HSJ-125
30	40	2028220-150	KLN-R-150	L25S-150	-	A2K-150-R	A25X-150	HSJ-150
37	50	2028220-200	KLN-R-200	L25S-200	-	A2K-200-R	A25X-200	HSJ-200
45	60	2028220-250	KLN-R-250	L25S-250	-	A2K-250-R	A25X-250	HSJ-250

3 × 380-500 V

Power		Bussmann						
[kW]	[hp]	JFHR2	RK1	Type J	Type T	Type CC	Type CC	Type CC
-	-	FWH-6	KTS-R-6	JKS-6	JJS-6	FNQ-R-6	KTK-R-5	LP-CC-6
1.1	1.5	FWH-10	KTS-R-10	JKS-10	JJS-10	FNQ-R-10	KTK-R-10	LP-CC-10
1.5	2.0	FWH-10	KTS-R-10	JKS-10	JJS-10	FNQ-R-10	KTK-R-10	LP-CC-10
2.2	3.0	FWH-10	KTS-R-10	JKS-10	JJS-10	FNQ-R-10	KTK-R-10	LP-CC-10
3.0	4.0	FWH-15	KTS-R-15	JKS-15	JJS-15	FNQ-R-15	KTK-R-15	LP-CC-15
4.0	5.0	FWH-20	KTS-R-20	JKS-20	JJS-20	FNQ-R-20	KTK-R-20	LP-CC-20
5.5	7.5	FWH-25	KTS-R-25	JKS-25	JJS-25	FNQ-R-25	KTK-R-25	LP-CC-25
7.5	10	FWH-30	KTS-R-30	JKS-30	JJS-30	FNQ-R-30	KTK-R-30	LP-CC-30
11	15	FWH-40	KTS-R-40	JKS-40	JJS-40	-	-	-
15	20	FWH-50	KTS-R-50	JKS-50	JJS-50	-	-	-
22	30	FWH-60	KTS-R-60	JKS-60	JJS-60	-	-	-
30	40	FWH-80	KTS-R-80	JKS-80	JJS-80	-	-	-
37	50	FWH-100	KTS-R-100	JKS-100	JJS-100	-	-	-
45	60	FWH-125	KTS-R-125	JKS-125	JJS-125	-	-	-
55	75	FWH-150	KTS-R-150	JKS-150	JJS-150	-	-	-
75	100	FWH-200	KTS-R-200	JKS-200	JJS-150	-	-	-
90	125	FWH-250	KTS-R-250	JKS-250	JJS-250	-	-	-

Power		SIBA	Littelfuse		Ferraz Shawmut			
[kW]	[hp]	Type RK1	Type RK1	JFHR2	Type CC	Type RK1	JFHR2	Type J
-	-	5017906-006	KLS-R-6	-	ATM-R-6	A6K-6-R	-	HSJ-6
1.1	1.5	5017906-010	KLN-R-10	-	ATM-R-10	A6K-10-R	-	HSJ-10
1.5	2.0	5017906-010	KLN-R-10	-	ATM-R-10	A6K-10-R	-	HSJ-10
2.2	3.0	5017906-010	KLN-R-10	-	ATM-R-10	A6K-10-R	-	HSJ-10
3.0	4.0	5017906-016	KLN-R-15	-	ATM-R-15	A6K-15-R	-	HSJ-15
4.0	5.0	5017906-020	KLN-R-20	-	ATM-R-20	A6K-20-R	-	HSJ-20
5.5	7.5	5017906-025	KLN-R-25	-	ATM-R-25	A6K-25-R	-	HSJ-25
7.5	10	5012406-032	KLN-R-30	-	ATM-R-30	A6K-30-R	-	HSJ-30
11	15	5014006-040	KLS-R-40	-	-	A6K-40-R	-	HSJ-40
15	20	5014006-050	KLN-R-50	-	-	A6K-50-R	-	HSJ-50
22	30	5014006-063	KLN-R-60	-	-	A6K-60-R	-	HSJ-60
30	40	2028220-120	KLN-R-80	-	-	A6K-80-R	-	HSJ-80
37	50	2028220-125	KLN-R-100	-	-	A6K-100-R	-	HSJ-100
45	60	2028220-125	KLN-R-125	-	-	A6K-125-R	-	HSJ-125
55	75	2028220-160	KLN-R-150	-	-	A6K-150-R	-	HSJ-150
75	100	2028220-200	KLN-R-200	L50-S-225	-	A6K-200-R	A50-P-225	HSJ-200
90	125	2028220-250	KLN-R-250	L50-S-250	-	A6K-250-R	A50-P-250	HSJ-250

525-600 V

Power		Bussmann					
[kW]	[hp]	Type RK1	Type J	Type T	Type CC	Type CC	Type CC
0.75	1.5	KTS-R-5	JKS-5	JJS-6	FNQ-R-5	KTK-R-5	LP-CC-5
1.1	1.5	KTS-R-5	JKS-5	JJS-6	FNQ-R-5	KTK-R-5	LP-CC-5
1.5	2.0	KTS-R-10	JKS-10	JJS-10	FNQ-R-10	KTK-R-10	LP-CC-10
2.2	3.0	KTS-R-10	JKS-10	JJS-10	FNQ-R-10	KTK-R-10	LP-CC-10
3.0	4.0	KTS-R-15	JKS-15	JJS-15	FNQ-R-15	KTK-R-15	LP-CC-15
4.0	5.0	KTS-R-20	JKS-20	JJS-20	FNQ-R-20	KTK-R-20	LP-CC-20
5.5	7.5	KTS-R-25	JKS-25	JJS-25	FNQ-R-25	KTK-R-25	LP-CC-25
7.5	10	KTS-R-30	JKS-30	JJS-30	FNQ-R-30	KTK-R-30	LP-CC-30
11	15	KTS-R-35	JKS-35	JJS-35	-	-	-
15	20	KTS-R-35	JKS-35	JJS-35	-	-	-
18	24	KTS-R-45	JKS-45	JJS-45	-	-	-
22	30	KTS-R-50	JKS-50	JJS-50	-	-	-
30	40	KTS-R-60	JKS-60	JJS-60	-	-	-
37	50	KTS-R-80	JKS-80	JJS-80	-	-	-
45	60	KTS-R-100	JKS-100	JJS-100	-	-	-
55	75	KTS-R-125	JKS-125	JJS-125	-	-	-
75	100	KTS-R-150	JKS-150	JJS-150	-	-	-
90	125	KTS-R-175	JKS-175	JJS-175	-	-	-

Power		SIBA	Littelfuse	Ferraz Shawmut	
[kW]	[hp]	Type RK1	Type RK1	Type RK1	Type J
0.75	1.5	5017906-005	KLS-R-005	A6K-5-R	HSJ-6
1.1	1.5	5017906-005	KLS-R-005	A6K-5-R	HSJ-6
1.5	2.0	5017906-010	KLS-R-010	A6K-10-R	HSJ-10
2.2	3.0	5017906-010	KLS-R-010	A6K-10-R	HSJ-10
3.0	4.0	5017906-016	KLS-R-015	A6K-15-R	HSJ-15
4.0	5.0	5017906-020	KLS-R-020	A6K-20-R	HSJ-20
5.5	7.5	5017906-025	KLS-R-025	A6K-25-R	HSJ-25
7.5	10	5017906-030	KLS-R-030	A6K-30-R	HSJ-30
11	15	5014006-040	KLS-R-035	A6K-35-R	HSJ-35
15	20	5014006-040	KLS-R-035	A6K-35-R	HSJ-35
18	24	5014006-050	KLS-R-045	A6K-45-R	HSJ-45
22	30	5014006-050	KLS-R-050	A6K-50-R	HSJ-50
30	40	5014006-063	KLS-R-060	A6K-60-R	HSJ-60
37	50	5014006-080	KLS-R-075	A6K-80-R	HSJ-80
45	60	5014006-100	KLS-R-100	A6K-100-R	HSJ-100

Power		SIBA	Littelfuse	Ferraz Shawmut	
[kW]	[hp]	Type RK1	Type RK1	Type RK1	Type J
55	75	2028220-125	KLS-R-125	A6K-125-R	HSJ-125
75	100	2028220-150	KLS-R-150	A6K-150-R	HSJ-150
90	125	2028220-200	KLS-R-175	A6K-175-R	HSJ-175

525-690 V

Power		Bussmann		
[kW]	[hp]	E52273 RK1/JDDZ	E4273 J/JDDZ	E4273 T/JDDZ
11	15	KTS-R-30	JKS-30	JJS-30
15	20	KTS-R-30	JKS-30	JJS-30
18	25	KTS-R-45	JKS-45	JJS-45
22	30	KTS-R-45	JKS-45	JJS-45
30	40	KTS-R-60	JKS-60	JJS-60
37	50	KTS-R-80	JKS-80	JJS-80
45	60	KTS-R-90	JKS-90	JJS-90
55	75	KTS-R-100	JKS-100	JJS-100
75	100	KTS-R-125	JKS-125	JJS-125
90	125	KTS-R-150	JKS-150	JJS-150

Power		SIBA	Littelfuse	Ferraz Shawmut	
[kW]	[hp]	E180276 RK1/JDDZ	E81895 RK1/JDDZ	E163267/E2137 RK1/JDDZ	E2137 J/HSJ
11	15	5017906-030	KLS-R-030	A6K-30-R	HST-30
15	20	5017906-030	KLS-R-030	A6K-30-R	HST-30
18	25	5014006-050	KLS-R-045	A6K-45-R	HST-45
22	30	5014006-050	KLS-R-045	A6K-45-R	HST-45
30	40	5014006-063	KLS-R-60	A6K-60-R	HST-60
37	50	5014006-080	KLS-R-75	A6K-80-R	HST-80
45	60	5014006-100	KLS-R-90	A6K-90-R	HST-90
55	75	5014006-100	KLS-R-100	A6K-100-R	HST-100
75	100	2028220-125	KLS-R-150	A6K-125-R	HST-125
90	125	2028220-150	KLS-R-175	A6K-150-R	HST-150

Enclosures D1h-D7h

380-500 V, power/semiconductor fuse options

Power		Bussmann		Littelfuse	
[kW]	[hp]				
110	150	170M2619	FWH-300A	LA50QS300-4	L50S-300
132	200	170M2620	FWH-350A	LA50QS350-4	L50S-350
160	250	170M2621	FWH-400A	LA50QS400-4	L50S-400
200	300	170M4015	FWH-500A	LA50QS500-4	L50S-500
250	350	170M4016	FWH-600A	LA50QS600-4	L50S-600
315	450	170M4017	FWH-800A	LA50QS800-4	L50S-800

Power		Siba	Ferraz Shawmut		
[kW]	[hp]		Europe		North America
110	150	20 189 20.315	A50QS300-4	6,9URD31D08A0315	A070URD31KI0315
132	200	20 189 20.340	A50QS350-4	6,9URD31D08A0350	A070URD31KI0350
160	250	20 189 20.400	A50QS400-4	6,9URD31D08A0400	A070URD31KI0400
200	300	20 189 20.550	A50QS500-4	6,9URD31D08A0550	A070URD31KI0550
250	350	20 189 20.630	A50QS600-4	6,9URD31D08A0630	A070URD31KI0630
315	450	20 189 20.800	A50QS800-4	6,9URD31D08A0800	A070URD31KI0800

525-690 V, power/semiconductor fuse options

Power		Bussmann	Siba	Ferraz Shawmut	
[kW]	[hp]			Europe	North America
110	150	170M2619	20 610 31.315	6,9URD31D08A0315	A070URD31KI0315
132	200	170M2619	20 610 31.315	6,9URD31D08A0350	A070URD31KI0350
160	250	170M2619	20 610 31.315	6,9URD31D08A0400	A070URD31KI0400
200	300	170M4015	20 620 31.550	6,9URD31D08A0550	A070URD31KI0550
250	350	170M4015	20 620 31.550	6,9URD31D08A0630	A070URD31KI0630
315	450	170M4015	20 620 31.550	6,9URD31D08A0800	A070URD31KI0800

Space heater fuse recommendation

Rating		Bussmann
Current [A]	Supply voltage [V]	
2.5	600	LPJ-21/2SP

Enclosures E1h and E2h**380-500 and 525-690 V**

Supply voltage [V]	Bussmann
380-500	170M7309
525-690	170M7342

Space heater fuse recommendation

Rating		Bussmann
Current [A]	Supply voltage [V]	
2.5	600	LPJ-21/2SP

1. 中国 RoHS

产品中有害物质的名称及含有信息表

部件名称	有害物质									
	铅 (Pb)	汞 (Hg)	镉 (Cd)	六价 铬 (Cr6+)	多溴 联苯 (PBBs)	多溴二 苯醚 (PBDEs)	邻苯二甲 酸二正丁 酯 (DBP)	邻苯二甲 酸二 异丁酯 (DIBP)	邻苯二甲酸 丁基苄酯 (BBP)	邻苯二甲酸二 (2-乙基)己酯 (DEHP)
印刷电路板	X	0	0	0	0	0	0	0	0	0
紧固件	X	0	0	0	0	0	0	0	0	0
注 1: 0: 表示该有害物质在该部件所有均质材料中的含量均不超出电器电子产品有害物质限制使用国家标准要求。 X: 表示该有害物质至少在该部件的某一均质材料中含量超出电器电子产品有害物质限制使用国家标准要求。 注 2: 以上未列出的部件, 表明其有害物质含量均不超出电器电子产品有害物质限制使用国家标准要求。										



Declaration of conformity

GB: EC/EU declaration of conformity

We, Grundfos, declare under our sole responsibility that the product CUE, to which the declaration below relates, is in conformity with the Council Directives listed below on the approximation of the laws of the EC/EU member states.

CZ: ES/EU prohlášení o shodě

My společnost Grundfos prohlašujeme na svou plnou odpovědnost, že výrobek CUE, na který se toto prohlášení vztahuje, je v souladu s níže uvedenými ustanoveními směrnice Rady pro sblížení právních předpisů členských států ES/EU.

DK: EF/EU-overensstemmelseerklæring

Vi, Grundfos, erklærer under ansvar at produktet CUE som erklæringen nedenfor omhandler, er i overensstemmelse med Rådets direktiver der er nævnt nedenfor, om indbyrdes tilnærmelse til EF/EU-medlemsstaternes lovgivning.

ES: Declaración de conformidad de la CE/UE

Grundfos declara, bajo su exclusiva responsabilidad, que el producto al que concierne la presente declaración, marcado con la denominación CUE, es conforme con las Directivas del Consejo que figuran a continuación, basadas en la aproximación de las legislaciones correspondientes de los Estados miembros de la CE/UE.

FR : Déclaration de conformité CE/UE

Nous, Grundfos, déclarons sous notre entière responsabilité que le produit CUE auquel la déclaration ci-dessous fait référence, est conforme aux directives du Conseil répertoriées ci-dessous, concernant le rapprochement des législations des États membres de la CE et de l'UE.

HU: EC/EU megfeleléségi nyilatkozat

Mi, a Grundfos vállalat, teljes felelősséggel kijelentjük, hogy a(z) CUE termék, amelyre az alábbi nyilatkozat vonatkozik, megfelel az Európai Közösség/Európai Unió tagállamainak jogi irányelveit összehangoló tanács alábbi előírásainak.

LT: EB/ES atitikties deklaracija

Mes, „Grundfos“, su visa atsakomybe pareiškiamo, kad produktas CUE, kuriam skirta ši deklaracija, atitinka toliau nurodytas Tarybos Direktyvas dėl EB/ES šalių narių įstatymų suderinimo.

BG: Декларация за съответствие на ЕС/ЕО

Ние, Grundfos, декларираме с пълната си отговорност, че продуктът CUE, за който се отнася настоящата декларация, отговаря на следните директиви на Съвета за уеднаквяване на правните разпоредби на държавите-членки на ЕС/ЕО.

DE: EG-/EU-Konformitätserklärung

Wir, Grundfos, erklären in alleiniger Verantwortung, dass das Produkt CUE, auf das sich diese Erklärung bezieht, mit den folgenden Richtlinien des Rates zur Angleichung der Rechtsvorschriften der EG-/EU-Mitgliedsstaaten übereinstimmt.

EE: EÜ/ELI vastavusdeklaratsioon

Meie, Grundfos, kinnitame ja kanname ainuisikulist vastutust selle eest, et toode CUE, mille kohta allolev deklaratsioon käib, on kooskõlas Nõukogu Direktiividega, mis on nimetatud allpool vastavalt vastuvõetud õigusaktidele ühtlustamise kohta EÜ/ELi liikmesriikides.

FI: EY/EU-vaatimustenmukaisuusvakuutus

Grundfos vakuuttaa omalla vastuullaan, että tuote CUE, jota tämä vakuutus koskee, on EY/ EU:n jäsenvaltioiden lainsäädännön lähentämiseen tähtäävien Euroopan neuvoston direktiivien vaatimusten mukainen seuraavasti.

GR: Δήλωση συμμόρφωσης EK/EE

Εμείς, η Grundfos, δηλώνουμε με αποκλειστικά δική μας ευθύνη ότι το προϊόν CUE, στο οποίο αναφέρεται η παρακάτω δήλωση, συμμορφώνεται με τις παρακάτω Οδηγίες του Συμβουλίου περί προσγγίσις των νομοθεσιών των κρατών μελών της EK/EE.

IT: Dichiarazione di conformità CE/UE

Grundfos dichiara sotto la sua esclusiva responsabilità che il prodotto CUE, al quale si riferisce questa dichiarazione, è conforme alle seguenti direttive del Consiglio riguardanti il riavvicinamento delle legislazioni degli Stati membri CE/UE.

LV: EK/ES atbilstības deklarācija

Uzņēmums Grundfos ar pilnu atbildību paziņo, ka produkts CUE, uz kuru attiecas tālāk redzamā deklarācija, atbilst tālāk norādītajām Padomes direktīvām par EK/ES dalībvalstu normatīvo aktu tuvināšanu.

NL: EG/EU-conformiteitsverklaring

Wij, Grundfos, verklaren geheel onder eigen verantwoordelijkheid dat product CUE, waarop de onderstaande verklaring betrekking heeft, in overeenstemming is met de onderstaande Richtlijnen van de Raad inzake de onderlinge aanpassing van de wetgeving van de EG-/EU-lidstaten.

PT: Declaração de conformidade CE/UE

A Grundfos declara sob sua única responsabilidade que o produto CUE, ao qual diz respeito a declaração abaixo, está em conformidade com as Diretivas do Conselho sobre a aproximação das legislações dos Estados Membros da CE/UE.

SR: EZ/EU deklaracija o usklađenosti

Mi, Grundfos, izjavljujemo na našu isključivu odgovornost da je proizvod CUE, na koji se dole navedena deklaracija odnosi, u skladu sa dole navedenim Direktivama Saveta o usklađivanju zakona zemalja članica EZ/EU.

SE: EG/EU-försäkran om överensstämmelse

Vi, Grundfos, försäkrar under ansvar att produkten CUE, som omfattas av nedanstående försäkran, är i överensstämmelse med de rådsdirektiv om inbördes närmande till EG/EU-medlemsstaternas lagstiftning som listas nedan.

UA: Декларація відповідності директивам ЕС/ЕУ

Ми, компанія Grundfos, під нашу одноосібну відповідальність заявляємо, що виріб CUE, до якого відноситься нижченаведена декларація, відповідає директивам Ради, переліченим нижче, щодо тотожності законів країн-членів ЄС.

KO: EC/EU 적합성 선언

Grundfos는 아래의 선언과 관련된 CUE 제품이 EC/EU 회원국 법률에 기반하여 아래의 이사회 지침을 준수함을 단독 책임 하에 선언합니다.

PL: Deklaracja zgodności WE/UE

Firma Grundfos oświadcza z pełną odpowiedzialnością, że jej produkt CUE, którego dotyczy niniejsza deklaracja, jest zgodny z następującymi dyrektywami Rady w sprawie zbliżenia przepisów prawnych państw członkowskich WE/UE.

RO: Declarație de conformitate CE/UE

Subscrisa, Grundfos, declară pe propria răspundere că produsul CUE, la care se referă declarația de mai jos, este în conformitate cu Directivele Consiliului enumerate mai jos privind apropierea legislațiilor statelor membre CE/UE.

RU: Декларация о соответствии нормам ЕЭС/ЕС

Мы, компания Grundfos, со всей ответственностью заявляем, что изделие CUE, к которому относится нижеприведённая декларация, соответствует нижеприведённым Директивам Совета Евросоюза о тождественности законов стран-членов ЕЭС/ЕС.

TR: AT/AB uygunluk beyanı

Grundfos olarak, aşağıdaki bildirim konusu olan CUE ürünlerinin, AT/AB üye ülkelerinin direktiflerinin yakınlştırılmasıyla ilgili aşağıdaki Konsey Direktifleriyle uyumlu olduğunu ve bununla ilgili olarak tüm sorumluluğun bize ait olduğunu beyan ederiz.

CN:欧共体/欧盟符合性声明

我们，格兰富，在我们的全权责任下声明，产品 CUE，即本声明所指之产品，符合欧共体/欧盟使其成员国法律趋于一致的以下理事会指令。

AR: إقرار مطابقة EC/EU

نقرر نحن، جرونذفوس، بمقتضى مسؤوليتنا الفردية بأن المنتج CUE الذي يختص به الإقرار أدناه يكون مطابقاً لتوجيهات المجلس المذكورة أدناه بشأن التقريب بين قوانين الدول أعضاء المجموعة الأوروبية/الاتحاد الأوروبي (EC/EU).

- Low Voltage Directive (2014/35/EU).
Standard used:
EN 61800-5-1:2007.
- EMC Directive (2014/30/EU).
Standard used:
EN 61800-3:2004/A1:2012.
- RoHS Directives 2011/65/EU and 2015/863/EU
Standard used:
EN IEC 63000:2018.
- Ecodesign Directive (2009/125/EC)
 - Commission Regulation (EU) 2019/1781
 - Commission Regulation (EU) 2021/341.Standard used:
EN 61800-9-2:2017.

This EC/EU declaration of conformity is only valid when published as part of the Grundfos safety instructions (99674140).

Bjerringbro, 31st August 2021



Jimm Feldborg
Head of PD IND
Grundfos Holding A/S
Poul Due Jensens Vej 7
8850 Bjerringbro, Denmark
www.grundfos.com

Person authorised to compile technical file and empowered to sign the EC/EU declaration of conformity.

Declaration of conformity

UK declaration of conformity

We, Grundfos, declare under our sole responsibility that the product to which the declaration below relates, are in conformity with UK regulations, standards and specifications to which conformity is declared, as listed below:

Valid for Grundfos products:

CUE

- Electrical Equipment (Safety) Regulations 2016
Standard used: EN 61800-5-1: 2007.
- Electromagnetic Compatibility Regulations 2016
Standard used: EN 61800-3: 2004/A1: 2012.
- The Restriction of the Use of Certain Hazardous Substances in Electrical and Electronic Equipment Regulations 2019.
Standard used: EN IEC 63000:2018
- The Ecodesign for Energy-Related Products and Energy Information Regulations 2021
Standard used: EN 61800-9-2:2017.

This UK declaration of conformity is only valid when accompanying Grundfos instructions.

UK Importer: Grundfos Pumps Ltd. Grovebury Road,
Leighton Buzzard, LU7 4TL.

Bjerringbro, 31st August 2021



Jimm Feldborg
Head of PD IND

Grundfos Holding A/S
Poul Due Jensens Vej 7
8850 Bjerringbro, Denmark
www.grundfos.com

Manufacturer and person empowered to sign the UK
declaration of conformity.

10000386932

RUS

CUE

Руководство по эксплуатации

Руководство по эксплуатации на данное изделие является составным и включает в себя несколько частей:

Часть 1: настоящее «Руководство по эксплуатации».

Часть 2: электронная часть «Паспорт. Руководство по монтажу и эксплуатации» размещенная на сайте компании Грундфос. Перейдите по ссылке, указанной в конце документа.

Часть 3: информация о сроке изготовления, размещенная на фирменной табличке изделия.

Сведения о подтверждении соответствия:

Преобразователи частоты CUE подтверждение соответствия требованиям Технических регламентов Таможенного союза: ТР ТС 004/2011 «О безопасности низковольтного оборудования»; ТР ТС 020/2011 «Электромагнитная совместимость технических средств».



KAZ

CUE

Пайдалану бойынша нұсқаулық

Атаулы өнімге арналған пайдалану бойынша нұсқаулық құрамалы болып келеді және келесі бөлімдерден тұрады:

1 бөлім: атаулы «Пайдалану бойынша нұсқаулық»

2 бөлім: Грундфос компаниясының сайтында орналасқан электронды бөлім «Төлқұжат, Құрастыру және пайдалану бойынша нұсқаулық». Құжат соңында көрсетілген сілтеме арқылы өтіңіз.

3 бөлім: өнімнің фирмалық тақтасында орналасқан шығарылған уақыты жөніндегі мәлімет Сәйкестік мәлімдемесі туралы ақпарат:

CUE жиілік түрлендіргіштері арналған типтік жүйелердің типтері бойынша жүйе бойынша техникалық талаптарға сәйкестігін растады: ТР ТС 004/2011 «Низковольтное оборудования безопасности»; ТР ТС 010/2011 «Машиналар мен жабдықтардың қауіпсіздігі туралы»; ТР ТС 020/2011 «Техникалық құралдардың электромагниттік тәуелділігі».

KG

CUE

Пайдалануу боюнча колдонмо

Аталган жабдууну пайдалануу боюнча колдонмо курамдык жана өзүнө бир нече бөлүкчөнү камтыйт:

1-Бөлүк: «Пайдалануу боюнча колдонмо»

2-Бөлүк: «Паспорт. Пайдалануу жана монтаж боюнча колдонмо» электрондук бөлүгү Грундфос компаниянын сайтында жайгашкан. Документтин аягында көрсөтүлгөн шилтемеге кайрылыңыз.

3-Бөлүк: жабдуунун фирмалык тактасында жайгашкан даярдоо мөөнөтү тууралуу маалымат.

Шайкештикти баалоо боюнча маалымат алуу үчүн:

Ыштык өзгөртүүчүлөр CUE Бажы биримдигинин техникалык регламенттердин талаптарынын сакталышына тастыктоосунан өткөн: ТР ТС 004/2011 "начардыгы жабдуулардын коопсуздугу жөнүндө"; ТР ТС 010/2011 "машиналардын жана жабдуулардын коопсуздугу жөнүндө"; ТР ТС

020/2011 "техникалык каражаттардын электромагниттик келүүчүлүк".

ARM

CUE

Շահագործման ձեռնարկ

Տվյալ սարքավորման շահագործման ձեռնարկը բաղկացած է մի քանի մասերից.

Մաս 1. սույն «Շահագործման ձեռնարկ»:

Մաս 2. էլեկտրոնային մաս. այն է՝ «Անձնագիր: Մոնիտավան և

շահագործման ձեռնարկ» տեղադրված «Գրունդֆոս». Անցեք փաստաթղթի վերջում նշված հղումով.

Մաս 3. տեղեկություն արտադրման ամսաթվի վերաբերյալ՝ նշված սարքավորման պիտակի վրա:

Համապատասխանության մասին հայտարարության տեղեկություններ՝

CUE հաճախականության կոնվերտեր հավաստագրված են Մաքսային միության տեխնիկական կանոնակարգի պահանջներին համապատասխան՝ TP TC 004/2011 «Ցածր լարման սարքավորումների անվտանգության մասին»; TP TC 010/2011 «Մեքենաների եւ սարքավորումների անվտանգության մասին»; TP TC 020/2011 «Տեխնիկական սարքավորումների էլեկտրամագնիսական համատեղելիություն»:

CUE 0,55–90 կԵԷ:<http://net.grundfos.com/gr/i/99035178>**CUE 110-250 կԵԷ:**<http://net.grundfos.com/gr/i/99449240>

10000236994 10.2023

ECM: 1378474

Argentina

Bombas GRUNDFOS de Argentina S.A.
Ruta Panamericana km. 37.500 Industrias
1619 - Garin Pcia. de B.A.
Tel.: +54-3327 414 444
Fax: +54-3327 45 3190

Australia

GRUNDFOS Pumps Pty. Ltd.
P.O. Box 2040
Regency Park
South Australia 5942
Tel.: +61-8-8461-4611
Fax: +61-8-8340-0155

Austria

GRUNDFOS Pumpen Vertrieb
Ges.m.b.H.
Grundfosstraße 2
A-5082 Grödig/Salzburg
Tel.: +43-6246-883-0
Fax: +43-6246-883-30

Belgium

N.V. GRUNDFOS Bellux S.A.
Boomssesteenweg 81-83
B-2630 Aartselaar
Tel.: +32-3-870 7300
Fax: +32-3-870 7301

Bosnia and Herzegovina

GRUNDFOS Sarajevo
Zmajia od Bosne 7-7A
BiH-71000 Sarajevo
Tel.: +387 33 592 480
Fax: +387 33 590 465
www.ba.grundfos.com
E-mail: grundfos@bih.net.ba

Brazil

BOMBAS GRUNDFOS DO BRASIL
Av. Humberto de Alencar Castelo
Branco, 630
CEP 09850 - 300
São Bernardo do Campo - SP
Tel.: +55-11 4393 5533
Fax: +55-11 4343 5015

Bulgaria

Grundfos Bulgaria EOOD
Slatina District
Iztocna Tangenta street no. 100
BG - 1592 Sofia
Tel.: +359 2 49 22 200
Fax: +359 2 49 22 201
E-mail: bulgaria@grundfos.bg

Canada

GRUNDFOS Canada inc.
2941 Brighton Road
Oakville, Ontario
L6H 6C9
Tel.: +1-905 829 9533
Fax: +1-905 829 9512

China

GRUNDFOS Pumps (Shanghai) Co. Ltd.
10F The Hub, No. 33 Suhong Road
Minhang District
Shanghai 201106 PRC
Tel.: +86 21 612 252 22
Fax: +86 21 612 253 33

Colombia

GRUNDFOS Colombia S.A.S.
Km 1.5 vía Siberia-Cota Conj. Potrero
Chico,
Parque Empresarial Arcos de Cota Bo. 1A.
Cota, Cundinamarca
Tel.: +57(1)-2913444
Fax: +57(1)-8764586

Croatia

GRUNDFOS CROATIA d.o.o.
Buzinski prilaz 38, Buzin
HR-10010 Zagreb
Tel.: +385 1 6595 400
Fax: +385 1 6595 499
www.hr.grundfos.com

Czech Republic

GRUNDFOS Sales Czechia and Slovakia
s.r.o.
Čajkovského 21
779 00 Olomouc
Tel.: +420-585-716 111

Denmark

GRUNDFOS DK A/S
Martin Bachs Vej 3
DK-8850 Bjerringbro
Tel.: +45-87 50 50 50
Fax: +45-87 50 51 51
E-mail: info_GDK@grundfos.com
www.grundfos.com/DK

Estonia

GRUNDFOS Pumps Eesti OÜ
Peterburi tee 92G
11415 Tallinn
Tel.: + 372 606 1690
Fax: + 372 606 1691

Finland

OY GRUNDFOS Pumput AB
Trukkikujua 1
FI-01360 Vantaa
Tel.: +358-(0) 207 889 500

France

Pompes GRUNDFOS Distribution S.A.
Parc d'Activités de Chesnes
57, rue de Malacombe
F-38290 St. Quentin Fallavier (Lyon)
Tel.: +33-4 74 82 15 15
Fax: +33-4 74 94 10 51

Germany

GRUNDFOS GMBH
Schlüterstr. 33
40699 Erkrath
Tel.: +49-(0) 211 929 69-0
Fax: +49-(0) 211 929 69-3799
E-mail: infoservice@grundfos.de
Service in Deutschland:
kundendienst@grundfos.de

Greece

GRUNDFOS Hellas A.E.B.E.
20th km. Athinon-Markopoulou Av.
P.O. Box 71
GR-19002 Peania
Tel.: +0030-210-66 83 400
Fax: +0030-210-66 46 273

Hong Kong

GRUNDFOS Pumps (Hong Kong) Ltd.
Unit 1, Ground floor, Siu Wai industrial
Centre
29-33 Wing Hong Street & 68 King Lam
Street, Cheung Sha Wan
Kowloon
Tel.: +852-27861706 / 27861741
Fax: +852-27858664

Hungary

GRUNDFOS South East Europe Kft.
Tópark u. 8
H-2045 Törökbálint
Tel.: +36-23 511 110
Fax: +36-23 511 111

India

GRUNDFOS Pumps India Private
Limited
118 Old Mahabalipuram Road
Thoraiappakam
Chennai 600 097
Tel.: +91-44 2496 6800

Indonesia

PT GRUNDFOS Pompa
Graha intrub Lt. 2 & 3
Jln. Cililitan Besar No.454. Makasar,
Jakarta Timur
ID-Jakarta 13650
Tel.: +62 21-469-51900
Fax: +62 21-460 6910 / 460 6901

Ireland

GRUNDFOS (Ireland) Ltd.
Unit A, Merrywell Business Park
Ballymount Road Lower
Dublin 12
Tel.: +353-1-4089 800
Fax: +353-1-4089 830

Italy

GRUNDFOS Pompe Italia S.r.l.
Via Gran Sasso 4
I-20060 Truccazzano (Milano)
Tel.: +39-02-95838112
Fax: +39-02-95309290 / 95838461

Japan

GRUNDFOS Pumps K.K.
1-2-3, Shin-Miyakoda, Kita-ku
Hamamatsu
431-2103 Japan
Tel.: +81 53 428 4760
Fax: +81 53 428 5005

Kazakhstan

Grundfos Kazakhstan LLP
7' Kyz-Zhibek Str., Kok-Tobe micr.
KZ-050020 Almaty Kazakhstan
Tel.: +7 (727) 227-98-55/56

Korea

GRUNDFOS Pumps Korea Ltd.
6th Floor, Aju Building 679-5
Yeoksam-dong, Kangnam-ku, 135-916
Seoul, Korea
Tel.: +82-2-5317 600
Fax: +82-2-5633 725

Latvia

SIA GRUNDFOS Pumps Latvia
Deglava biznesa centrs
Augusta Deglava ielā 60
LV-1035, Rīga,
Tel.: + 371 714 9640, 7 149 641
Fax: + 371 914 9646

Lithuania

GRUNDFOS Pumps UAB
Smolensko g. 6
LT-03201 Vilnius
Tel.: +370 52 395 430
Fax: +370 52 395 431

Malaysia

GRUNDFOS Pumps Sdn. Bhd.
7 Jalan Peguam U1/25
Glenmarie Industrial Park
40150 Shah Alam, Selangor
Tel.: +60-3-5569 2922
Fax: +60-3-5569 2866

Mexico

Bombas GRUNDFOS de México
S.A. de C.V.
Boulevard TLC No. 15
Parque industrial Stiva Aeropuerto
Apodaca, N.L. 66600
Tel.: +52-81-8144 4000
Fax: +52-81-8144 4010

Netherlands

GRUNDFOS Netherlands
Veluwezoom 35
1326 AE Almere
Postbus 22015
1302 CA ALMERE
Tel.: +31-88-478 6336
Fax: +31-88-478 6332
E-mail: info_gnl@grundfos.com

New Zealand

GRUNDFOS Pumps NZ Ltd.
17 Beatrice Tinsley Crescent
North Harbour Industrial Estate
Albany, Auckland
Tel.: +64-9-415 3240
Fax: +64-9-415 3250

Norway

GRUNDFOS Pumper A/S
Strømsveien 344
Postboks 235, Leirdal
N-1011 Oslo
Tel.: +47-22 90 47 00
Fax: +47-22 32 21 50

Poland

GRUNDFOS Pompy Sp. z o.o.
ul. Klonowa 23
Baranowo k. Poznania
PL-62-081 Przeźmierowo
Tel.: (+48-61) 650 13 00
Fax: (+48-61) 650 13 50

Portugal

Bombas GRUNDFOS Portugal, S.A.
Rua Calvet de Magalhães, 241
Apartado 1079
P-2770-153 Paço de Arcos
Tel.: +351-21-440 76 00
Fax: +351-21-440 76 90

Romania

GRUNDFOS Pompe România SRL
S-PARK BUSINESS CENTER, Clădirea
A2, etaj 2
Str. Tipografilor, Nr. 11-15, Sector 1, Cod
013714
Bucuresti, Romania
Tel.: 004 021 2004 100
E-mail: romania@grundfos.ro

Serbia

Grundfos Srbija d.o.o.
Orladijskih brigada 90b
11070 Novi Beograd
Tel.: +381 11 2258 740
Fax: +381 11 2281 769
www.rs.grundfos.com

Singapore

GRUNDFOS (Singapore) Pte. Ltd.
25 Jalan Tukang
Singapore 619264
Tel.: +65-6681 9688
Fax: +65-6681 9689

Slovakia

GRUNDFOS s.r.o.
Prievozská 4D 821 09 BRATISLAVA
Tel.: +421 2 5020 1426
sk.grundfos.com

Slovenia

GRUNDFOS LJUBLJANA, d.o.o.
Leskoškova 9e, 1122 Ljubljana
Tel.: +386 (0) 1 568 06 10
Fax: +386 (0) 1 568 06 19
E-mail: tehnika-si@grundfos.com

South Africa

GRUNDFOS (PTY) LTD
16 Lascelles Drive, Meadowbrook Estate
1609 Germiston, Johannesburg
Tel.: (+27) 10 248 6000
Fax: (+27) 10 248 6002
E-mail: lgradidge@grundfos.com

Spain

Bombas GRUNDFOS España S.A.
Camino de la Fuentecilla, s/n
E-28110 Algete (Madrid)
Tel.: +34-91-848 8800
Fax: +34-91-628 0465

Sweden

GRUNDFOS AB
Box 333 (Lunnagårdsgatan 6)
431 24 Mölndal
Tel.: +46 31 332 23 000
Fax: +46 31 331 94 60

Switzerland

GRUNDFOS Pumpen AG
Bruggacherstrasse 10
CH-8117 Fällanden/ZH
Tel.: +41-44-806 8111
Fax: +41-44-806 8115

Taiwan

GRUNDFOS Pumps (Taiwan) Ltd.
7 Floor, 219 Min-Chuan Road
Taichung, Taiwan, R.O.C.
Tel.: +886-4-2305 0868
Fax: +886-4-2305 0878

Thailand

GRUNDFOS (Thailand) Ltd.
92 Chaloe Phrakiat Rama 9 Road
Dokmai, Pravej, Bangkok 10250
Tel.: +66-2-725 8999
Fax: +66-2-725 8998

Turkey

GRUNDFOS POMPA San. ve Tic. Ltd.
Sti.
Gebze Organize Sanayi Bölgesi
Ihsan dede Caddesi
2. yol 200, Sokak No. 204
41490 Gebze/ Kocaeli
Tel.: +90 - 262-679 7979
Fax: +90 - 262-679 7905
E-mail: satis@grundfos.com

Ukraine

ТОВ "ГРУНДФОС УКРАЇНА"
Бізнес Центр Європа
Столичне шосе, 103
м. Київ, 03131, Україна
Tel.: (+38 044) 237 04 00
Fax: (+38 044) 237 04 01
E-mail: ukraine@grundfos.com

United Arab Emirates

GRUNDFOS Gulf Distribution
P.O. Box 16768
Jebel Ali Free Zone, Dubai
Tel.: +971 4 8815 166
Fax: +971 4 8815 136

United Kingdom

GRUNDFOS Pumps Ltd.
Grovebury Road
Leighton Buzzard/Beds. LU7 4TL
Tel.: +44-1525-850000
Fax: +44-1525-850011

U.S.A.

Global Headquarters for WU
856 Koomey Road
Brookshire, Texas 77423 USA
Phone: +1-630-236-5500

Uzbekistan

Grundfos Tashkent, Uzbekistan
The Representative Office of Grundfos
Kazakhstan in Uzbekistan
38a, Oybek street, Tashkent
Tel.: (+998) 71 150 3290 / 71 150 3291
Fax: (+998) 71 150 3292

99674140 08.2025

ECM: 1424425

www.grundfos.com

GRUNDFOS 

© 2025 Grundfos Holding A/S, all rights reserved.

Trademarks displayed in this material, including but not limited to Grundfos and the Grundfos logo, are registered trademarks owned by The Grundfos Group.