

CLEVELAND CONTROLS

Model AFS-305

Air Pressure Sensing Switch with Manual Reset Feature (SPDT)

Application

The Model AFS-305 is a general purpose proving switch designed to require manual operator reset following actuation. It can be used to sense positive, negative, or differential air pressure in HVAC and Energy Management applications which require operator interface.

General Description & Operation

The plated housing contains a diaphragm, a calibration spring and a snap-acting SPDT switch with manual reset button.

The sample connections located on each side of the diaphragm accept 0.25" OD metallic tubing via the integral compression ferrule and nut.

An enclosure cover protects the operator from accidental contact with the live switch terminal screws and the set point adjusting screw. The enclosure cover accepts a 0.5" conduit connection.

Dimensions in Inches
(Millimeters)

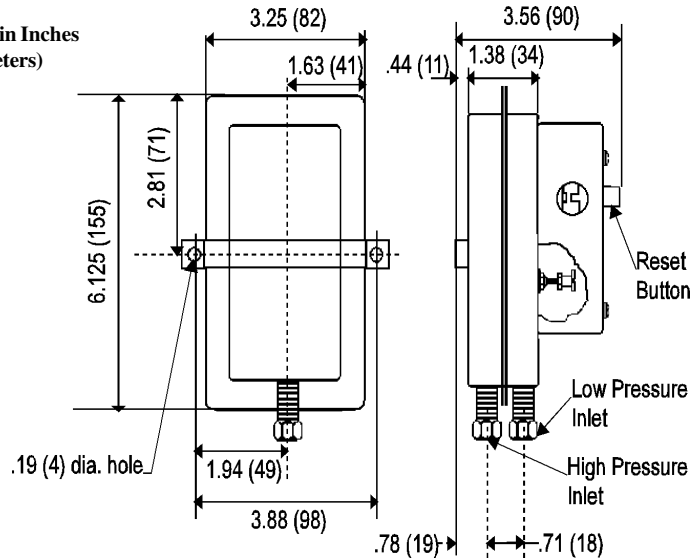

Mounting (see Figure 1)

Select a mounting location which is free from vibration. The AFS-305 must be mounted with the diaphragm in any vertical plane in order to obtain the lowest specified operating set point. Avoid mounting with the sample line connections in the "up" position. Surface mount via the two 3/16" diameter holes in the integral mounting bracket. The mounting holes are 3-7/8" apart.

For lines up to 60 feet, use 1/2" ID tubing. Locate the sampling probe a minimum of 1.5 duct diameters downstream from the air source. Install the sampling probe as close to the center of the airstream as possible. Refer to Figure 2 to identify the high pressure inlet (H) and the low pressure inlet (L). Select one of the five application options listed on page 2, and connect the sample lines as recommended.

Air Sampling Connection (see Figure 2)

The AFS-305 is designed to accept firm-wall sample lines of 1/4" OD tubing by means of ferrule and nut compression connections. An optional 1/4" adapter, suitable for slip-on flexible tubing is available: order part number 18311. For sample lines of up to 10 feet, 1/4" OD tubing is acceptable. For lines up to 20 feet, use 1/4" ID tubing.

(Figure 1)

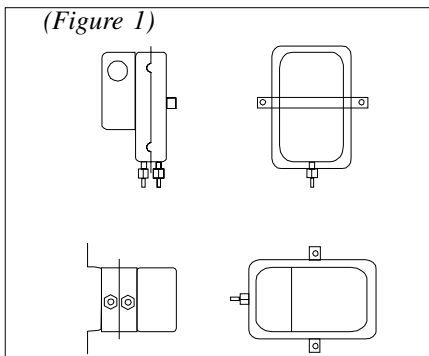

(Figure 2)

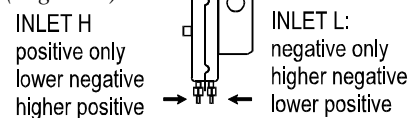

(Figure 3)

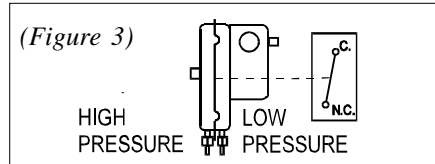

Cleveland Controls
Division of UniControl Inc.

111 Brookpark Road • Cleveland OH 44109
TEL: (216) 398-0330 • FAX: (216) 398-8558

Distributed by:

(Figure 4)

To prove excessive air flow or pressure:

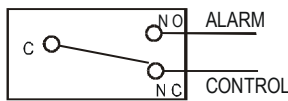

To prove insufficient air flow or pressure:

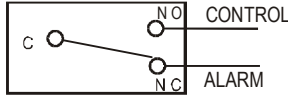

POSITIVE PRESSURE ONLY: Connect the sample line to inlet H; inlet L remains open to the atmosphere.

NEGATIVE PRESSURE ONLY: Connect the sample line to inlet L; inlet H remains open to the atmosphere.

TWO NEGATIVE SAMPLES: Connect the higher negative sample to inlet L. Connect the lower negative sample to inlet H.

TWO POSITIVE SAMPLES: Connect the higher positive sample to inlet H. Connect the lower positive sample to inlet L.

ONE POSITIVE AND ONE NEGATIVE SAMPLE: Connect the positive sample to inlet H. Connect the negative sample to inlet L.

Electrical Connections (see Figure 3)

Before pressure is applied to the diaphragm, the switch contacts will be in the normally closed (NC) position.

The snap switch has screw top terminals with solder connections. Wire alarm and control applications as shown in **Figure 4**.

Field Adjustment

The adjustment range of an **AFS-305** Air Switch is 0.4" ± 0.02" w.c. to 12.0" w.c. To adjust the set point, turn the adjusting screw counterclockwise until motion has stopped. Next, turn the adjusting screw four complete turns in a clockwise direction to engage the spring. From this point, the next ten turns will be used for the actual calibration. **Each full turn represents approximately 1.16" w.c.**

Please note: To properly calibrate an air switch, a digital manometer or other measuring device should be used to confirm the actual set point.

Specifications

Model AFS-305 Air Pressure Sensing Switch with Manual Reset Feature (SPDT)

Sample Media: Air.

Mounting Position (in order to meet lowest operating specifications): Diaphragm in any vertical plane.

Field Adjustable Range: 0.40 ± 0.06"w.c. to 12.0"w.c.

Switch Differential: Progressive, increasing from approximately 0.06± 0.01"w.c. at minimum set point, to approximately 0.8"w.c. at maximum set point.

Maximum Pressure: 0.5 psi (0.03 bar)

Operating Temperature Range: -40 to 180F (-40.0 to 82.2C)

Life: Exceeds UL-recognized mechanical endurance test of 6,000 cycles minimum at 0.5 psi maximum pressure each cycle and at maximum electrical load.

Electrical Rating: @ 60 Hz.

15 amp 125, 250, or 277 VAC

¼ hp 125 V AC, ½Hp 250 VAC, ½ amp 125 V DC,

¼ amp 250 V DC .

Contact Arrangement:

SPDT (manual reset).

Electrical Connections: Screw top terminals with solder lugs.

Sample Line Connections:

Ferrule and nut compression type connectors will accept 0.25" OD rigid tubing.

Shipping Weight: 1.2 lbs.

Location of Sample Lines for Typical Applications

FAN OPERATION OR TRUE AIR FLOW WITH LITTLE OR NO STATIC PRESSURE.

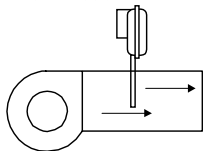

PROBE MUST BE PERPENDICULAR TO FLOW.

FAN OPERATION OR AIR FLOW WITH NO STATIC PRESSURE.

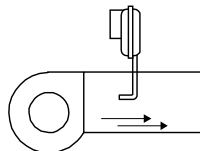

FAN OPERATION AND TRUE AIR FLOW WITH VARYING AMOUNTS OF STATIC PRESSURE.

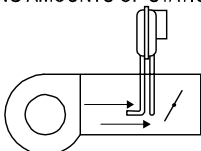

PROBE MUST BE PERPENDICULAR TO FLOW.

SUCTION OR FAN OPERATION.

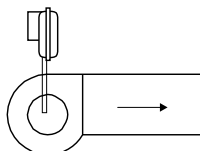

PROVE POSITIVE STATIC PRESSURE.

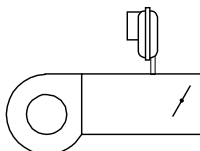

NEGATIVE PRESSURE INCREASES AS FILTER GETS DIRTY.

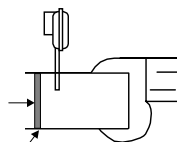

FILTER

Pressure Conversion Table

1" H₂O = 0.0361 lbs./sq. in. or 0.0735 in. mercury

1" Hg. = 0.491 lbs./sq. in. or 13.6 in. water

1 psi = 2.77 in. water or 2.036 in. mercury

Accessories

- P/N 18311 Slip-on ¼" OD Tubing Adapter, suitable for slipping on flexible plastic tubing.
- Sample line probes.
- Orifice plugs (pulsation dampeners).