



AIR PRESSURE SENSING SWITCH WITH FIXED SET POINT

APPLICATION

Model DFSL-CO is an airflow proving switch designed for duct heater, oven, and other HVAC or Energy Management applications where an open-mounted, nonadjustable switch is desirable. It is especially suitable for surface-mounting in areas where a protective enclosure over the switch is required. It can be used to sense positive, negative, or differential air pressure. The DFSL-CO is equipped with a 1/4"-18 NPT female connector and a 1/8"-27 NPT female connector suitable for rigid pipe.

GENERAL DESCRIPTION & OPERATION

The plated housing contains a diaphragm and a snap-acting **SPDT** switch. The sample line connections located on each side of the diaphragm accept rigid pipe. The electrical connection consists of screw terminals with cup washers.

The SPDT snap action switch operates on pressure rise of 0.2"w.c., ± 0.04 " w.c. For additional application and technical information, please contact the sales office.

(Figure 1)

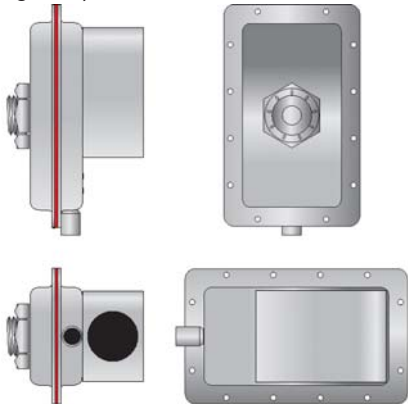

Mount with the diaphragm in any vertical plane to obtain the lowest specified operating set point.



MOUNTING (FIGURE 1)

Select a mounting location which is free from vibration. The DFSL-CO must be mounted with the diaphragm in any vertical plane in order to maintain the specified operating set point. Avoid mounting with the sample line connections in the "up" position. Surface mount to a rigid flange via the 1" - 14 externally threaded connector with PAL nut. This connector is also internally threaded, 1/4"-18 NPT, for rigid mounting to a pipe nipple.

AIR SAMPLING CONNECTION (FIGURE 2)

The **DFSL-CO** is equipped with two sample line connections, situated on either side of the diaphragm. Referring to **Figure 2**, the connectors are (H) 1/4"-18 NPT female connector for the high pressure inlet; and (L) 1/8"-27 NPT female connector for the low pressure inlet. Locate the sampling probe a minimum of 1.5 duct diameters downstream from the air source. Install the

sampling probe as close to the center of the airstream as possible. Select one of the five application options listed below, and connect the sample lines as recommended.

POSITIVE PRESSURE ONLY: Connect the sample line to inlet H; inlet L remains open to the atmosphere.

NEGATIVE PRESSURE ONLY: Connect the sample line to inlet L; inlet H remains open to the atmosphere.

TWO NEGATIVE SAMPLES: Connect the higher negative sample to inlet L. Connect the lower negative sample to inlet H.

TWO POSITIVE SAMPLES: Connect the higher positive sample to inlet H. Connect the lower positive sample to inlet L.

ONE POSITIVE AND ONE NEGATIVE SAMPLE: Connect the positive sample to inlet H. Connect the negative sample to inlet L.

(Figure 2)

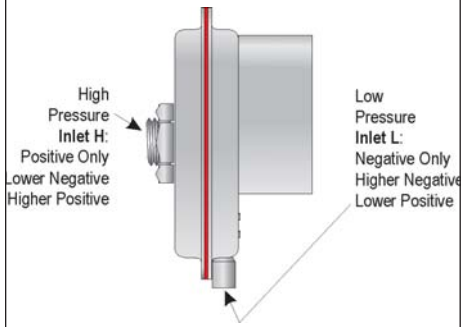

(Figure 3)

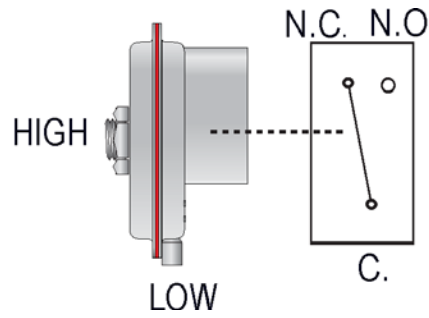

ELECTRICAL CONNECTIONS (FIGURES 3 & 4)

Before pressure is applied to the diaphragm, the switch contacts are in the normally closed (NC) position. Control and alarm functions are wired as shown in **Figure 4**.

(Figure 4)

To prove excessive air flow or pressure:

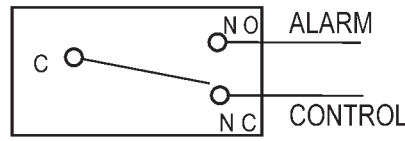

To prove insufficient air flow or pressure:

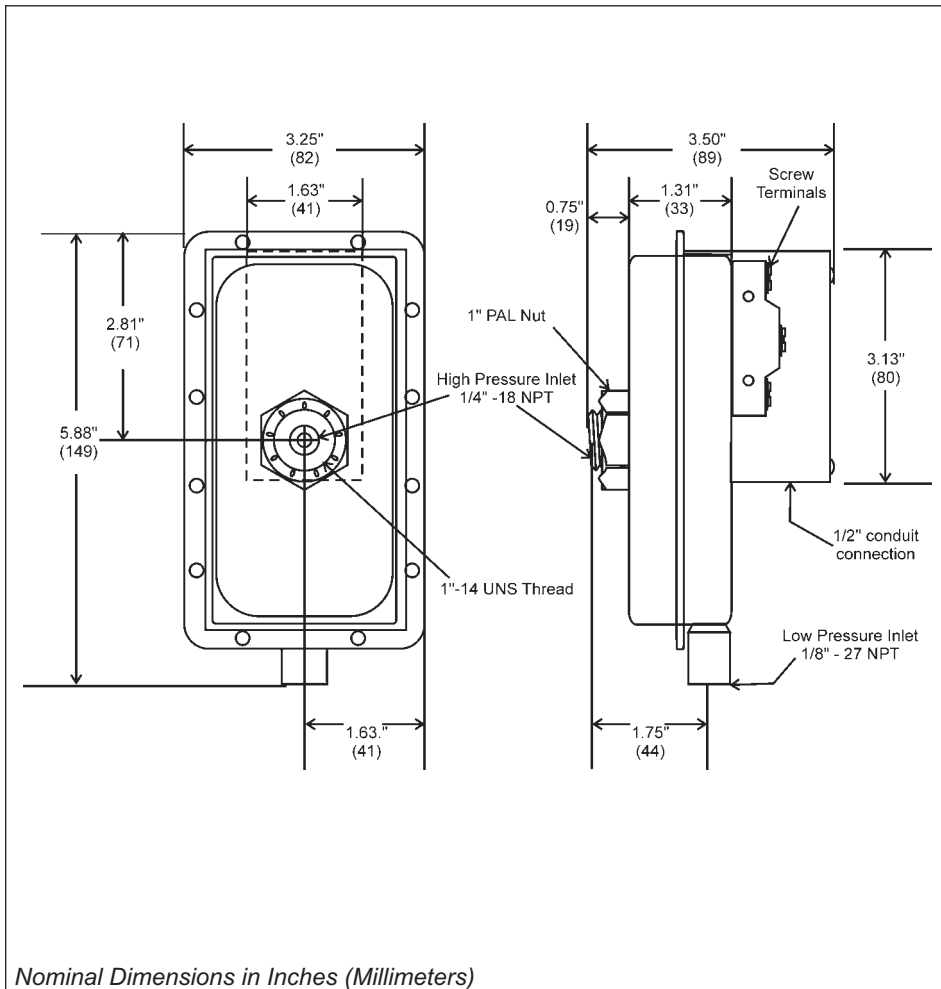
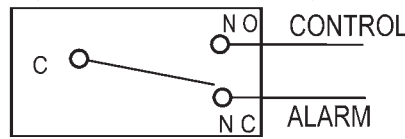

Nominal Dimensions in Inches (Millimeters)

SPECIFICATIONS

CLEVELAND CONTROLS MODEL DFSL-CO AIR PRESSURE SENSING SWITCH WITH FIXED SET POINT

Mounting Position: Mount with the diaphragm in any vertical plane to obtain specified operating set point.

Set Point: Fixed to operate on pressure rise at 0.2 ± 0.04 " w.c. (5.08 ± 1.02 mm).

Measured Media: Air, or combustion by-products that will not degrade silicone.

Maximum Pressure: $\frac{1}{2}$ psi (0.03 bar).

Operating Temperature Range:

-40F to 180F (-40 to 82C).

Life: 100,000 cycles minimum at $\frac{1}{2}$ psi maximum pressure each cycle and at maximum rated electrical load.

Electrical Rating:

300 VA pilot duty at 115 to 277 VAC,

15 amps noninductive to 277 VAC, 60 Hz.

Contact Arrangement: SPDT.

Electrical Connections: Screw terminals with cup washers.

Sample Line Connectors:

(1) $\frac{1}{4}$ "-18 NPT female connector for the high pressure inlet

(1) $\frac{1}{8}$ "-27 NPT female connector for the low pressure inlet

Sample Line Connections: Connectors accept rigid pipe. High pressure connector is equipped with 1" PAL nut for mounting to a rigid flange.

Approval: UL listed, FM, CSA.

Shipping Weight: 1.2 lbs.

Accessories

- Sample line probes.