



# MK8 DTI MANUAL

## DTI80100

29.07.2020



Autoflame Engineering Ltd.  
Unit 1-2 Concorde Business Centre  
Airport Industrial Estate  
Wireless Road, Biggin Hill  
Kent TN16 3YN  
United Kingdom

Tel: +44 (0)1959 578 820

Email: [technicalsupport@autoflame.com](mailto:technicalsupport@autoflame.com)

Web: [www.autoflame.com](http://www.autoflame.com)

---

# MK8 DTI MANUAL

## DTI80100

29.07.2020

---

---

This manual and all the information contained herein is copyright of Autoflame Engineering Ltd. It may not be copied in the whole or part without the consent of the Managing Director.

Autoflame Engineering Ltd's policy is one of continuous improvement in both design and manufacture. We therefore reserve the right to amend specifications and/or data without prior notice. All details contained in this manual are correct at the time of going to print.

### **Important Notes**

A knowledge of combustion related procedures and commissioning is essential before embarking work on any of the MM / EGA systems. This is for safety reasons and effective use of the MM / EGA system. Hands on training is required. For details on schedules and fees relating to group training courses and individual instruction, please contact the Autoflame Engineering Ltd. offices at the address listed on the front.

### **Short Form - General Terms and Conditions**

A full statement of our business terms and conditions are printed on the reverse of all invoices. A copy of these can be issued upon application, if requested in writing.

The System equipment and control concepts referred to in this Manual MUST be installed, commissioned and applied by personnel skilled in the various technical disciplines that are inherent to the Autoflame product range, i.e. combustion, electrical and control.

The sale of Autoflame's systems and equipment referred to in this Manual assume that the dealer, purchaser and installer has the necessary skills at his disposal. i.e. A high degree of combustion engineering experience, and a thorough understanding of the local electrical codes of practice concerning boilers, burners and their ancillary systems and equipment.

### **Autoflame's warranty from point of sale**

- Two years on all electronic systems and components.
- One year on all mechanical systems, components and sensors.

The warranty assumes that all equipment supplied will be used for the purpose that it was intended and in strict compliance with our technical recommendations.

Autoflame's warranty and guarantee is limited strictly to product build quality, and design. Excluded absolutely are any claims arising from misapplication, incorrect installation and/or incorrect commissioning.

# CONTENTS

---

<b>1. MK8 DTI OVERVIEW &amp; SPECIFICATIONS</b> .....	<b>7</b>
1.1. MK8 DTI System Overview.....	7
1.2. Information Available from MK8 DTI.....	8
1.3. Dimensions and Fixing .....	10
1.4. Specifications.....	11
1.4.1. General Specifications.....	11
1.4.2. Fuses .....	11
1.4.3. Cables.....	11
<b>2. MK8 DTI SETUP</b> .....	<b>12</b>
2.1. Mk8 DTI Wiring .....	12
2.2. System Schematic .....	13
2.3. MK8 MM and MK8 EGA EVO with MK8 DTI .....	14
2.4. Mk8 Gas/Air Pressure Sensors with Mk8 DTI .....	15
2.5. Configuring the DTI.....	16
2.6. Resetting Data .....	25
<b>3. BOILER ROOM CONFIGURATION</b> .....	<b>26</b>
3.1. MM and EGA Settings .....	26
3.1.1. Mk8 MM Options and Parameters .....	26
3.1.2. Mini MK8 MM Options and Parameters.....	27
3.1.3. MK8 EGA EVO Options .....	28
3.2. Boiler Set-up .....	29
3.2.1. EGA Changeover.....	31
<b>4. ANALOGUE AND DIGITAL INPUTS/OUTPUTS</b> .....	<b>32</b>
4.1. MK8 Universal Input/ Output Module.....	32
4.1.1. Overview .....	32
4.1.2. Wiring.....	33
4.1.3. Dimensions & Fixing .....	34
4.1.4. Configuring I/O Module.....	35
4.2. Input / Outputs Data.....	44
<b>5. PRESSURE SENSORS</b> .....	<b>45</b>
5.1. MK8 Gas/Air Pressure Sensor.....	45
5.2. Configuring Pressure Sensor.....	46
5.3. Pressure Sensors Data.....	49
<b>6. RULES SYSTEM</b> .....	<b>50</b>
6.1. Introduction .....	50
6.2. Configuring Rules .....	51
<b>7. Mk8 DTI OPERATION</b> .....	<b>56</b>
7.1. Home Screen .....	56
7.2. DTI Faults Log .....	57
7.3. Setpoints.....	58
7.4. Sequencing.....	59

7.5.	Setpoint Control .....	60
7.6.	Firing Rate Control.....	61
7.7.	Sequence Control .....	62
7.8.	System Log.....	65
7.9.	Network Diagnostics .....	66
7.10.	Modbus Diagnostics .....	67
7.11.	Device Conflicts .....	68
7.12.	Upload/Download .....	69
<b>8.</b>	<b>REMOTE ACCESS .....</b>	<b>70</b>
8.1.	PC Connection.....	70
8.1.1.	Direct Connection to PC via Ethernet.....	71
8.1.2.	Local Area Network (LAN) Connection.....	74
8.1.3.	Connecting the DTI to the Internet.....	75
8.2.	RS422 Connection.....	76
8.3.	DTI Manager PC Software.....	77
8.3.1.	Software Requirements .....	77
8.3.2.	Software license.....	78
8.3.3.	Installation.....	78
8.3.4.	Setup and Connect to a Site.....	78
8.3.5.	Connect to a Site .....	80
8.3.6.	Data Accessable from the DTI Manager .....	81
8.3.7.	View and Download Long-Term Logs .....	84
8.3.8.	Mk8 MM and Mk8 Mini MM Logs.....	84
8.3.9.	Mk8 EGA Evo Logs .....	86
8.3.10.	Analogue/ Digital IO Modules Logs .....	88
8.4.	Modbus to BACnet® ProtoNode Gateway .....	89
8.5.	Troubleshooting Remote Connection .....	90
<b>9.</b>	<b>MODBUS .....</b>	<b>91</b>
9.1.	Read Only Addresses.....	91
9.1.1.	DTI .....	91
9.1.2.	Pressure Sensors .....	91
9.1.3.	Mk8 MMs or Mini Mk8 MMs.....	92
9.1.4.	EGAs.....	102
9.1.5.	Input/ Output Modules .....	104
9.1.6.	Totalized Analogue Inputs .....	106
9.2.	Read/ Write Addresses.....	107
9.2.1.	DTI .....	107
9.2.2.	Mk8 MMs or Mini Mk8 MMs.....	107
9.2.3.	Analogue and Digital Outputs.....	108
9.2.4.	Totalized Analogue Inputs .....	109
9.3.	Fault Codes.....	110
9.3.1.	MM Error Codes.....	110
9.3.2.	Lockout Codes.....	112
9.3.3.	Alarms and Warnings .....	114

<b>10. TROUBLESHOOTING .....</b>	<b>117</b>
10.1. Errors and Warnings .....	117
10.2. Device Conflicts .....	118

# 1. **MK8 DTI OVERVIEW & SPECIFICATIONS**

## 1.1. **MK8 DTI System Overview**

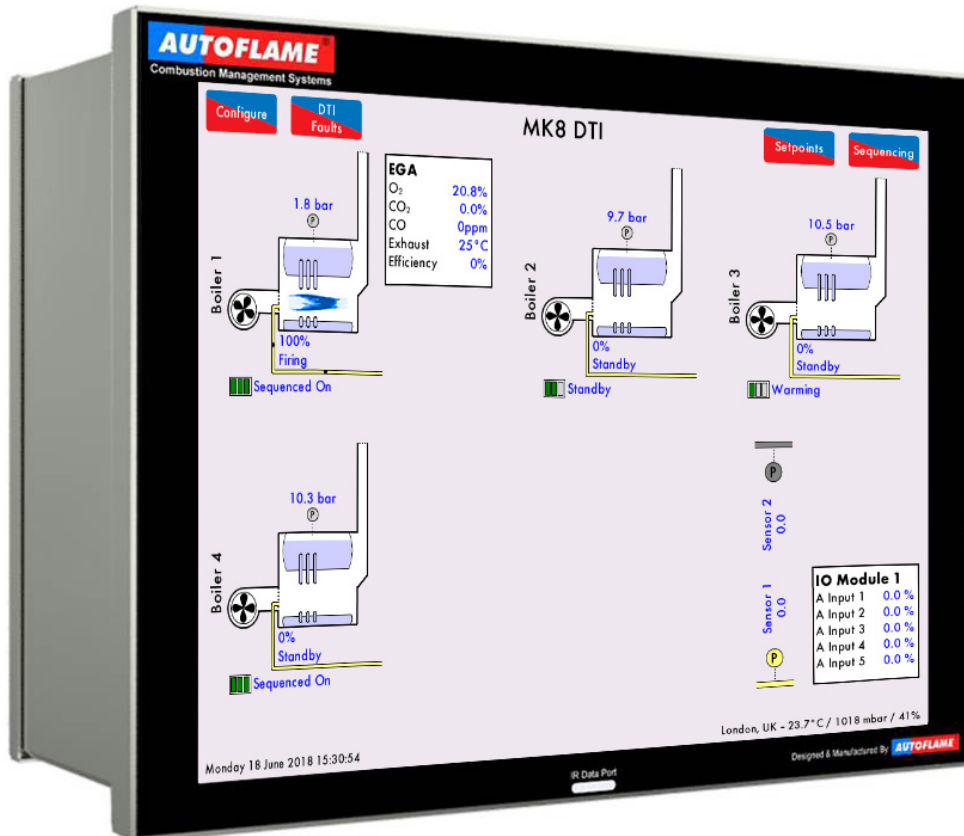

Figure 1.1.1.i: MK8 DTI

The Autoflame Data Transfer Interface (DTI) is the gateway for communications between the MM and EGA range of products. All of the MM operational data, of up to ten MMs in one location, can be collected by the DTI. The information gathered is available for transmission to an external source via RS422 and Ethernet data links. The data gathered by the MK8 DTI can be collected and viewed using the included DTI Manager software, which allows data collection over a Local Area Network (LAN) or over the internet.

Up to a maximum of ten MM modules can be connected to one DTI module. This can be a combination of MK8 MM modules and Mini MK8 MM modules. It is also possible to receive data from up to 10 MK8 EGA EVOs for emissions data. To accommodate the status information from other plant related equipment, the DTI can communicate with up to ten MK8 Universal Input / Output modules. The MK8 DTI also allows collection of Gas and Air pressure data from pressure sensors directly connected to the DTI. A combination of up to ten MK8 Gas and Air pressure sensors can be connected to the module. The information gathered by the DTI from each system is then available for transmission to the Building Management System (BMS) or Energy Management System (EMS). This is done through the RS422 link or Ethernet to send data via Modbus communications. Typical remote BMS information and operational facilities are subject to the particular site and management system requirements.

The Autoflame network operates using a two core screened cable and features dedicated data ports for RS422 and Ethernet connections. The MK8 DTI polls each unit on the network periodically, storing up-to-date information. The DTI then outputs to the defined Modbus addresses, which are then available to third party systems like a BMS. The 12.1" touch-screen displays the operational status of the DTI's communications, with corresponding error conditions in the event of a communication failure.

## 1.2. Information Available from MK8 DTI

The MK8 DTI displays information from the MK8 MM, Mini MK8 MM and MK8 EGA EVO. Remote on/off control of the burners can also be achieved as well as the adjustment of the temperature or pressure setpoint and the sequence order. Through the DTI touch screen, DTI Manager software and via Modbus, the following information is available:

### MK8 DTI Input Values

- Enable/Disable burner
- Change Individual required setpoint
- Change Global required setpoint
- Select Lead boiler
- Shuffle sequencing
- Set load index (firing rate)

### MK8 MM

- Actual boiler temperature (deg. C/F) or pressure (Bar/PSI)
- Required setpoint i.e. required boiler temperature (deg. C/F) or pressure (Bar/PSI)
- Burner on/off status
- Burner firing rate (%)
- Fuel selected
- Burner rating
- Fuel flow metering values
- Load detector type (temperature/pressure)
- Lockout and Error history
- Auto/hand/low flame hold operation
- Number of channels used
- Channel 1,2,3,4,7, servomotor angle
- Channel 5,6 output and input signals to VFD with feedback history
- Burner firing status
- Lead/Lag boiler status
- Sequence order
- Sequence status (on, standby, warming, off)
- Enabled/ disable status
- Total hours run
- Number of start-ups per fuel
- Online and commissioned gas/ oil pressure
- Online and commissioned air pressure
- UV scanner signal history
- Water Level Control (if optioned)

### MK8 EGA EVO

- EGA operation optioned
- Standalone/ MM Operation
- Flue gas O<sub>2</sub> present value
- Flue gas CO<sub>2</sub> present value
- Flue gas CO present value
- Flue gas NO present value
- Flue gas NO<sub>2</sub> present value (if optioned)
- Flue gas SO<sub>2</sub> present value (if optioned)
- Flue gas O<sub>2</sub> commissioned value
- Flue gas CO<sub>2</sub> commissioned value
- Flue gas CO commissioned value
- Flue gas NO commissioned value
- Flue gas NO<sub>2</sub> commissioned value (if optioned)
- Flue gas SO<sub>2</sub> commissioned value (if optioned)
- Flue gas exhaust temperature
- Ambient temperature
- Flue gas delta temperature
- EGA errors
- Chiller condition
- Current emissions by weight and volume (O<sub>2</sub>, CO, CO<sub>2</sub>, NO, SO<sub>2</sub>, H<sub>2</sub>O, N<sub>2</sub>, Total)
- Totalised emissions by weight and volume (O<sub>2</sub>, CO, CO<sub>2</sub>, NO, SO<sub>2</sub>, H<sub>2</sub>O, N<sub>2</sub>, Total)
- Heat input, heat loss and net useful heat
- Net efficiency, gross efficiency and delta temperature
- Flue flow rates, instantaneous and totalised for up to 2 years
- Fuel consumption, fuels costs instantaneous and totalised for up to 2 years

### Mini MK8 MM

- Actual boiler temperature (deg. C/F) or pressure (Bar/PSI)
- Required setpoint i.e. required boiler temperature (deg. C/F) or pressure (Bar/PSI)
- Burner on/off status
- Burner firing rate (%)
- Fuel selected
- Burner rating
- Fuel flow metering values
- Load detector type (temperature/pressure)
- Lockout and Error history
- Auto/hand/low flame hold operation
- Number of channels used
- Channel 1, 2, 3 servomotor angle
- Channel 4 output and input signals to VFD with feedback history
- Burner firing status
- Lead/lag boiler status
- Sequence order
- Sequence status (on, standby, warming, off)
- Enabled/disabled status
- Total hours run
- Number of start-ups per fuel

### 1.3. Dimensions and Fixing

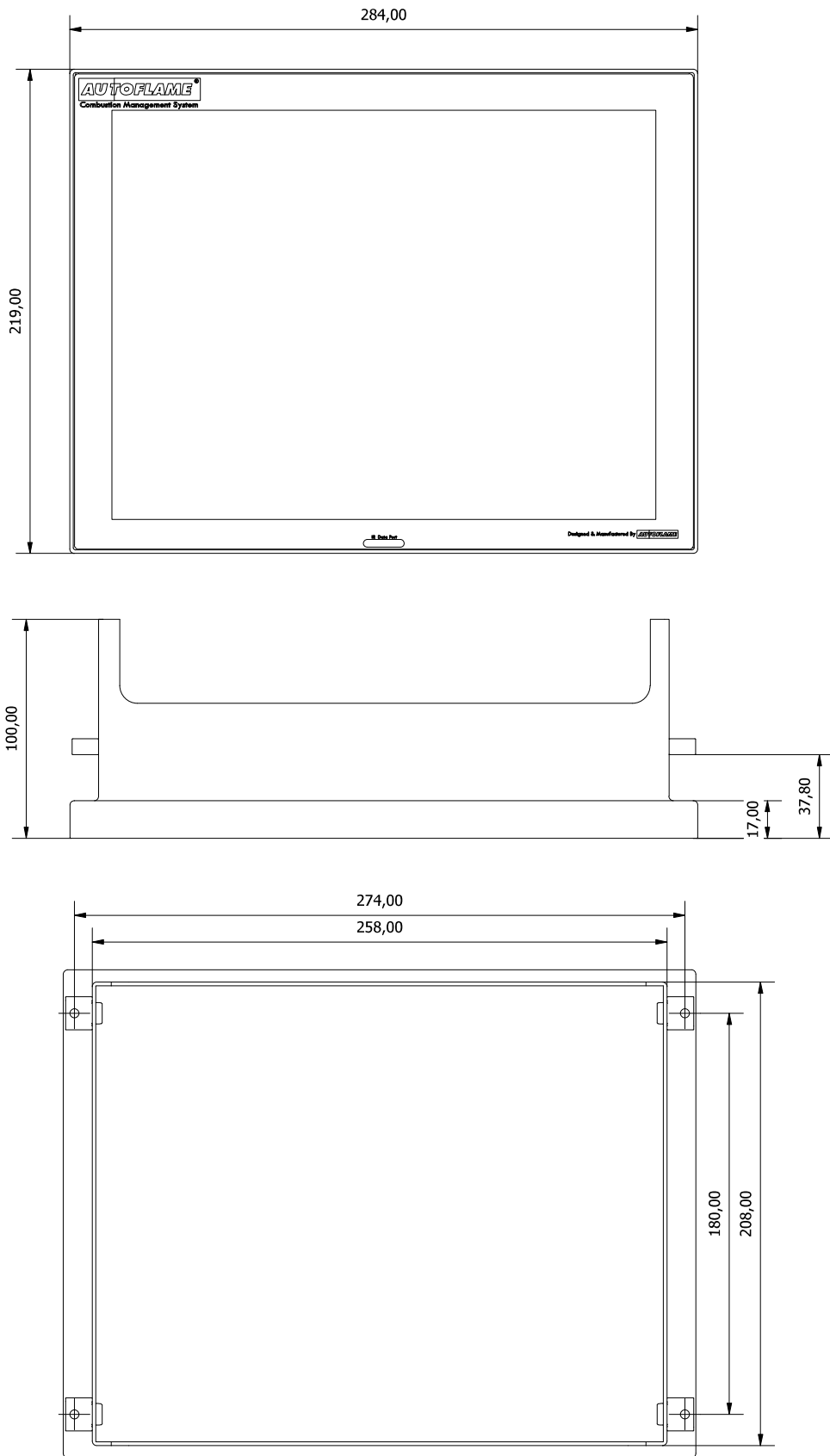

Panel Cut-out: 260 x 210

All dimensions in mm. 1 inch = 2.54mm

## 1.4. Specifications

### 1.4.1. General Specifications

Specifications	
Mains Supply Rated Voltage	110/230 V AC
Mains Supply Rated Current	0.5 A
Alarm Relay Contacts (NC/C/NO) Rated Voltage	250 V AC
Alarm Relay Contacts (NC/C/NO) Rated Current	8 A
Pressure Sensor Power Output (P+/ P-) Rated Voltage	12 V DC
Pressure Sensor Power Output (P+/ P-) Max. Current	0.5 A
Max. Temperature	60°C (140°F)
Recommended Temperature	< 40°C (104°F)
Dimensions (LxWxD)	284x219x100 mm

### 1.4.2. Fuses

Fuse #	Rating	Description
Fuse 1	500 mA	Protects Mains input to the DTI
Fuse 2	500 mA	Protects the 12v power supply to the gas/air pressure sensors

### 1.4.3. Cables

#### Low Voltage

The screened cable used for low voltage wiring from the DTI to the Pressure Sensors must conform to the following specification:

- 16/0.2mm PVC insulated overall braid, screened, PVC sheathed

Use the number of cores suitable for the application. A universal part numbering system appears to have been adopted for this type of cable as follows:

- 16-2-2C 2 Core
- 16-2-4C 4 Core

#### Data Cable

Data cable must be used for communication connections between the MMs for sequencing applications as well as between MMs to EGAs, MMs to a DTI, I/O Modules to DTI and DTI to BMS systems. Communication cable should not exceed 1000 metre in length.

Types of data cable that can be used:

- Belden 9501 for 2-core shielded cable (1 twisted pair)
- Belden 9502 for 4-core shielded cable (2 twisted pairs)
- STC OS1P24

## 2. MK8 DTI SETUP

### 2.1. Mk8 DTI Wiring

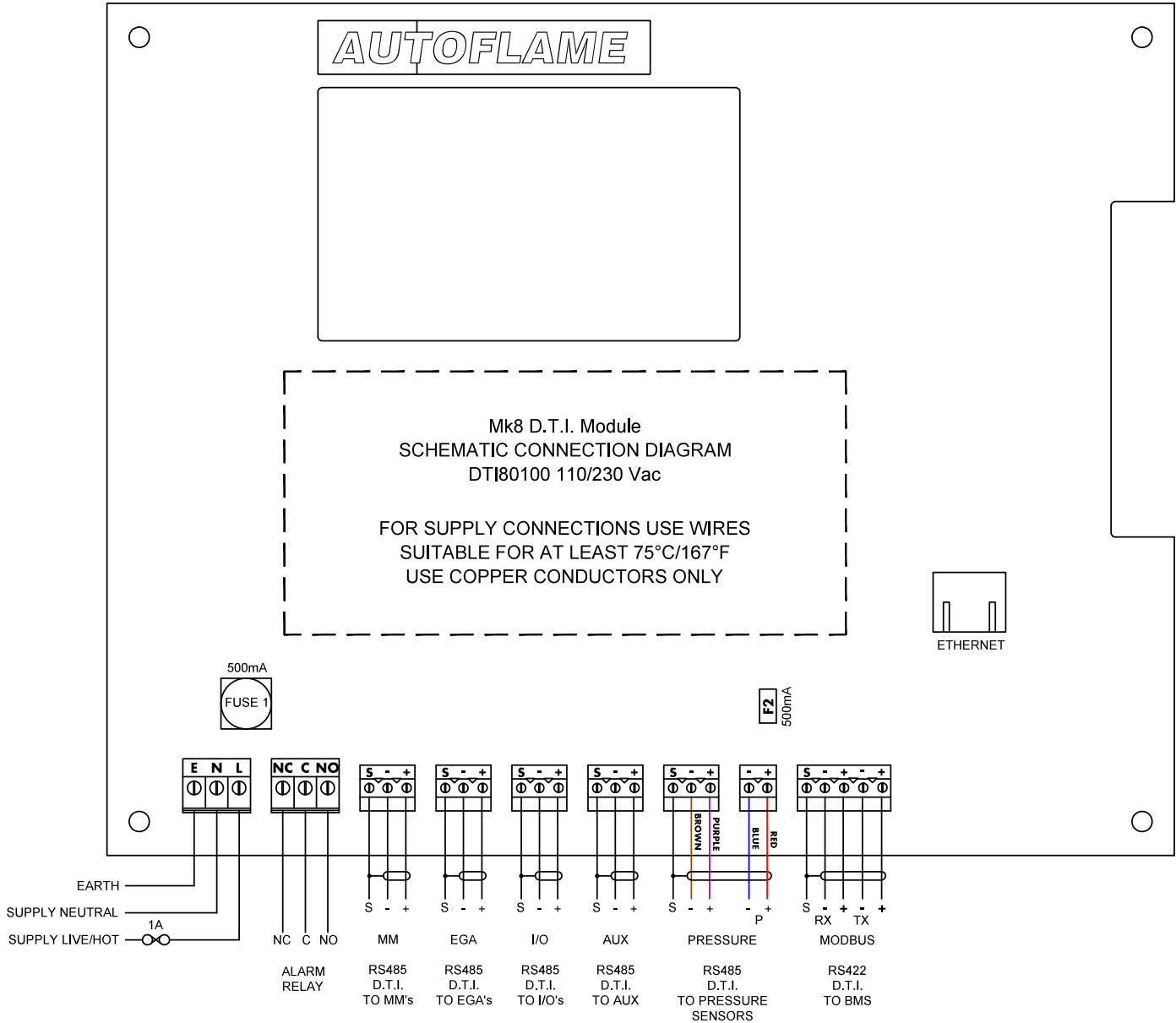

## 2.2. System Schematic

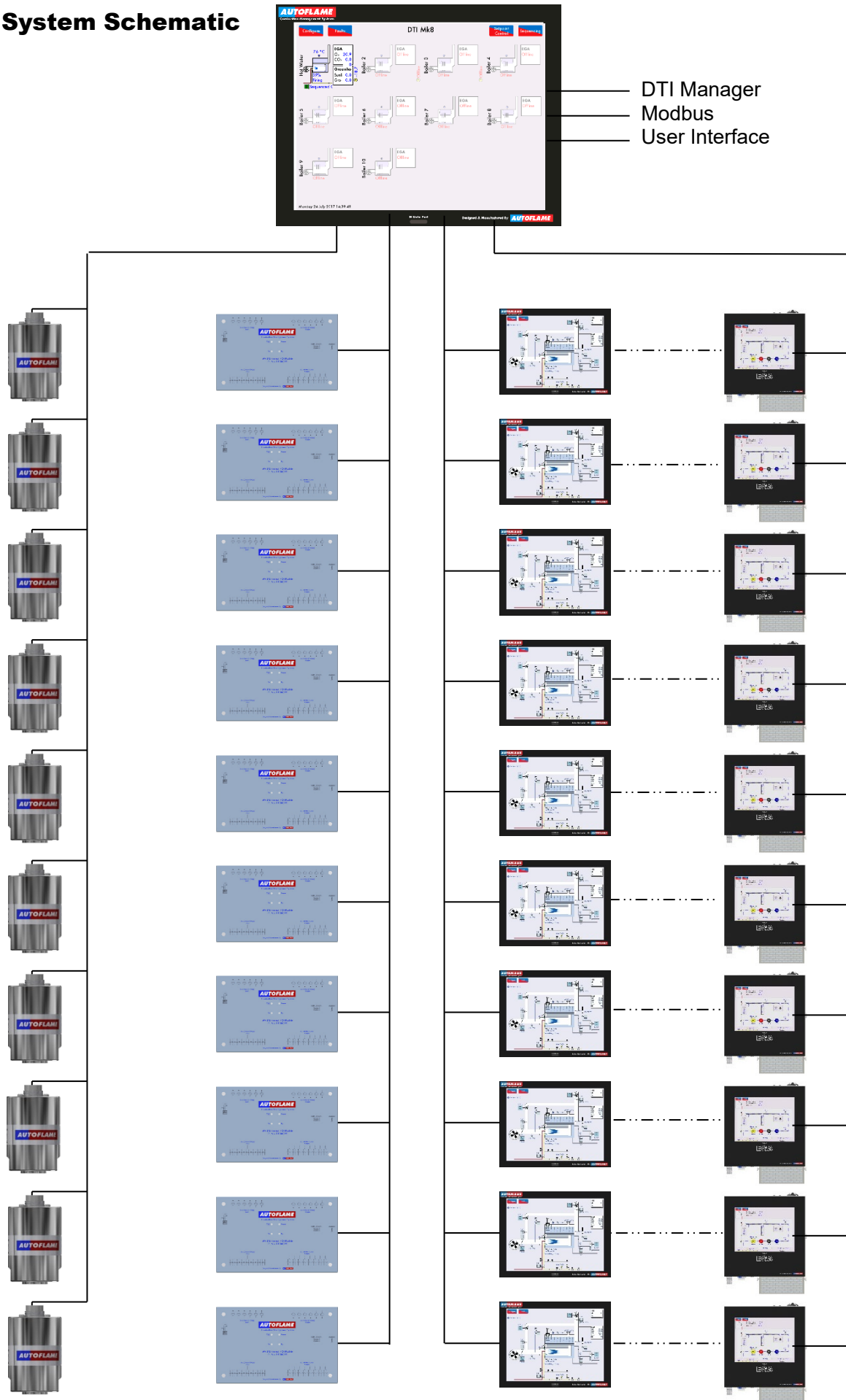

### 2.3. MK8 MM and MK8 EGA EVO with MK8 DTI

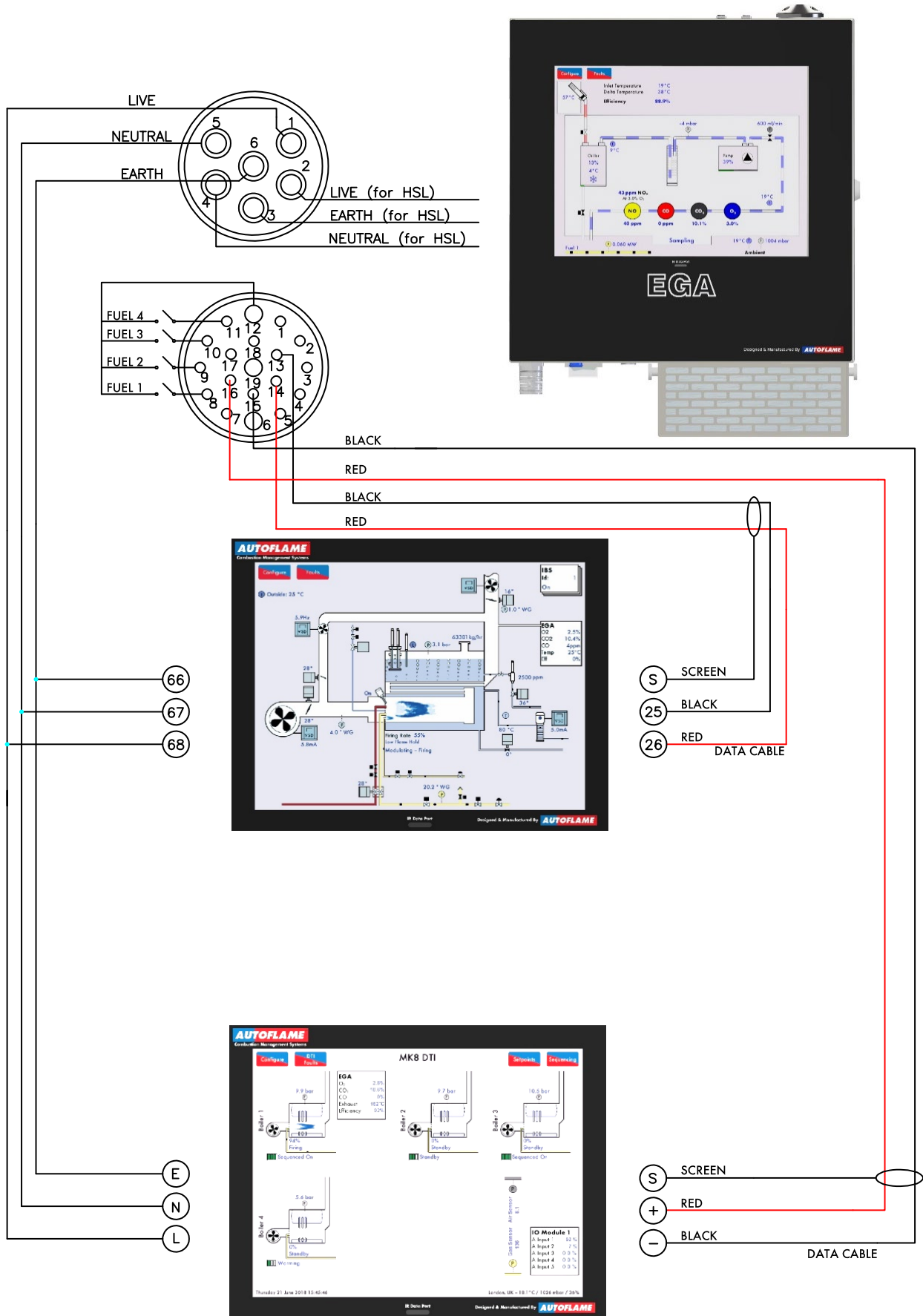

## 2.4. Mk8 Gas/Air Pressure Sensors with Mk8 DTI

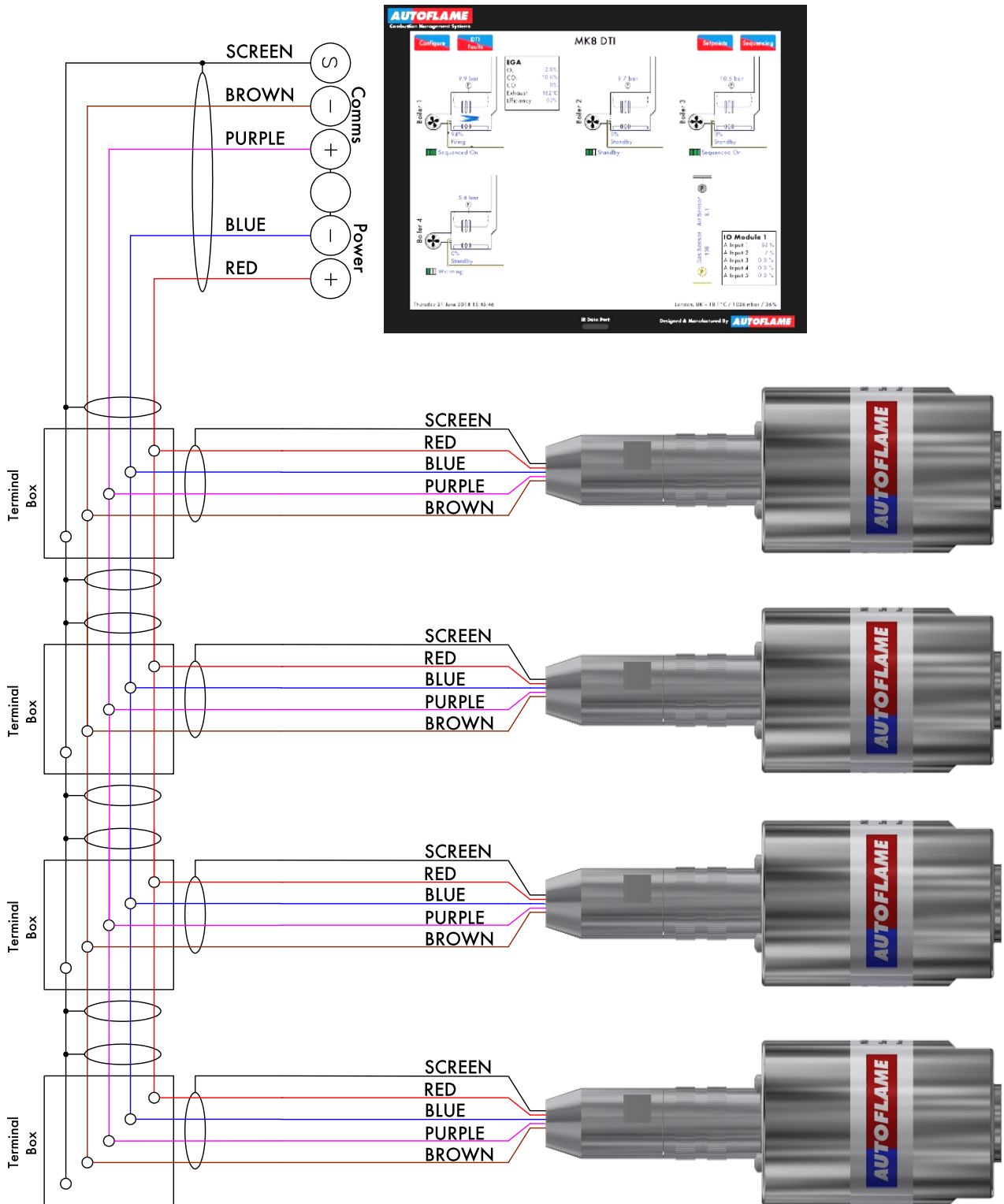

When connecting a single sensor directly to the DTI, do not connect the screen to the DTI terminal as the supplied flying lead has the screen made at the sensor side. When more than one sensor is going to be connected to the DTI or when the sensor is connected through a junction box, each sensor's flying lead has the screen made at the sensor side. The individual screens **must not** be connected together as this will generate an Earth Fault Loop which will affect the correct operation of the sensors. If using an extension length of cable from the DTI to a terminal block that connects to the sensors, the screen of the extension cables should be made at the DTI end only.

## 2.5. Configuring the DTI

When the MK8 DTI is powered up for the first time an empty boiler room is presented. At this stage the DTI needs to be configured.

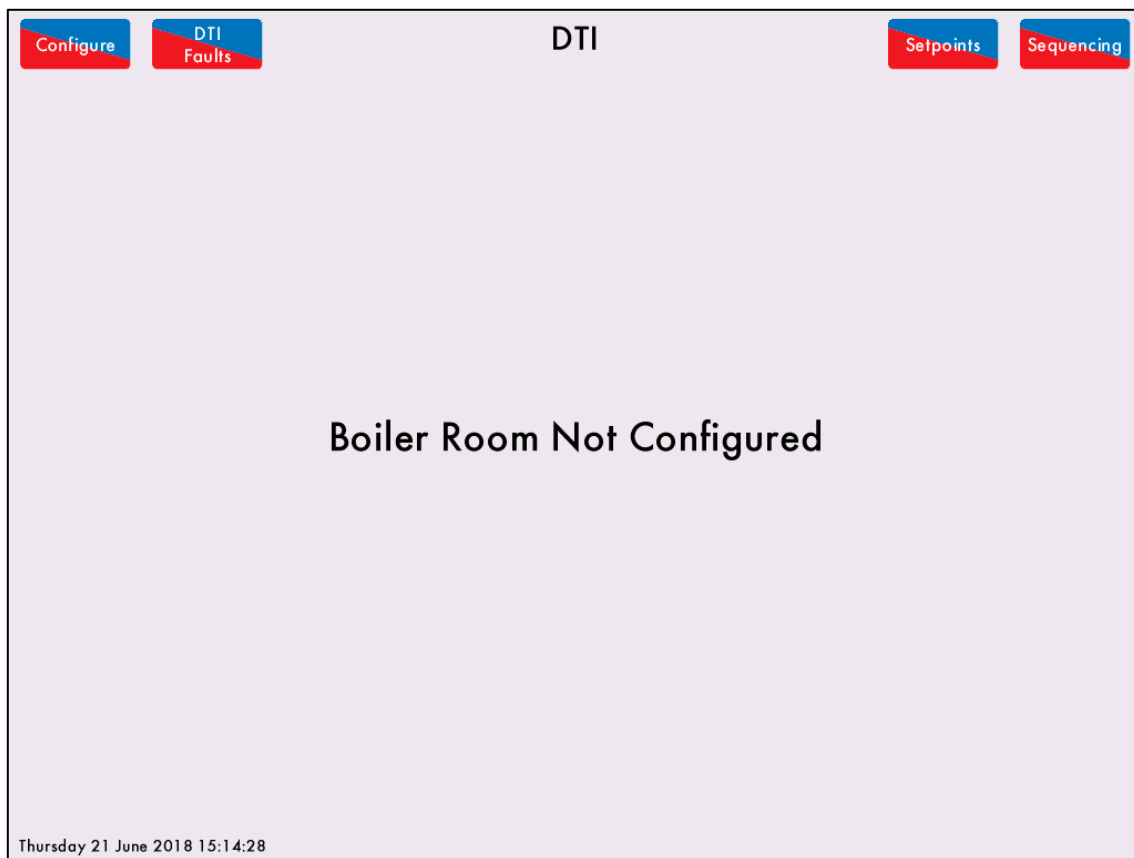



Figure 2.2.i: Mk8 DTI home screen before configuration

To access the configurations screen, press the  button in the top left hand corner of the screen. The System configuration screen should now show as in the following figure.

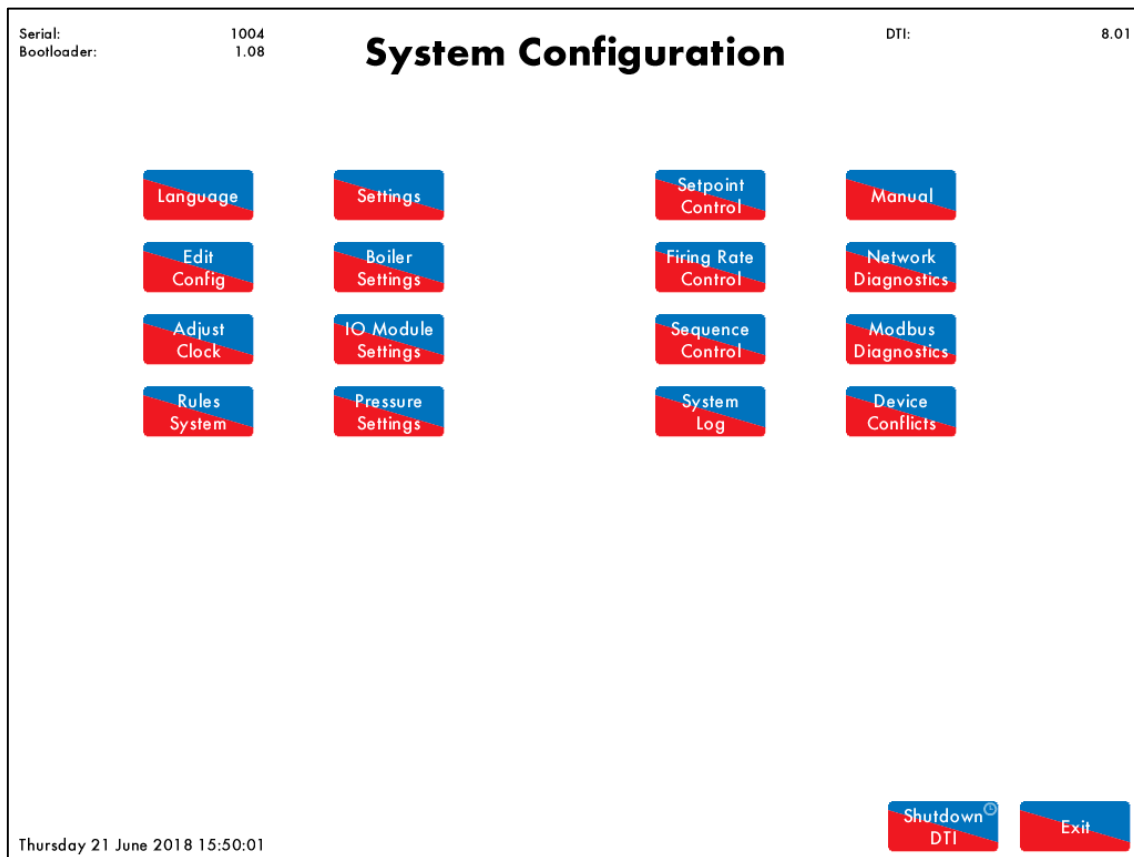

Figure 2.2.ii: System Configuration Screen

The System Configuration screen provides the following information:

- Serial Number
- Bootloader version
- DTI software version

Via the System Configurations screen, the following screens can be accessed:

- Language selection
- Edit Configurations
- Adjust clock
- Rules System – view only
- Settings – view only
- Boiler settings – view only
- IO Module settings – view only
- Pressure settings – view only
- Setpoint control
- Firing rate control
- Sequence control
- System log
- Manuals
- Network Diagnostics
- Modbus diagnostics
- Device conflicts



This screen also allows performing a safe shutdown or restart of the DTI by pressing the **Shutdown DTI** button. In order to avoid any loss of data this button should always be used before powering down the panel.



To configure the DTI, press the **Edit Config** button in the System Configuration. The following Configuration password screen will be presented. Enter the Configure password. The default Configure password is the same as the default Commission password for a MM. Use the key pad to enter the password. Type the password's "Code1" and press enter, then type the password's "Code 2" and press enter again.



Then press the **Continue** button to move on to the next screen. If the password is invalid, press on



or



**Code 2** button to change the value of the incorrect entry.

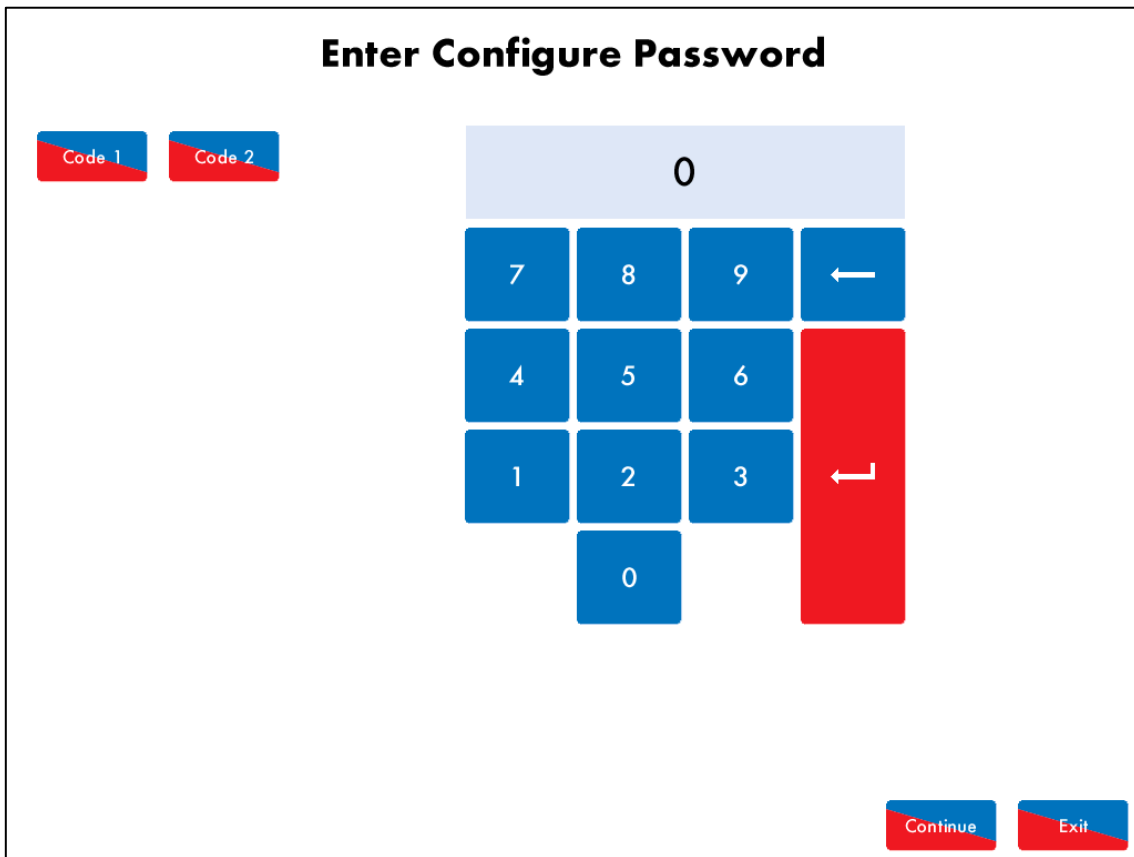

Figure 2.2.iii: Configuration Password Screen

Once the password has been entered the DTI can be configured and the Edit configuration screen is presented.

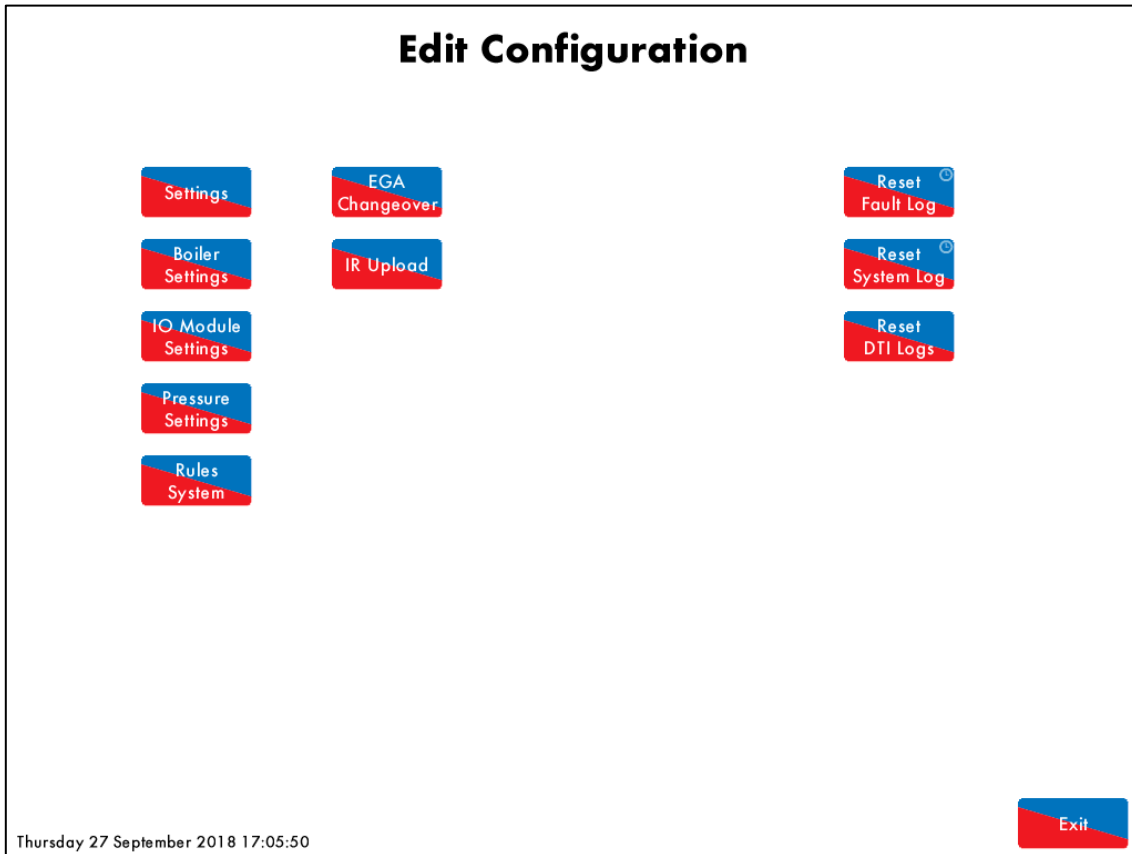





Figure 2.2.iv: Edit Configuration Screen

The Edit Configuration screen allows to:

- Access DTI's settings
- Access Boiler's settings
- Access I/O Module's settings
- Access Pressure Sensor's settings
- Access Rules System
- Access EGA Changeover screen
- Access IR Upload screen
- Perform a Fault Log reset
- Perform a System Log reset
- Perform a DTI Logs reset

Editing Settings		
#	Description	Value
1	DTI: DTI Name	DTI
2	DTI: Configuration Password 1	***
3	DTI: Configuration Password 2	***
4	DTI: Control Password 1	***
5	DTI: Control Password 2	***
6	DTI: Date Format	Day/Month/Year
7	DTI: Time Format	24 Hour
8	DTI: Display Units	Metric Units
9	DTI: Bluetooth Enabled	Enabled
10	DTI: Outside Temperature Service	Disabled
11	DTI: Alarm Output Mode	Errors and warnings
12	Unused: Unused	0
13	Unused: Unused	0
14	Unused: Unused	0
15	Unused: Unused	0
16	Unused: Unused	0
17	Unused: Unused	0
18	Unused: Unused	0
19	Unused: Unused	0

All
DTI
Modbus
Network
Email
Boiler

Monday 25 June 2018 10:39:46

Figure 2.2.v: DTI Settings



To access the DTI’s own settings screen, press  in the Edit Configuration screen. Any number of options can be changed at one time. By pressing DTI, Modbus, Network, Email or Boiler at the bottom of the screen, the options can be grouped together by feature.

#	Default	Range	Description
1	DTI		<u>DTI Name</u> Specify a name for the DTI
2	***	0 – 255	<u>Configuration Password 1</u> Code 1
3	***	0 – 255	<u>Configurations Password 2</u> Code 2
4	***	0 – 255	<u>Control Password 1</u> Code 1
5	***	0 – 255	<u>Control Password 2</u> Code 2
6	0	0 1	<u>Date Format</u> Day/Month/Year Month/Day/Year
7	0	0 1	<u>Time Format</u> 24 Hour 12 Hour
8	0	0 1	<u>Display Units</u> Metric Units Imperial Units
9	1	0 1	<u>Bluetooth Enabled</u> Disabled Enabled
10	0	0 1	<u>Outside Temperature Service</u> If set to 1, DTI provides Outside Temperature information to MMs when Outside Temperature Compensation is enabled in MMs. Disabled Internet Weather Service
11	0	0 1 2	<u>Alarm Output Mode</u> Selects operation of the Alarm Output Relay. Errors and Warnings Errors only Disabled
20	0	0 1	<u>Modbus Mode</u> Selects the Modbus operation mode. For setting 0, DTI allows Read and Write commands over Modbus. For setting 1, DTI only allows Read commands Read/Write Operation Read-Only Operation
21	1	1 – 254	<u>Modbus Address</u> Selects DTI Modbus ID address for multiple device Modbus communication line.
22	0	0 1	<u>Modbus Serial Format</u> The Serial Format should be set the same as the Serial Format used on the external Modbus communication program. Binary (RTU) Mode ASCII Mode

#	Default	Range	Description
23	1	0 1	<u>Modbus Serial Baud Rate</u> The baud rate on the DTI should be set the same as the baud rate used on the external Modbus communication program. 9600 19200
24	0	0 1	<u>Modbus Serial Parity</u> The Modbus parity on the DTI should be set the same as the parity used on the external Modbus communication program. Even Parity (1 Stop Bit) No Parity (2 Stop Bits)
25	0	0 1 2	<u>Modbus TCP access control</u> For setting 0, DTI allows any device to connect over Modbus. For setting 1, DTI only allows access over Modbus from devices connected to the same local network. For setting 2, DTI only allows the IP address specified in option 26 to connect over Modbus. Unrestricted Local subnet only Single IP address only
26	0.0.0.0		<u>Modbus TCP single IP address</u> If option 25 is set to 2, this option specifies the single IP address the DTI allow to connect over Modbus.
40	0.0.0.0		<u>IPV4 Address</u> If DHCP is disabled in option 43, an IP address needs to be manually specified to identify the DTI in a Network.
41	0.0.0.0		<u>IPV4 Subnet Mask</u> If DHCP is disabled in option 43, the IP address of the network the DTI is meant to connect to needs to be manually specified for a Network Connection.
42	0.0.0.0		<u>IPV4 Default Gateway</u> If DHCP is disabled in option 43, the IP address of the Server/Router providing an external connection needs to be manually specified for a Network connection.
43	1	0 1	<u>DHCP Enabled</u> For Setting 0, options 40 to 42 need to be manually set to establish a network connection. For setting 1, the DTI obtains an IP address, subnet mask and default gateway from the DHCP server or configured router. DHCP Disabled DHCP Enabled
44	0	0 1	<u>IPV4 DNS Mode</u> For setting 0, the IP addresses of both the primary and secondary DNS servers are automatically obtained. For setting 1, the IP addresses of both the primary and secondary DNS servers need to be manually specified. Obtain DNS Servers Automatically Specify DNS Servers Manually
45	0.0.0.0		<u>IPV4 Primary DNS Server</u> If option 44 is set to 1, the IP address of the Primary DNS server on the network needs to be manually specified.

#	Default	Range	Description
46	0.0.0.0		<u>IPv4 Secondary DNS Server</u> If option 44 is set to 1, the IP address of the Secondary DNS server on the network needs to be manually specified.
47	DTI		<u>Network Name</u> The DTI's Network Name allows a label to be given for the DTI on the network it sits on.
50	1	0 1	<u>Network Time Enabled</u> If set to 1, the DTI obtains time and date from the network time server specified in option 51. Network Time Disabled Network Time Enabled
51	-		<u>Network Time Server</u> If option 50 is set to 1, the Time server name needs to be specified
52	0	-22 – 28	<u>Network Time UTC Offset</u> The Network Time UTC offset is an offset from the Coordinated Universal Time (UTC) to adjust to local time.
53	502	0 – 65535	<u>Modbus Port</u>
54	80	0 – 65535	<u>Remote Client Port</u> Webserver port used to remotely connect to the DTI.
55	0	0 1 2	<u>Weather Service</u> Disabled Open Weather Map APIXU
56	London UK		<u>Weather Location</u> If Weather service is enabled in option 55, specify location
57	0		<u>Monitoring Service</u> Monitoring Service Functionality not available in first release
58	-		<u>Remote Client Password</u> DTI request this password to allow connection to the DTI Manager software.
60	-		<u>SMTP Server Name or Address</u> Specify server name or address for Email set-up.
61	25	0 – 65535	<u>SMTP Server Port Number</u> Specify sever port number for Email set-up.
62	-		<u>SMTP Server Username</u> Specify account username
63	-		<u>SMTP Server Password</u> Specify account password
64	-		<u>DTI Email Address</u> Specify email address the DTI will use to send emails
70	-		<u>Email Address 1</u> Recipient email address 1.

#	Default	Range	Description
71	-		<u>Email Address 2</u> Recipient email address 2.
72	-		<u>Email Address 3</u> Recipient email address 3.
73	-		<u>Email Address 4</u> Recipient email address 4.
74	-		<u>Email Address 5</u> Recipient email address 5.
75	-		<u>Email Address 6</u> Recipient email address 6.
76	-		<u>Email Address 7</u> Recipient email address 7.
77	-		<u>Email Address 8</u> Recipient email address 8.
78	-		<u>Email Address 9</u> Recipient email address 9.
79	-		<u>Email Address 10</u> Recipient email address 10.
80	0	0 1 2	<u>Global Setpoint Type</u> Temperature Pressure Low Pressure
81	0	0 – 1000	<u>Global Setpoint Minimum</u> For option 80 set to '0' then value 50 = 50 <sup>0</sup> C. For option 80 set to '1', then value 50 = 5.0 bar. For option 80 set to '2', then value 50 = 0.5 bar.
82	0	0 – 1000	<u>Global Setpoint Maximum</u> For option 80 set to '0' then value 50 = 50 <sup>0</sup> C. For option 80 set to '1', then value 50 = 5.0 bar. For option 80 set to '2', then value 50 = 0.5 bar.
150	0	5	<u>Clear Configuration Data</u> Factory Reset

## 2.6. Resetting Data

### Fault Log



To clear the fault log press and hold the  button for 3 seconds. This button is available from the 'Edit Configuration' screen and the configuration password is needed to access it.

### System Log



To clear the system log press and hold the  button for 3 seconds. This button is available from the 'Edit Configuration' screen and the configuration password is needed to access it.

### DTI Logs

**Note:** This procedure clears the long term logs from the DTI's SD card.



To clear the logged data from each device connected to the DTI, press  to access the 'DTI Log

Reset' screen. Then press and hold the  button for 3 seconds. The DTI will delete all the logged data and reboot itself.



### Factory Restore

**Note:** This procedure clears the long term logs from the DTI's SD card.

To set all the options on the DTI to default and erase all the stored data, set option 150 to 5. Then press exit to go back to the 'System Configuration' screen. The DTI will perform a Factory Restore and automatically restart.

### 3. **BOILER ROOM CONFIGURATION**

#### 3.1. **MM and EGA Settings**

In order to successfully establish communications and avoid devices conflict, certain options and parameters must be properly set in the Mk8 MMs and Mk8 EGAs EVO in the boiler room. For data logging, both MMs and EGAs must be connected directly to the DTI.

##### 3.1.1. **Mk8 MM Options and Parameters**

To get the MK8 DTI to communicate with the MK8 MM, the right communication settings must be set on the MK8 MM. The following options and parameters must be set.

#	Default	Range	Description
16	0		<b>Sequencing and DTI Enable</b> Sequencing is a system in which a number of MMs can operate together to contribute to a shared load, intelligently managing the number of MMs firing at once to maximize efficiency. DTI control allows the DTI to control some features such as adjusting setpoints, firing rates, sequence order, or disabling the MM. 0 Sequencing disabled 1 Sequencing enabled 2 DTI enabled 3 Sequencing and DTI
30	50	5 – 9990	<b>Minimum Remote Setpoint (DTI/ Modbus)</b> If a required value command is received from the DTI or Modbus that is below this minimum remote setpoint value, then it will be ignored by the MM. The MM will continue to fire to meet the previous required setpoint. °C, °F, PSI or 0.1 bar or 0.01 bar for low pressure sensor (depends on load detector set in option 1 and metric/imperial units set in parameter 40)
31	100	5 – 9990	<b>Maximum Remote Setpoint (DTI/ Modbus)</b> If a required value command is received from the DTI or Modbus that is above this maximum remote setpoint value, then it will be ignored by the MM. The MM will continue to fire to meet the previous required setpoint. °C, °F, PSI or 0.1 bar or 0.01 bar for low pressure sensor (depends on load detector set in option 1 and metric/imperial units set in parameter 40)
33	1	1 – 10	<b>MM Identification</b> Each MM within a sequencing/ DTI/ Modbus/ twin burner loop must be set with an individual ID number. For communications between the MMs, there cannot be more than 1 MM with the same ID number. ID number
57	10	1 –10	<b>Highest MM ID</b> This sets the highest MM ID number for that sequence or DTI loop. Sequence ID
101	0	0 1	<b>Shuffle Sequencing</b> This allows the sequence order to be changed remotely through the DTI or Modbus. See option 16 and expansion option 100. 0 Disabled 1 Enabled

### 3.1.2. Mini MK8 MM Options and Parameters

To get the MK8 DTI to communicate with the Mini MK8 MM, the right communication settings must be set on the Mini MK8 MM. The following options and parameters must be set.

#	Default	Range	Description
16	0		<u>Sequencing and DTI Enable</u> Sequencing is a system in which a number of MMs can operate together to contribute to a shared load, intelligently managing the number of MMs firing at once to maximize efficiency. DTI control allows the DTI to control some features such as adjusting setpoints, firing rates, sequence order, or disabling the MM. 0 Sequencing disabled 1 Sequencing enabled 2 DTI enabled 3 Sequencing and DTI
30	50	5 – 9990	<u>Minimum Remote Setpoint (DTI/ Modbus)</u> If a required value command is received from the DTI or Modbus that is below this minimum remote setpoint value, then it will be ignored by the MM. The MM will continue to fire to meet the previous required setpoint. °C, °F, PSI or 0.1 bar or 0.01 bar for low pressure sensor (depends on load detector set in option 1 and metric/imperial units set in option 65)
31	100	5 – 9990	<u>Maximum Remote Setpoint (DTI/ Modbus)</u> If a required value command is received from the DTI or Modbus that is above this maximum remote setpoint value, then it will be ignored by the MM. The MM will continue to fire to meet the previous required setpoint. °C, °F, PSI or 0.1 bar or 0.01 bar for low pressure sensor (depends on load detector set in option 1 and metric/imperial units set in option 65)
33	1	1 – 10	<u>MM Identification</u> Each MM within a sequencing/ DTI/ Modbus loop must be set with an individual ID number. For communications between the MMs, there cannot be more than 1 MM with the same ID number. ID number
100	0	0 1	<u>Sequencing/DTI or Modbus Operation</u> 0 MM/DTI Sequencing 1 Modbus
57	10	1 – 10	<u>Highest MM ID</u> This sets the highest MM ID number for that sequence or DTI loop. Sequence ID
101	0	0 1	<u>Shuffle Sequencing</u> This allows the sequence order to be changed remotely through the DTI or Modbus. See option 16 and expansion option 100. 0 Disabled 1 Enabled

### 3.1.3. MK8 EGA EVO Options

To get the MK8 DTI to communicate with the MK8 EVO EVO, the right communication settings must be set on the MK8 EGA EVO. The following setting must be set:

#	Default	Range	Description
2	1	1 – 10	<u>Communications ID</u> The ID number is used when the EGA is connected to a DTI. When multiple EGAs are connected to a DTI, each EGA will require a different ID number. Up to 10 EGAs can be connected to a DTI. ID number

### 3.2. Boiler Set-up

The MK8 DTI is a gateway for communicating with the Autoflame range of products. Through the DTI touchscreen, the boiler room can be configured with the following features:

- DTI site name
- Password protection
- Add/Remove Boiler
- Add/Remove EGAs
- Add/Remove and Edit Input/ Output Modules
- Add/Remove Pressure sensors
- Modbus Read/write ability
- Network connection setup
- Email communications setup
- Global Setpoint range and units
- Set up system rules
- Control Setpoints
- Control Firing Rates
- Control Sequence
- Restart DTI without power cycling panel power

Once the options and parameters have been set and the screened cable wired between the MMs/EGAs and the DTI, the boiler room can now be configured.



Press **Boiler Settings** in the Edit Configuration screen to enter the boilers and EGAs setup screen.

Editing Boiler Settings										
Boiler 1	Boiler 2	Boiler 3	Boiler 4	Boiler 5	Boiler 6	Boiler 7	Boiler 8	Boiler 9	Boiler 10	
#	Description									Value
1	Boiler Name									Boiler 1
2	MM Enable									Disabled
3	EGA Enable									Disabled
4	Action on MM communications failure									Generates Warning
5	Action on EGA communications failure									Generates Warning
6	Unused									0
7	Unused									0
8	Unused									0
9	Unused									0
10	Unused									0
11	Unused									0
12	Unused									0
13	Unused									0
14	Unused									0
15	Unused									0
16	Unused									0
17	Unused									0
18	Unused									0
19	Unused									0
20	Unused									0

Thursday 21 June 2018 15:00:35

Figure 3.2.i: Boiler Settings Screen

In the boiler set up screen, it can be selected whether it is a standalone DTI or if MMs are fitted. For each boiler it can also be selected if an EGA is fitted. For the MK8 DTI to receive EGA data, the EGA must be connected directly to the DTI. Any number of settings can be changed at one time. Use the tabs at the top of the display to select the desired ID number of the boiler to be configured.

When the changes have been made to suit the application's need, press Exit to save and go back to the Edit Configuration screen.

#	Default	Range	Description
1	Boiler #		<u>Boiler Name</u> Set desired name for boiler. Use on screen keyboard to type desired name.
2	0	0 1	<u>MM Enable</u> If set to 1, boiler is added to the boiler room screen. If set to 0, boiler is removed from the boiler room screen. Disabled Enabled
3	0	0 1	<u>EGA Enable</u> If set to 1, EGA is added to boiler room screen and associated to respective boiler. If set to 0, EGA is removed from the boiler room screen. The EGA must be connected direct to the DTI. Disabled Enabled
4	0	0 1	<u>Action on MM communications failure</u> For setting 0, the DTI generates a warning when communications with the respective MM are lost. For setting 1, the DTI generates an error when communications with the respective MM are lost. Generates Warning Generates Error
5	0	0 1	<u>Action on EGA communications failure</u> For setting 0, The DTI generates a warning when communications with the respective EGA are lost. For setting 1, the DTI generates an error when communications with the respective EGA are lost Generates Warning Generates Error

### 3.2.1. EGA Changeover

When an EGA establishes communications with the DTI using a certain ID number, the EGA communicates its serial number. This is used by the DTI to identify the EGA. If the EGA is replaced and a different EGA is connected to the DTI using the same ID number as the previous EGA, the DTI detects this change. When an EGA change is detected the DTI does not start logging EGA data until the user acknowledges the EGA changeover.





To confirm the change go to the System Configuration screen and then press . The Commissioning password will be needed to enter the Edit Configurations screen. Once in the Edit Configuration screen press . The following screen will be presented.



Figure 3.2.1.i: EGA Changeover Screen

The screen shown in Figure 3.2.1.i presents the EGA ID number where the EGA change has been detected. It also shows serial number of the device previously connected as well as the Serial number of the new detected device. In order to confirm the EGA change it is necessary to choose what happens with the data

logged from the previous EGA. Selecting  will make the DTI to keep the logged EGA history from the previous unit and carry on logging the data from the new EGA. Selecting  will make the DTI to delete all the history logs stored from the previous EGA and it will only keep the upcoming logs from the new EGA.

## 4. ANALOGUE AND DIGITAL INPUTS/OUTPUTS

### 4.1. MK8 Universal Input/ Output Module

#### 4.1.1. Overview

The Mk8 Universal Input / Output Module enables 3<sup>rd</sup> party additional equipment in the boiler plant to be monitored by the MK8 DTI. Each MK8 I/O unit has:

- 16 digital line inputs
- 8 volt-free contacts
- 6 analogue inputs
- 6 analogue outputs

The Mk8 I/O module is capable of totalising the input data internally, allowing the unit to run as a standalone unit. Coupled together with the Mk8 DTI, the Mk8 Universal I/O module gives detailed logging of the inputs and outputs. The Mk8 DTI can control the analogue and digital outputs, for a maximum of 10 Mk8 I/O modules. The data gathered by the Autoflame Mk8 DTI for the Mk8 I/O modules is logged for 2 years.

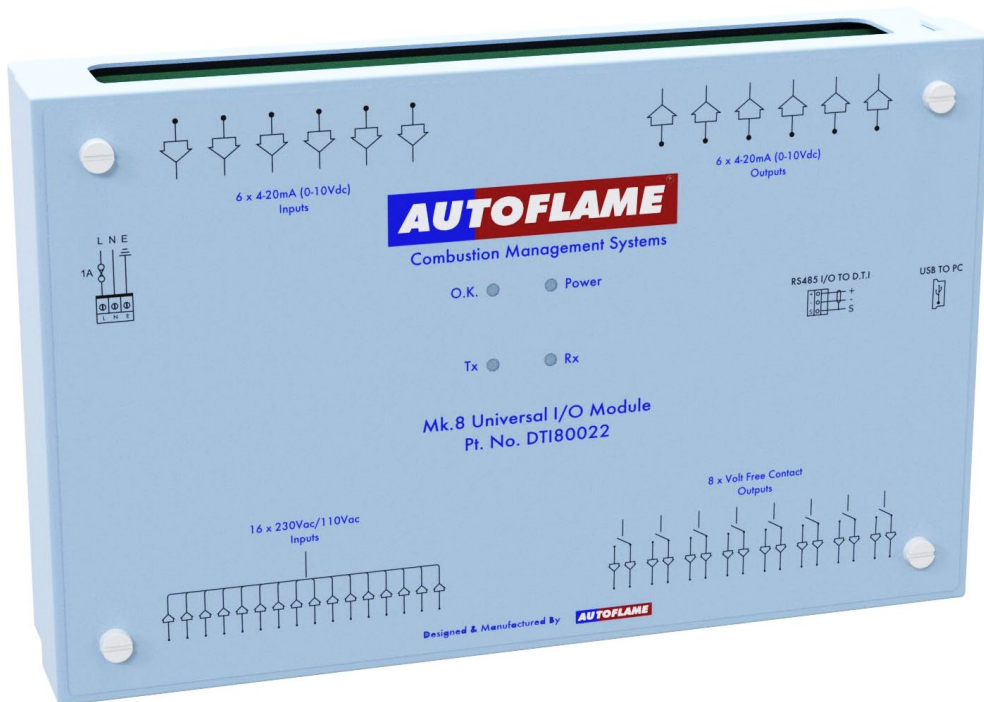

Figure 4.1.1.i: Mk8 Universal I/O Module

4.1.2. Wiring

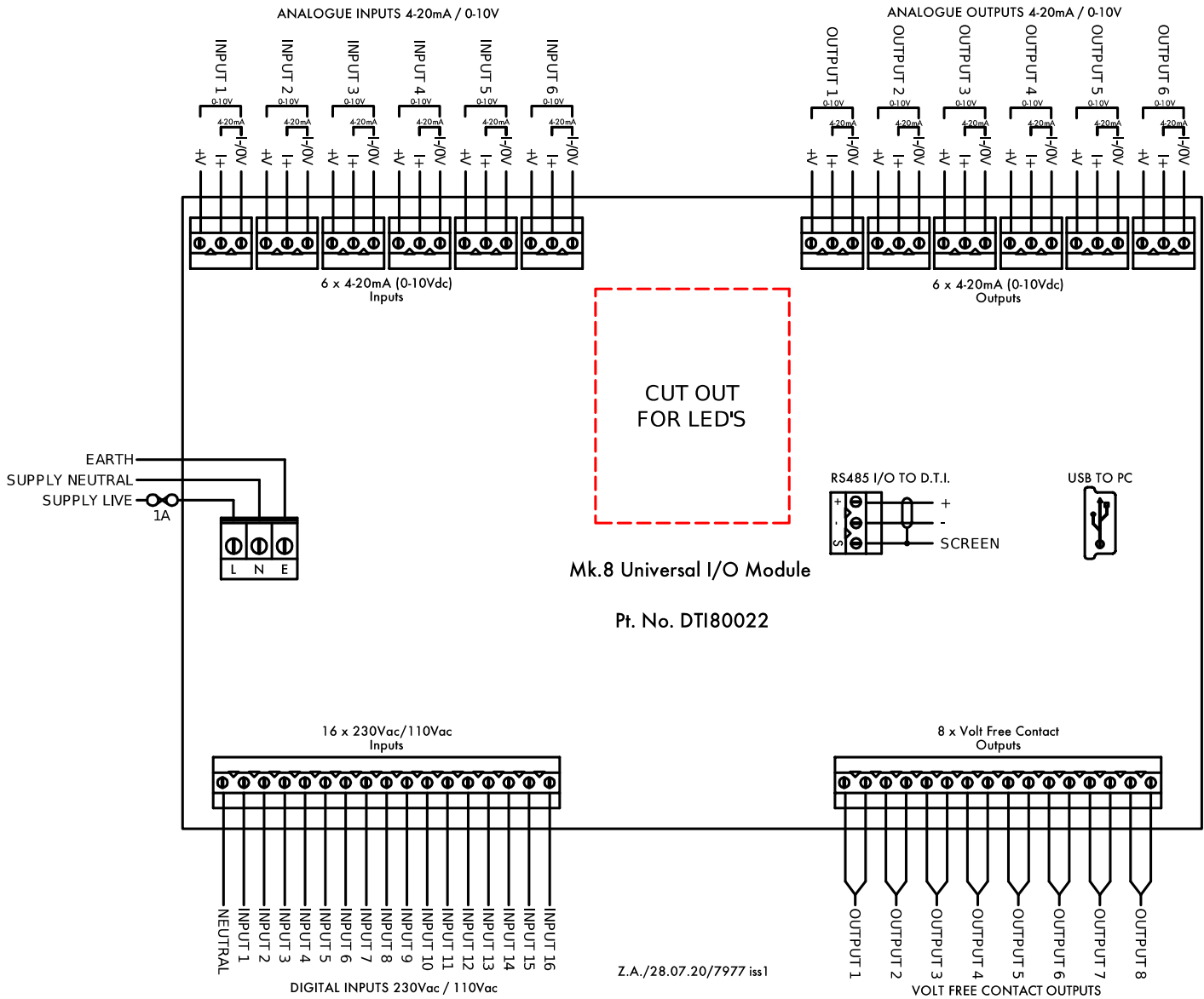

Figure 4.1.2.i: Mk8 I/O Module Wiring Schematic

### 4.1.3. Dimensions & Fixing

The IO Module has 2x DIN mounting clips and can be mounted directly to a standard DIN rail.

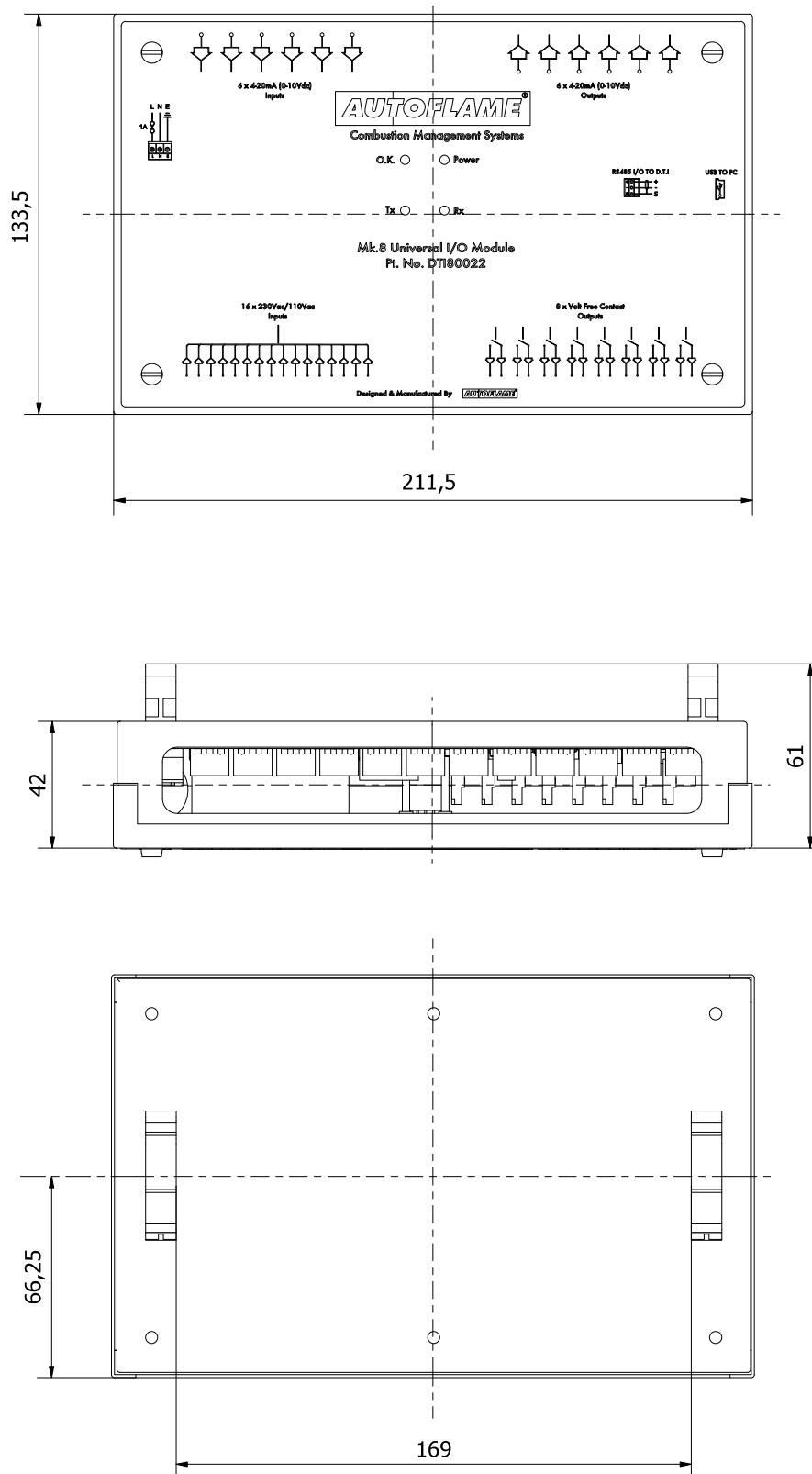

Figure 4.1.3.i: Mk8 I/O Module Dimensions

### 4.1.4. Configuring I/O Module



To enable and configure an I/O Module press  in the Edit Configuration screen to access the settings screen for the I/O Modules.



Editing IO Module Settings									
IO Module 1	IO Module 2	IO Module 3	IO Module 4	IO Module 5	IO Module 6	IO Module 7	IO Module 8	IO Module 9	IO Module 10
#	Description	Value							
1	IO Module: IO Module Enabled	Disabled							
2	IO Module: Module Name	IO Module 1							
3	IO Module: Action on Communications Failure	Generates Warning							
4	IO Module: Associate with Boiler	Independent							
5	Digital Input: Digital Input Count	16							
6	Digital Input: Digital Input 1 Name	Digital Input 1							
7	Digital Input: Digital Input 2 Name	Digital Input 2							
8	Digital Input: Digital Input 3 Name	Digital Input 3							
9	Digital Input: Digital Input 4 Name	Digital Input 4							
10	Digital Input: Digital Input 5 Name	Digital Input 5							
11	Digital Input: Digital Input 6 Name	Digital Input 6							
12	Digital Input: Digital Input 7 Name	Digital Input 7							
13	Digital Input: Digital Input 8 Name	Digital Input 8							
14	Digital Input: Digital Input 9 Name	Digital Input 9							
15	Digital Input: Digital Input 10 Name	Digital Input 10							
16	Digital Input: Digital Input 11 Name	Digital Input 11							
17	Digital Input: Digital Input 12 Name	Digital Input 12							
18	Digital Input: Digital Input 13 Name	Digital Input 13							
19	Digital Input: Digital Input 14 Name	Digital Input 14							
20	Digital Input: Digital Input 15 Name	Digital Input 15							
All	IO Module	Digital Input	Digital Output	Analogue Input	Analogue Output	  			
Thursday 21 June 2018 15:01:34									

Figure 4.1.4.i: IO Module settings screen

The Mk8 DTI is capable of communicating with up to 10 Universal Input/ Output Modules. Use the tabs at the top of the display to select the I/O Module to be set-up. By pressing IO Module, Digital Input, Digital Output, Analogue Input or Analogue Output at the bottom of the display, the options can be grouped together by feature. Any number of options can be changed at any time.

The options available for each I/O module allow individually naming of each module, setting them as independent or associating them with boilers and select the DTI's action on a communications failure. It is possible to specify how many analogue/digital inputs and outputs are being used. Setting this according to the application's requirements will make the DTI to only monitor and store the data of the relevant inputs and outputs being used. It is also possible to individually name each input and output and customize the Analogue inputs and outputs to represent specific measurement units and ranges, and specify if it is a rate (i.e. flow of a fluid).

When the changes have been made to suit the application's needs, press Exit to save and go back to the Edit Configuration screen.

#	Default	Range	Description
1	0	0 1	<u>IO Module Enabled</u> Disabled Enabled
2			<u>Module Name</u>
3	0	0 1	<u>Action on Communications Failure</u> Generates Warning Generates Error
4	0	0 – 10	<u>Associate with Boiler</u> Select ID of the boiler the IO Module is to be associated with.
5	16	0 – 16	<u>Digital Input Count</u> Specifies total number of Digital Inputs being used. For example, if 5 is selected, only 5 Digital inputs will be recorded and shown when accessing the Module's screen.
6			<u>Digital Input 1 Name</u>
7			<u>Digital Input 2 Name</u>
8			<u>Digital Input 3 Name</u>
9			<u>Digital Input 4 Name</u>
10			<u>Digital Input 5 Name</u>
11			<u>Digital Input 6 Name</u>
12			<u>Digital Input 7 Name</u>
13			<u>Digital Input 8 Name</u>
14			<u>Digital Input 9 Name</u>
15			<u>Digital Input 10 Name</u>
16			<u>Digital Input 11 Name</u>
17			<u>Digital Input 12 Name</u>
18			<u>Digital Input 13 Name</u>
19			<u>Digital Input 14 Name</u>
20			<u>Digital Input 15 Name</u>
21			<u>Digital Input 16 Name</u>
22	8	0 – 8	<u>Digital Output Count</u> Specifies total number of Digital Outputs being used. For example, if 5 is selected, only 5 Digital Outputs will be recorded and shown when accessing the Module's screen.
23			<u>Digital Output 1 Name</u>
24			<u>Digital Output 2 Name</u>

#	Default	Range	Description
25			<u>Digital Output 3 Name</u>
26			<u>Digital Output 4 Name</u>
27			<u>Digital Output 5 Name</u>
28			<u>Digital Output 6 Name</u>
29			<u>Digital Output 7 Name</u>
30			<u>Digital Output 8 Name</u>
31	6	0 – 6	<u>Analogue Input Count</u> Specifies total number of Analogue Inputs being used. For example, if 3 is selected, only 3 Analogue Inputs will be recorded and shown when accessing the Module's screen.
32			<u>Analogue Input 1 Name</u>
33	0	0 1 2	<u>Analogue Input 1 Type</u> Sets input range for analogue input 1. Voltage (0 to 10V) Current (4 to 20mA) Current (0 to 20mA)
34	1	1 – 40	<u>Analogue Input 1 Filter Length</u> Number of readings to be averaged to generate the read input values.
35	%		<u>Analogue Input 1 Units</u> Specifies desired Units to be assigned to the Analogue Input reading.
36	0	-32767 – 32768	<u>Analogue Input 1 Minimum</u> Specifies the minimum value respective to the minimum reading of the input range.
37	100	-32767 – 32768	<u>Analogue Input 1 Maximum</u> Specifies the maximum value respective to the maximum reading of the input range.
38	0	0 1 2 3 4	<u>Analogue Input 1 Rate Type</u> Set the rate type for the analogue input if the reading represents, for example, the flow of a fluid. Not a Rate Per Second Per Minute Per Hour Per Day
39			<u>Analogue Input 2 Name</u>
40	0	0 1 2	<u>Analogue Input 2 Type</u> Sets input range for analogue input 2. Voltage (0 to 10V) Current (4 to 20mA) Current (0 to 20mA)
41	1	1 – 40	<u>Analogue Input 2 Filter Length</u> Number of readings to be averaged to generate the read input values.

#	Default	Range	Description
42	%		<u>Analogue Input 2 Units</u> Specifies desired Units to be assigned to the Analogue Input reading.
43	0	-32767 – 32768	<u>Analogue Input 2 Minimum</u> Specifies the minimum value respective to the minimum reading of the input range.
44	100	-32767 – 32768	<u>Analogue Input 2 Maximum</u> Specifies the maximum value respective to the maximum reading of the input range.
45	0	0 1 2 3 4	<u>Analogue Input 2 Rate Type</u> Set the rate type for the analogue input if the reading represents, for example, the flow of a fluid. Not a Rate Per Second Per Minute Per Hour Per Day
46			<u>Analogue Input 3 Name</u>
47	0	0 1 2	<u>Analogue Input 3 Type</u> Sets input range for analogue input 3. Voltage (0 to 10V) Current (4 to 20mA) Current (0 to 20mA)
48	1	1 – 40	<u>Analogue Input 3 Filter Length</u> Number of readings to be averaged to generate the read input values.
49	%		<u>Analogue Input 3 Units</u> Specifies desired Units to be assigned to the Analogue Input reading.
50	0	-32767 – 32768	<u>Analogue Input 3 Minimum</u> Specifies the minimum value respective to the minimum reading of the input range.
51	100	-32767 – 32768	<u>Analogue Input 3 Maximum</u> Specifies the maximum value respective to the maximum reading of the input range.
52	0	0 1 2 3 4	<u>Analogue Input 3 Rate Type</u> Set the rate type for the analogue input if the reading represents, for example, the flow of a fluid. Not a Rate Per Second Per Minute Per Hour Per Day
53			<u>Analogue Input 4 Name</u>
54	0	0 1 2	<u>Analogue Input 4 Type</u> Sets input range for analogue input 4. Voltage (0 to 10V) Current (4 to 20mA) Current (0 to 20mA)

#	Default	Range	Description
55	1	1 – 40	<u>Analogue Input 4 Filter Length</u> Number of readings to be averaged to generate the read input values.
56	%		<u>Analogue Input 4 Units</u> Specifies desired Units to be assigned to the Analogue Input reading.
57	0	-32767 – 32768	<u>Analogue Input 4 Minimum</u> Specifies the minimum value respective to the minimum reading of the input range.
58	100	-32767 – 32768	<u>Analogue Input 4 Maximum</u> Specifies the maximum value respective to the maximum reading of the input range.
59	0	0 1 2 3 4	<u>Analogue Input 4 Rate Type</u> Set the rate type for the analogue input if the reading represents, for example, the flow of a fluid. Not a Rate Per Second Per Minute Per Hour Per Day
60			<u>Analogue Input 5 Name</u>
61	0	0 1 2	<u>Analogue Input 5 Type</u> Sets input range for analogue input 5. Voltage (0 to 10V) Current (4 to 20mA) Current (0 to 20mA)
62	1	1 – 40	<u>Analogue Input 5 Filter Length</u> Number of readings to be averaged to generate the read input values.
63	%		<u>Analogue Input 5 Units</u> Specifies desired Units to be assigned to the Analogue Input reading.
64	0	-32767 – 32768	<u>Analogue Input 5 Minimum</u> Specifies the minimum value respective to the minimum reading of the input range.
65	100	-32767 – 32768	<u>Analogue Input 5 Maximum</u> Specifies the maximum value respective to the maximum reading of the input range.
66	0	0 1 2 3 4	<u>Analogue Input 5 Rate Type</u> Set the rate type for the analogue input if the reading represents, for example, the flow of a fluid. Not a Rate Per Second Per Minute Per Hour Per Day
67			<u>Analogue Input 6 Name</u>

#	Default	Range	Description
68	0	0 1 2	<u>Analogue Input 6 Type</u> Sets input range for analogue input 6. Voltage (0 to 10V) Current (4 to 20mA) Current (0 to 20mA)
69	1	1 – 40	<u>Analogue Input 6 Filter Length</u> Number of readings to be averaged to generate the read input values.
70	%		<u>Analogue Input 6 Units</u> Specifies desired Units to be assigned to the Analogue Input reading.
71	0	-32767 – 32768	<u>Analogue Input 6 Minimum</u> Specifies the minimum value respective to the minimum reading of the input range.
72	100	-32767 – 32768	<u>Analogue Input 6 Maximum</u> Specifies the maximum value respective to the maximum reading of the input range.
73	0	0 1 2 3 4	<u>Analogue Input 6 Rate Type</u> Set the rate type for the analogue input if the reading represents, for example, the flow of a fluid. Not a Rate Per Second Per Minute Per Hour Per Day
74	6	0 – 6	<u>Analogue Output Count</u> Specifies total number of Analogue Outputs being used. For example, if 3 is selected, only 3 Analogue Outputs will be recorded and shown when accessing the Module's screen.
75			<u>Analogue Output 1 Name</u>
76	0	0 1	<u>Analogue Output 1 Type</u> Sets Output Range for analogue output 1. 0 to 10V or 0 to 20mA 2 to 10 V or 4 to 20mA
77	%		<u>Analogue Output 1 Units</u> Specifies desired Units to be assigned to the Analogue Output value.
78	0	-32767 – 32768	<u>Analogue Output 1 Minimum</u> Specifies the minimum value respective to the minimum output range value.
79	100	-32767 – 32768	<u>Analogue Output 1 Maximum</u> Specifies the maximum value respective to the maximum output range value.

#	Default	Range	Description
80	0		<u>Analogue Output 1 Rate Type</u> Set the rate type for the analogue output if the value represents, for example, the flow of a fluid. 0 Not a Rate 1 Per Second 2 Per Minute 3 Per Hour 4 Per Day
81			<u>Analogue Output 2 Name</u>
82	0		<u>Analogue Output 2 Type</u> Sets Output Range for analogue output 2. 0 0 to 10V or 0 to 20mA 1 2 to 10 V or 4 to 20mA
83	%		<u>Analogue Output 2 Units</u> Specifies desired Units to be assigned to the Analogue Output value.
84	0	-32767 – 32768	<u>Analogue Output 2 Minimum</u> Specifies the minimum value respective to the minimum output range value.
85	100	-32767 – 32768	<u>Analogue Output 2 Maximum</u> Specifies the maximum value respective to the maximum output range value.
86	0		<u>Analogue Output 2 Rate Type</u> Set the rate type for the analogue output if the value represents, for example, the flow of a fluid. 0 Not a Rate 1 Per Second 2 Per Minute 3 Per Hour 4 Per Day
87			<u>Analogue Output 3 Name</u>
88	0		<u>Analogue Output 3 Type</u> Sets Output Range for analogue output 3. 0 0 to 10V or 0 to 20mA 1 2 to 10 V or 4 to 20mA
89	%		<u>Analogue Output 3 Units</u> Specifies desired Units to be assigned to the Analogue Output value.
90	0	-32767 – 32768	<u>Analogue Output 3 Minimum</u> Specifies the minimum value respective to the minimum output range value.
91	100	-32767 – 32768	<u>Analogue Output 3 Maximum</u> Specifies the maximum value respective to the maximum output range value.

#	Default	Range	Description
92	0		<u>Analogue Output 3 Rate Type</u> Set the rate type for the analogue output if the value represents, for example, the flow of a fluid. 0 Not a Rate 1 Per Second 2 Per Minute 3 Per Hour 4 Per Day
93			<u>Analogue Output 4 Name</u>
94	0		<u>Analogue Output 4 Type</u> Sets Output Range for analogue output 4. 0 0 to 10V or 0 to 20mA 1 2 to 10 V or 4 to 20mA
95	%		<u>Analogue Output 4 Units</u> Specifies desired Units to be assigned to the Analogue Output value.
96	0	-32767 – 32768	<u>Analogue Output 4 Minimum</u> Specifies the minimum value respective to the minimum output range value.
97	100	-32767 – 32768	<u>Analogue Output 4 Maximum</u> Specifies the maximum value respective to the maximum output range value.
98	0		<u>Analogue Output 4 Rate Type</u> Set the rate type for the analogue output if the value represents, for example, the flow of a fluid. 0 Not a Rate 1 Per Second 2 Per Minute 3 Per Hour 4 Per Day
99			<u>Analogue Output 5 Name</u>
100	0		<u>Analogue Output 5 Type</u> Sets Output Range for analogue output 5. 0 0 to 10V or 0 to 20mA 1 2 to 10 V or 4 to 20mA
101	%		<u>Analogue Output 5 Units</u> Specifies desired Units to be assigned to the Analogue Output value.
102	0	-32767 – 32768	<u>Analogue Output 5 Minimum</u> Specifies the minimum value respective to the minimum output range value.
103	100	-32767 – 32768	<u>Analogue Output 5 Maximum</u> Specifies the maximum value respective to the maximum output range value.

#	Default	Range	Description
104	0		<u>Analogue Output 5 Rate Type</u> Set the rate type for the analogue output if the value represents, for example, the flow of a fluid. 0 Not a Rate 1 Per Second 2 Per Minute 3 Per Hour 4 Per Day
105			<u>Analogue Output 6 Name</u>
106	0		<u>Analogue Output 6 Type</u> Sets Output Range for analogue output 6. 0 0 to 10V or 0 to 20mA 1 2 to 10 V or 4 to 20mA
107	%		<u>Analogue Output 6 Units</u> Specifies desired Units to be assigned to the Analogue Output value.
108	0	-32767 – 32768	<u>Analogue Output 6 Minimum</u> Specifies the minimum value respective to the minimum output range value.
109	100	-32767 – 32768	<u>Analogue Output 6 Maximum</u> Specifies the maximum value respective to the maximum output range value.
110	0		<u>Analogue Output 6 Rate Type</u> Set the rate type for the analogue output if the value represents, for example, the flow of a fluid. 0 Not a Rate 1 Per Second 2 Per Minute 3 Per Hour 4 Per Day

## 4.2. Input / Outputs Data

The Mk8 DTI allows to view the status of the inputs and outputs for each I/O Module. To access this information press the IO Module animation in the DTI's home screen.

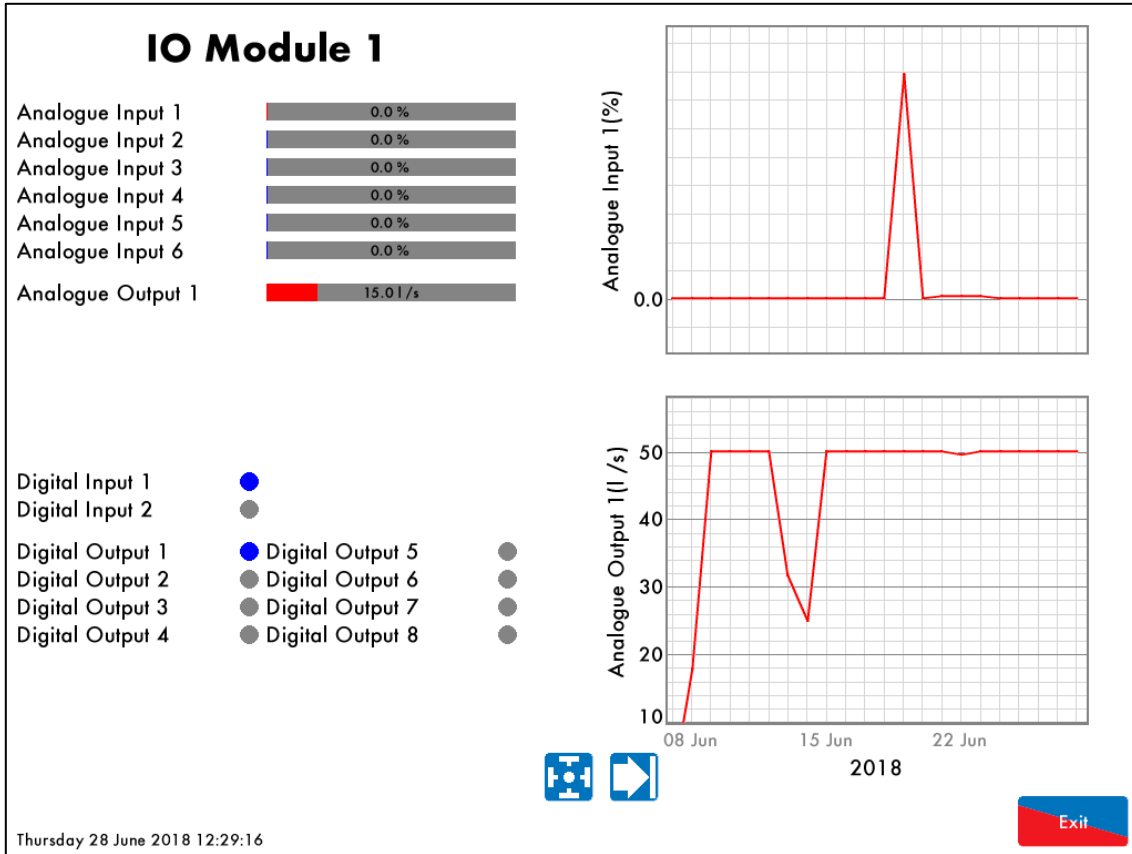

Figure 4.2.i: IO Module Screen

The I/O module screen displays the status of all the inputs and outputs both analogue and digital. Only the inputs and outputs enabled via the input/output count are drawn on the display. This screen also provides history graphs for the analogue inputs and outputs. Each time this screen is accessed, by default, the history graphs of the first 2 analogue values are selected. To view the history of any other analogue input or output, simply touch the screen on top of the desired input or output to be seen.



This data is logged for 2 years on the DTI. Use the   buttons to change the timescale of the data displayed, and press and drag on the axis to zoom in/out of the graph.

The totalised analogue input rates are available on Modbus. See section 9 for the respective Modbus addresses.

## 5. **PRESSURE SENSORS**

### 5.1. **MK8 Gas/Air Pressure Sensor**





The Mk8 DTI allows monitoring gas and air pressure throughout the boiler house. Up to ten Mk8 gas pressure sensors, Mk8 air pressure sensors or any combination of both can be connected to the DTI. The DTI stores 2 years of pressure readings data. Live readings can be seen via the DTI's display as well as the logged history data.



*Figure 5.1.i: Gas / Air Pressure Sensor*

Via the DTI's configuration options for each pressure sensor connected it is possible to set high and low pressure limits. The DTI can also be set to generate warnings or errors when the pressure readings go outside the limits. The gas and air pressure sensors compatible with the Mk8 DTI are specified below.

#### Gas / Air Sensor Wiring:

Wire Colour		Mk8 DTI Terminal
Brown		RS485 -
Purple		RS485 +
Blue		15V DC +
Red		15V DC -
Black		S

Please refer to AutoFlame's Sensors Guide for further information about gas and air pressure sensors.

## 5.2. Configuring Pressure Sensor

To enable and configure a pressure sensor press



in the Edit Configuration screen to access the settings screen for the Pressure Sensors.

Configured Sensors		
Name	Type	Reading
1. Disabled		
2. Disabled		
3. Disabled		
4. Disabled		
5. Disabled		
6. Disabled		
7. Disabled		
8. Disabled		
9. Disabled		
10. Disabled		

Thursday 28 June 2018 12:24:20

A rectangular button with a blue top half and a red bottom half. The text "Exit" is written in white on the red background.

Figure 5.2.i: Configured Sensors Screen

Initially no sensors are configured and the display will show as above. When new sensors are connected, the

DTI will automatically detect the new sensor. Pressing the



button will automatically configure the detected sensor and add it to the configured sensors list.



### Configured Sensors

Name	Type	Reading
1. Disabled		
2. Disabled		
3. Disabled		
4. Disabled		
5. Disabled		
6. Disabled		
7. Disabled		
8. Disabled		
9. Disabled		
10. Disabled		

### New Sensor

MM80006 Gas Sensor (65mbar / 1 PSI) Serial Number : 1345





Thursday 28 June 2018 12:25:53

Figure 5.1.4.ii: Automatic Sensor Detection

New sensors can also be manually configured by pressing on top of the next available sensor entry line to access the Pressure sensor settings screen.

### Editing Pressure Sensor Settings

Sensor 1	Sensor 2	Sensor 3	Sensor 4	Sensor 5	Sensor 6	Sensor 7	Sensor 8	Sensor 9	Sensor 10
#	Description								Value
1	Sensor Enabled								Disabled
2	Sensor Name								Sensor 1
3	Sensor Type								MM80006 Gas Sensor (65mbar / 1 PSI)
4	Sensor Serial Number								0
5	High Pressure Error Level								Disabled
6	High Pressure Warning Level								Disabled
7	Low Pressure Warning Level								Disabled
8	Low Pressure Error Level								Disabled
9	Action on Communications Failure								Generates Warning
10	Associate with Boiler								Independent
11	Unused								0
12	Unused								0
13	Unused								0
14	Unused								0
15	Unused								0
16	Unused								0
17	Unused								0
18	Unused								0
19	Unused								0
20	Unused								0

Thursday 21 June 2018 15:02:37

Figure 5.1.4.iii: Pressure Sensor Settings

The pressure sensor settings screens allows enabling and disabling sensors, configure sensor type and its serial number, set as independent or associate it with a boiler. It also allows setting High and Low pressure levels to generate fault conditions.

Use the tabs at the top of the display to change between each Sensor's settings screen. Any number of options can be changed at any time. When the changes have been made to configure the sensors, press Exit to save and go back to the Configured Sensors screen.

#	Default	Range	Description
1	0	0 1	<u>Sensor Enabled</u> Disabled Enabled
2			<u>Sensor Name</u>
3	0	0 1 2 3 4 5 6	<u>Sensor Type</u> MM80006 Gas Sensor (65mbar / 1 PSI) MM80008 Gas Sensor (137mbar / 5 PSI) MM80011 Gas Sensor (1034mbar / 15 PSI) MM80012 Gas Sensor (2068mbar / 30 PSI) MM80014 Gas Sensor (6894mbar / 100PSI) MM80005 Air Sensor (65mbar / 1 PSI) MM0013 Air Sensor (137mbar / 2 PSI)
4	0	0 – 65535	<u>Sensor Serial Number</u> Select Sensor serial number.
5	0	0 -32767 – 32768	<u>High Pressure Error Level</u> Disabled If the current measured value is above this level an Error is generated.
6	0	0 -32767 – 32768	<u>High Pressure Warning Level</u> Disabled If the current measured value is above this level a Warning is generated.
7	0	0 -32767 – 32768	<u>Low Pressure Warning Level</u> Disabled If the current measured value is below this level a Warning is generated.
8	0	0 -32767 – 32768	<u>Low Pressure Error Level</u> Disabled If the current measured value is below this level an Error is generated.
9		0 1	<u>Action on Communications Failure</u> For setting 0, a Warning is generated if communication with the sensor is lost. For setting 1, an Error is generated if communications with the sensor is lost Generates Warning Generates Error
10		0 1 – 10	<u>Associate with Boiler</u> Independent Selects ID of Boiler the sensor is associated with.

### 5.3. Pressure Sensors Data

The Mk8 DTI allows to view the current pressure readings and readings history for each pressure sensor. To access this information press on any of the pressure sensors animation displayed in the DTI's home screen.

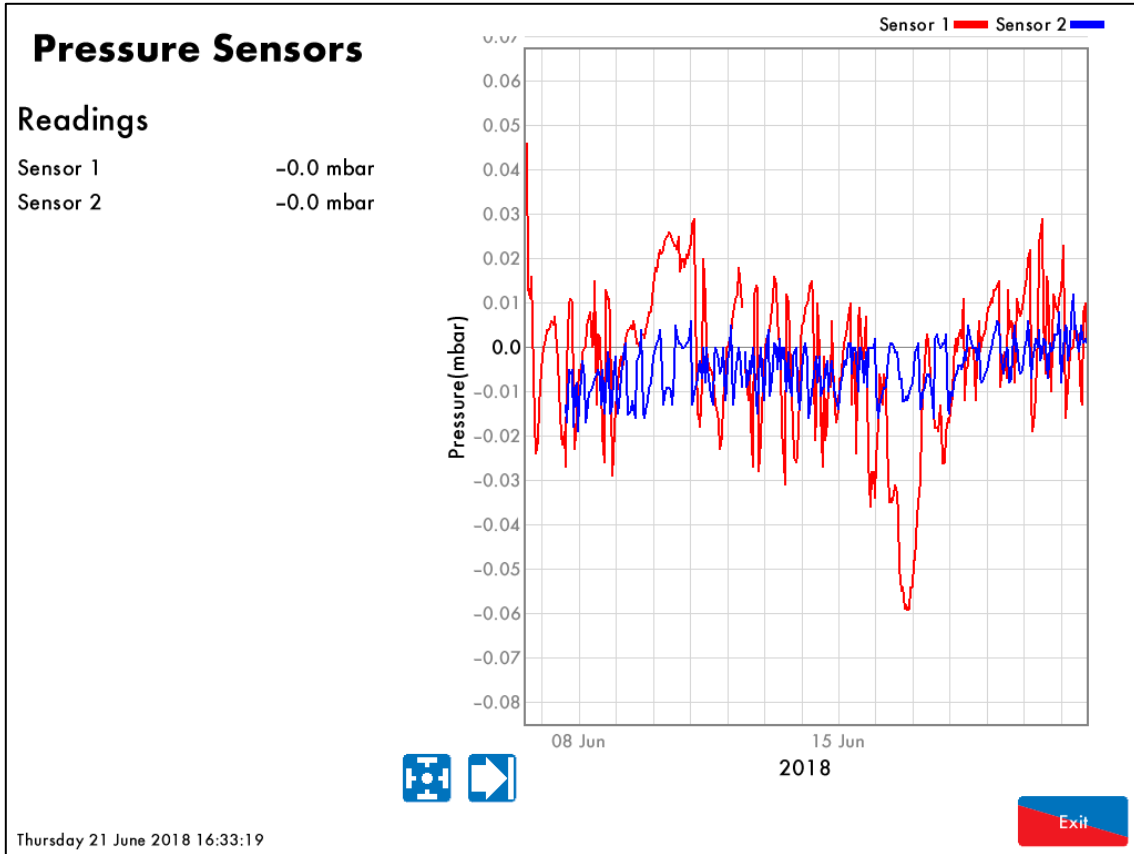

Figure 5.2.i: Pressure Sensors Screen

The Pressure Sensor screen displays the status of all the sensors connected directly to the DTI. This screen also provides history graphs for the logged data. To view or hide a sensor's history curve, press the respective sensor's line colour on top of the history graph area.



This data is logged for 2 years on the DTI. Use the   buttons to change the timescale of the data displayed, and press and drag on the axis to zoom in/out of the graph.

## 6. RULES SYSTEM

### 6.1. Introduction

The Rules System allows to set control actions on pre-set events. Rules can be set to act on events coming from any device (DTI, Pressure sensors, MMs, EGAs, I/O Modules) or at specific times of the day. According to the triggering event, a rule can be set to perform actions such as send emails, adjust individual setpoint, adjust an analogue output, trigger a digital output or even output an alarm status. Examples of rules can be seen below:

Configured Rules	
Rule	
1.	On MM Fault Occurred => Send email_address_1
2.	On EGA Fault State Changed => Send email_address_2
3.	On DTI Fault State Changed => Send 3 Recipients
4.	On DTI Fault Occurred => Send 5 Recipients
5.	Copy IO Module 1 Digital Input 1 => IO Module (IO Module 1) Digital Output 1
6.	On IO Module 1 Digital Input 1 Off => Set IO Module (IO Module 1) Analogue Output 1 to 50.0 l/s
7.	At 0:00 DTI Fault => 4 Recipients
8.	Invert IO Module 1 Digital Input 1 => IO Module (IO Module 1) Digital Output 2
9.	On IO Module 1 Digital Input 1 On => Set IO Module (IO Module 1) Analogue Output 1 to 15.0 l/s
10.	Pressure Sensor (Sensor 1) Pressure Reading Less than 2.0mbar => Set DTI Fault (Fault 1) Non-Recycling Er
11.	On IO Module 1 Digital Input 1 On => Set IO Module (IO Module 2) Analogue Output 1 to 7.0 V
12.	On DTI Fault Occurred => Set IO Module (IO Module 1) Digital Output 8 to On
13.	On DTI Fault Cleared => Set IO Module (IO Module 1) Digital Output 8 to Off
14.	Copy IO Module 1 Digital Input 1 => DTI Fault (Fault 2) Recycling Error
15.	On IO Module 1 Digital Input 1 On => Set DTI Fault (Fault 3) Non-Recycling Error
16.	On MM Fault State Changed => Send 2 Recipients
17.	At 0:00 DTI Fault => MM Id 1 Change Individual Firing Rate
18.	IO Module Analogue Input 1 More than 11.0 V => MM Id 1 Burner Disable to On
19.	Invert IO Module 1 Digital Input 11 => IO Module (IO Module 2) Digital Output 4
20.	Unused
21.	Unused
22.	Unused

Monday 23 July 2018 08:45:13



Figure 6.1.i: Configured Rules

A maximum of 100 rules can be configured allowing extensive monitoring and control of the boiler house equipment. Equipment status emails, such as fault status of an MM, can be sent to either a single email recipient or multiple, up to 10, recipients. The recipients email addresses are set in the addresses book in the DTI Settings screen.

Events can also trigger faults, for example if a pressure goes above a set threshold. The fault to be generated can be chosen to be an Error or a Warning. It can also have one the following functions.

Function	Description
Non-Recycling	Requires a manual reset of the fault to retrigger the rule.
Recycling	Resets the fault automatically when the input status changes.

## 6.2. Configuring Rules



To view the rules screen press  in the Edit Configuration screen to access the Configured Rules screen. This screen will display all the configured rules once rules have been configured.

Configured Rules	
Rule	
1. Unused	
2. Unused	
3. Unused	
4. Unused	
5. Unused	
6. Unused	
7. Unused	
8. Unused	
9. Unused	
10. Unused	
11. Unused	
12. Unused	
13. Unused	
14. Unused	
15. Unused	
16. Unused	
17. Unused	
18. Unused	
19. Unused	
20. Unused	
21. Unused	
22. Unused	

Thursday 21 June 2018 15:05:04







Figure 6.2.i: Configured Rules Screen

To set up a rule press on top of the first rule entry available. The rule settings screen will then display.

Firstly, the rule has to be enabled (Option #1). Then an input device has to be selected. This input device will provide the event to trigger the rule action. The output device and output action is then required to be chosen. The settings available for the rule operation vary depending on the settings being selected. For example, the output action that can be chosen depends on which output device has been chosen. If there is an incompatibility between the devices, trigger event and action selected the rule will be shown in red at the top the screen. When the rule set up is valid the rule will show in black at the top of the screen. The rule being shown at the top of the rule setting screen will change according to the settings being chosen.



#	Default	Range	Description
1	0		<u>Rule Enable State</u>
		0	Disabled
		1	Enabled
		2	Delete
2	0		<u>Input Type</u>
			Selects Input device to trigger the rule action.
		0	MM
		1	EGA
		2	IO Module
		3	Pressure Sensor
		4	DTI
3	0		<u>Input Device</u>
			Selects ID of input device to trigger the rule action.
		0	Any
		1 – 10	Device ID
4	0		<u>Input Selection</u>
			Available Input selection is dependent of setting in Option #2.
			For Option #2 = 0,1,4
		0	Fault
			For Option #2 = 2
		0 – 21	0 – 15 Selects from Digital Inputs 1 to 15 of the respective IO Module 16 – 21 Selects from Analogue Inputs 1 to 6 of the respective IO Module
			For Option #2 = 3
		0	Pressure Reading
5	0		<u>Output Type</u>
			Selects output type.
		0	None
		1	IO Module
		2	Email
		3	DTI Fault
		4	MM Control
6	1		<u>Output Device</u>
			Available Output devices are dependent of setting in Option #5.
			For Option #5 = 0
		1	None
			For Option #5 = 1,4
		1 – 10	Selects Device ID
			For Option #5 = 2
		1 – 10	Selects Email address from Email addresses book
			For Option #5 = 3
		1 – 16	Selects DTI Fault identification number

#	Default	Range	Description
7	0		<u>Output Selection</u> Output Selection settings available are dependent of the setting in Option #5. For Option #5 = 1 0 – 7 Selects from Digital Outputs 1 to 8 respectively 8 – 13 Selects from Analogue Outputs 1 to 6 respectively  For Option #5 = 2 0 Unused  For Option #5 = 3 0 Non-Recycling Warning 1 Non-Recycling Error 2 Recycling Warning 3 Recycling Error  For Option #5 = 4 0 Burner Disable 1 Select Individual Firing Rate 2 Select Internal Firing Rate 3 Change Individual Firing Rate 4 Select Global Setpoint 5 Select Individual Setpoint 6 Select Internal Setpoint 7 Change Individual Setpoint
8	0		<u>Rule Function</u> Selects the event when the rule is meant to perform the selected output action 0 On – Performs an action when a digital input changes or an event occurs 1 Copy – Copy digital input or event state to a digital output. 2 Invert – Copy a digital input or event state to a digital output, inverting the output. 3 At – Performs action at a programmed time of day 4 Threshold – Performs action when an analogue input level passes a configurable threshold value
9	0		<u>Trigger Condition</u> Selects condition to be met to trigger the rule action. Trigger Conditions available depend of setting in Option #8. For Option #8 = 0 0 Off 1 On 2 State Change  For Option #8 = 1,2 0 Unused  For Option #8 = 3 00:00 – 23:59 Set at what time of the day to trigger the rule  For Option #8 = 4 0 Less Than 1 More Than

#	Default	Range	Description
10	0		<u>Output Value/Trigger Threshold</u> Selects output value to be assigned to the output action selected when the rule is triggered. If selected Output is Digital Output/ DTI Fault/ Disable Burner Off On
		0 1	
		0 – 65535	If selected output is Analogue Output Selects Analogue value to be output
		0 – 100	If selected output is Change Firing Rate Selects firing rate value to be assigned to the selected MM
		0 – 9999	If selected output is Change Individual Setpoint Selects Individual Setpoint to be assigned to the selected MM
		0 – 65535	If option #8 = 4 Trigger Threshold: Triggers rule when actual value goes above/below this threshold. Whether it is above or below depends on the Trigger Condition (option #9) setting
11	0		<u>Retrigger Threshold</u> Selects the threshold value that resets the rule back to its normal state. For Option #8 = 1 – 3 Unused
		0	
		0 – 65535	For Option #8 = 4 Selects retrigger threshold
12	0		<u>Output Value</u> Selects output value to be assigned to the output action selected when the rule is triggered. For Option #8 = 1 – 3 Unused
		0	
		0 1	For Option #8 = 4 If selected Output is Digital Output/ DTI Fault/ Disable Burner Off On
		0 – 65535	If selected output is Analogue Output Selects Analogue value to be output
		0 – 100	If selected output is Change Firing Rate Selects firing rate value to be assigned to the selected MM
		0 – 9999	If selected output is Change Individual Setpoint Selects Individual Setpoint to be assigned to the selected MM

## 7. MK8 DTI OPERATION

### 7.1. Home Screen

Once the DTI has been successfully configured, it is possible to view the information on each of the MMs, EGAs, Universal I/O Modules and Pressure sensors connected in the Autoflame system. By pressing on the boiler or EGA image, it is possible to view the information available from the unit as on the device's screen itself. Pressing on any pressure sensor, the screen showing all the active configured sensors will open and show the current readings as well as the logged data. Pressing on the I/O Module image will open the respective I/O module screen. This screen provides the current state of all the analogue and digital inputs and outputs being used as well as the respective logged data.

The home screen also provides access to the System Configuration, DTI Faults, Setpoints and Sequencing screens by pressing on the respective button.

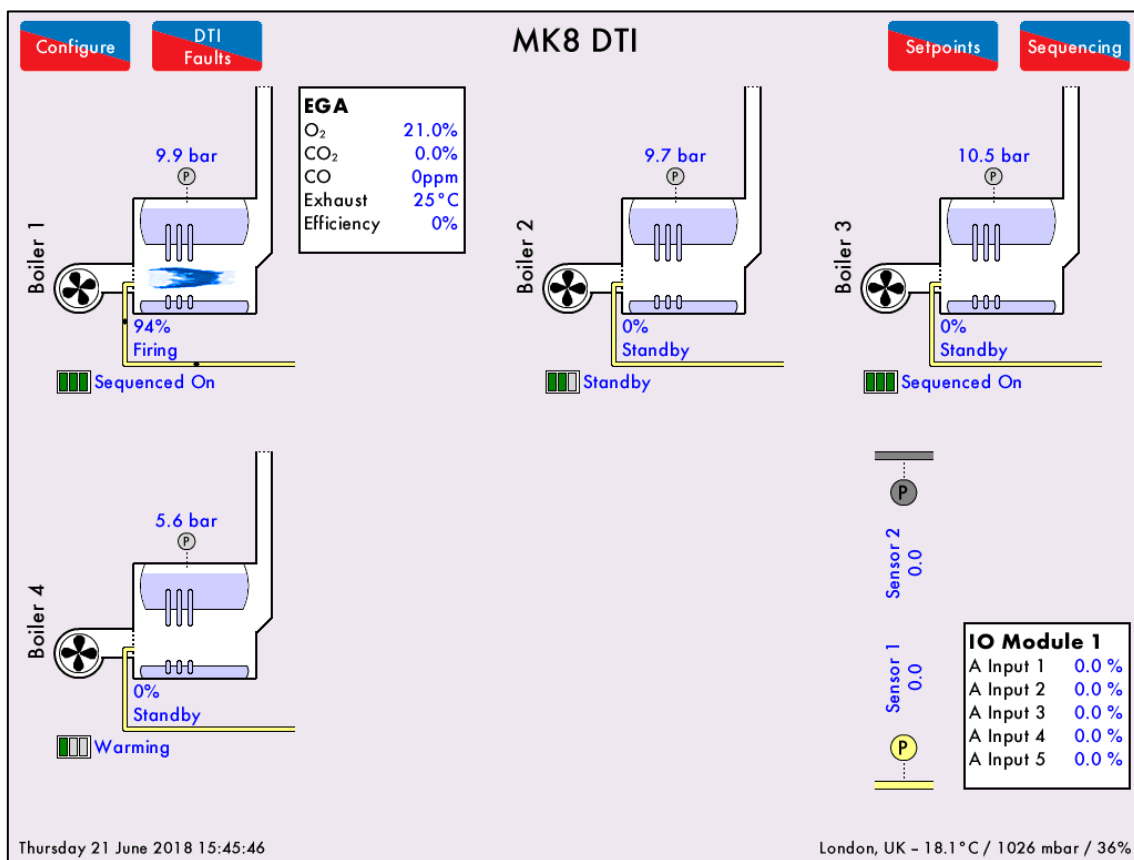



Figure 7.1.i: Boiler Room

The DTI Home screen provides the following information:

- Number of MMs/EGAs/IO Modules/Pressure Sensors
- Status of each device (device greyed out if offline)
- Firing Status of each boiler
- Sequence status of each boiler
- Actual setpoint of each boiler
- Current pressure reading of each pressure sensor
- EGA readings
- IO Module inputs and outputs status
- Location and weather (only if DTI is connected to the Ethernet)
- Date and Time
- Devices associated to each boiler (associated devices will show next to respective boiler)



## 7.2. DTI Faults Log



Press the  button in the home screen to access the faults log screen. The faults are categorised into Errors and Warning. Use the tabs at the bottom of the screen to change between the two logs. A full list of faults is available in section 10.1 of this manual.

Errors	Can Reset	Occurred	Reset
1. (10.3) Rule Fault 3		5 Jul 2018 09:42	5 Jul 2018 09:42
2. (10.2) Rule Fault 2		5 Jul 2018 09:42	5 Jul 2018 09:42
3. (10.3) Rule Fault 3		5 Jul 2018 09:41	5 Jul 2018 09:41
4. (10.2) Rule Fault 2		5 Jul 2018 09:41	5 Jul 2018 09:41
5. (10.2) Rule Fault 2		5 Jul 2018 09:40	5 Jul 2018 09:40
6. (10.3) Rule Fault 3		5 Jul 2018 09:40	5 Jul 2018 09:40
7. (10.2) Rule Fault 2		5 Jul 2018 09:40	5 Jul 2018 09:40
8. (10.3) Rule Fault 3		5 Jul 2018 09:38	5 Jul 2018 09:38
9. (10.2) Rule Fault 2		5 Jul 2018 09:38	5 Jul 2018 09:38
10. (10.2) Rule Fault 2		5 Jul 2018 09:37	5 Jul 2018 09:37
11. (10.3) Rule Fault 3		5 Jul 2018 09:37	5 Jul 2018 09:37
12. (10.2) Rule Fault 2		5 Jul 2018 09:37	5 Jul 2018 09:37
13. (10.2) Rule Fault 2		5 Jul 2018 09:37	5 Jul 2018 09:37
14. (10.3) Rule Fault 3		5 Jul 2018 09:37	5 Jul 2018 09:37
15. (10.2) Rule Fault 2		5 Jul 2018 09:37	5 Jul 2018 09:37
16. (10.3) Rule Fault 3		5 Jul 2018 09:35	5 Jul 2018 09:35
17. (10.2) Rule Fault 2		5 Jul 2018 09:35	5 Jul 2018 09:35
18. (10.2) Rule Fault 2		5 Jul 2018 09:34	5 Jul 2018 09:35
19. (10.3) Rule Fault 3		5 Jul 2018 09:34	5 Jul 2018 09:34
20. (10.2) Rule Fault 2		5 Jul 2018 09:34	5 Jul 2018 09:34
21. (10.2) Rule Fault 2		5 Jul 2018 09:33	5 Jul 2018 09:33
22. (10.2) Rule Fault 2		5 Jul 2018 09:33	5 Jul 2018 09:33
23. (10.1) Rule Fault 1		5 Jul 2018 09:32	5 Jul 2018 09:41

Errors
Warnings

Reset

Exit

Thursday 5 July 2018 12:23:15

Figure 7.2.i: Faults screen

### 7.3. Setpoints



To view the current setpoint of each boiler, press **Setpoints** in the home screen. The setpoints screen shows the set point of each boiler as well as which type of setpoint is being used. Offline boilers will be greyed out.

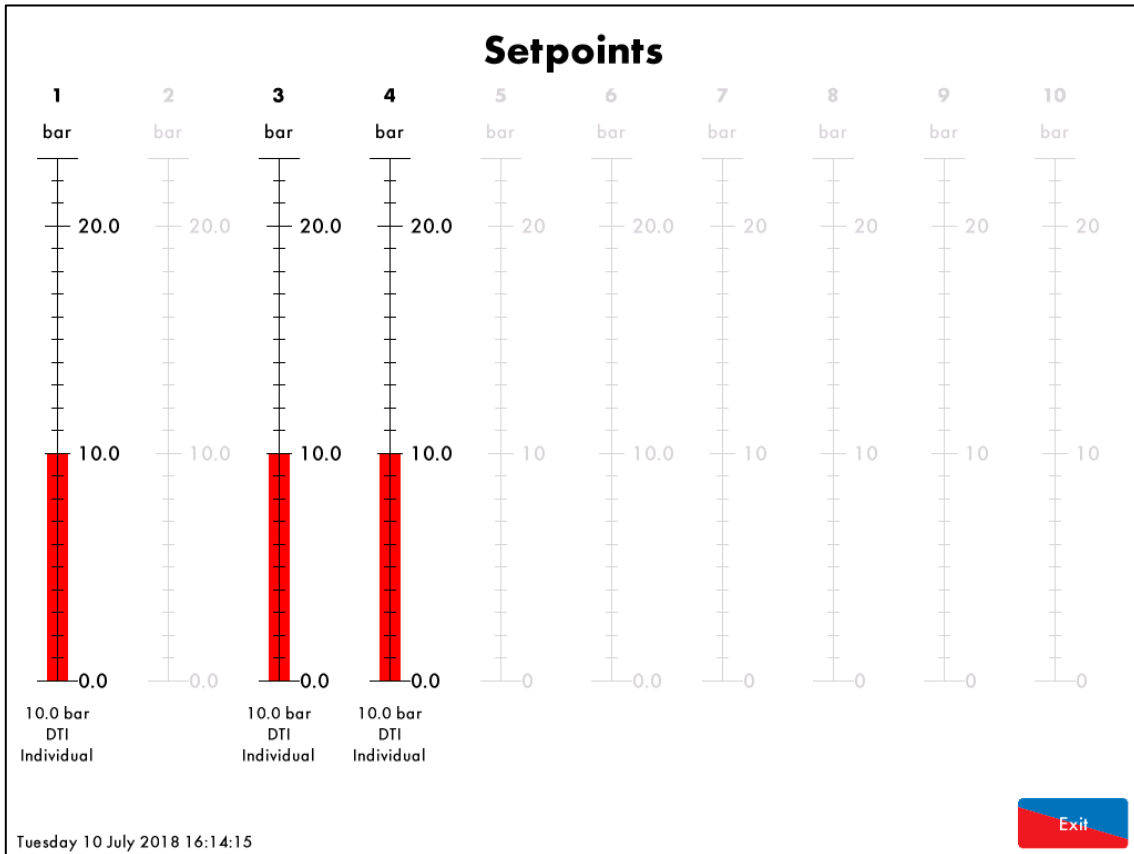

Figure 7.3.i: Setpoints screen

### 7.4. Sequencing



Press **Sequencing** in the home screen to access the sequencing screen. This screen shows the sequencing state of each boiler (On, Standby, Warming, Off) as well as the firing rate. It also indicates the lead boiler and how the lead boiler selection is being done. If auto Lead Boiler Rotation is enabled, this screen also indicates when the next rotation will occur.

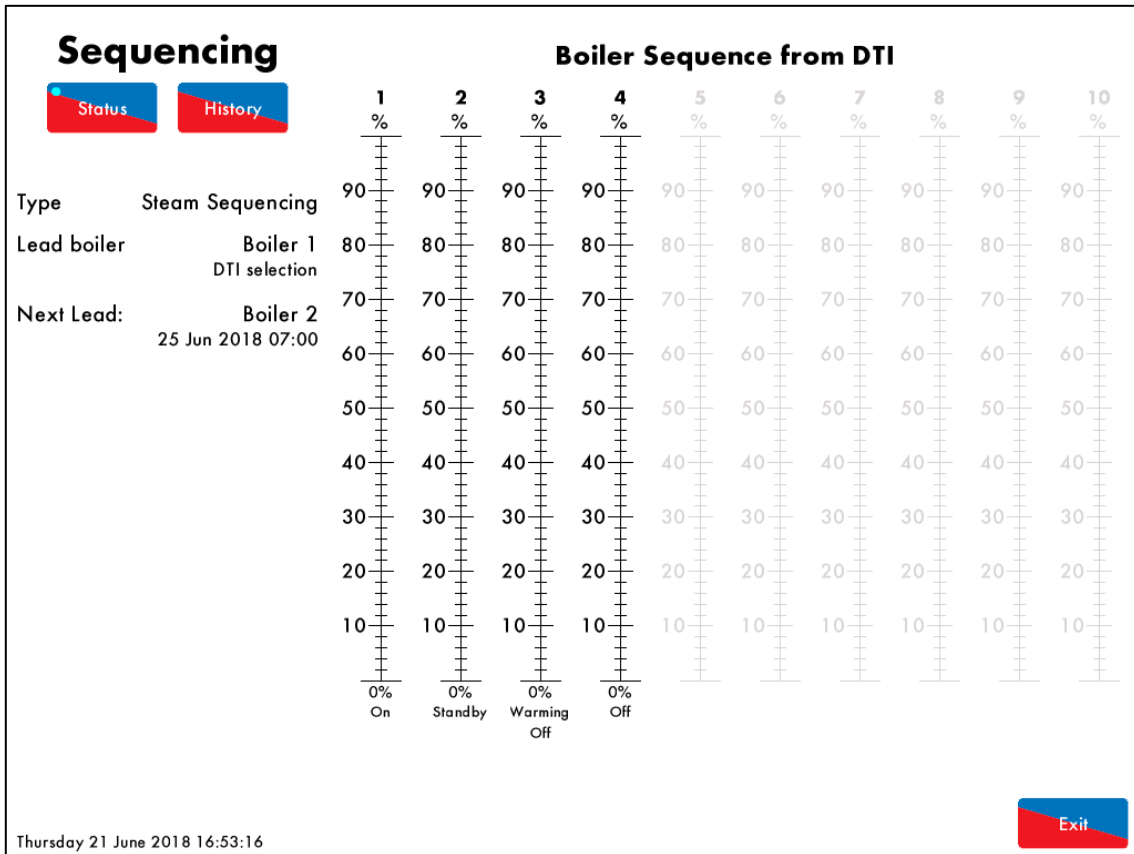

Figure 7.4.i: Sequencing Screen



To view the logged firing rates for each boiler, press the **History** button to display the history graph.

### 7.5. Setpoint Control



To access the Setpoint Control screen press **Setpoint Control** in the System Configurations screen. The user will be requested to enter the Control Password to access this control functionality.

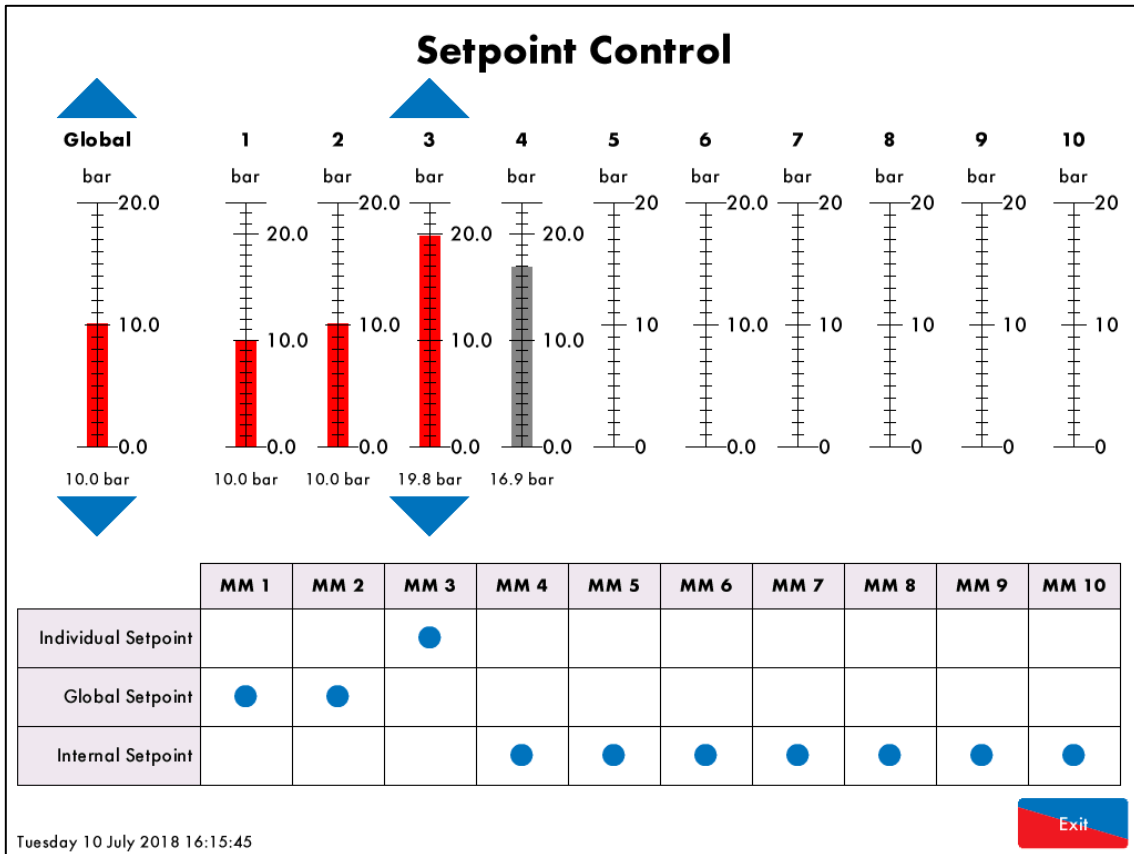

Figure 7.5.i: Setpoint Control Screen

From the Setpoint Control screen the user can choose and adjust which kind of setpoint applies to each MM. There are three options to choose from:

- Individual Setpoint – individual MM setpoint, set individually on the DTI, use respective Up/Down arrows to adjust an individual value
- Global Setpoint – common setpoint to all MMs that have this option selected, use respective Up/Down arrows to adjust value
- Internal Setpoint – MM setpoint as set on the MM itself

### 7.6. Firing Rate Control



To access the Firing Rate Control screen press **Firing Rate Control** in the Sytem Configurations screen. The user will be requested to enter the Control Password to access this control functionality.

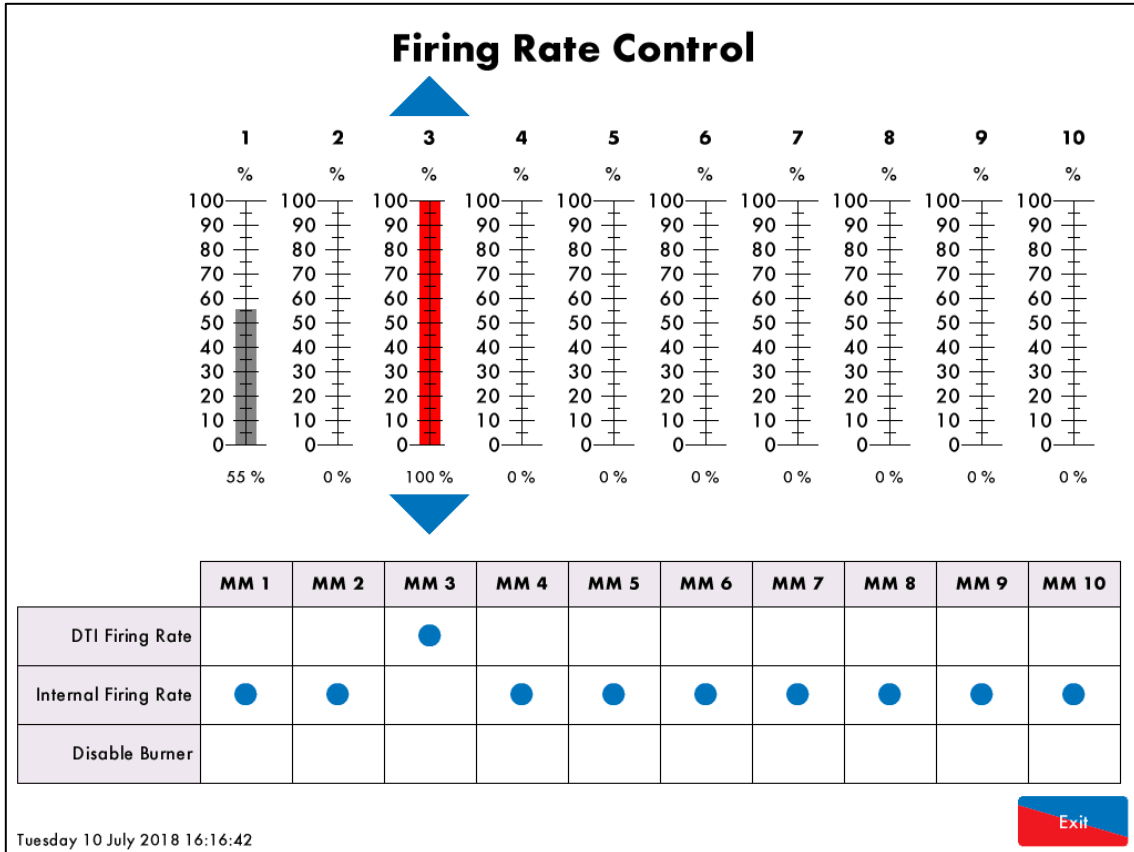

Figure 7.6.i: Firing Rate Control Screen

From the Firing Rate Control screen the user can disable and enable individual burners and choose which kind of firing rate control applies to each MM. There are two options to choose from:

- DTI Firing Rate – manual firing rate control from the DTI screen via the UP/DOWN arrows
- Internal Firing Rate – normal firing rate control by the MM’s PID controller

### 7.7. Sequence Control



To access the Sequence Control screen press  in the Sytem Configurations screen. The user will be requested to enter the Control Password to access this control functionality.

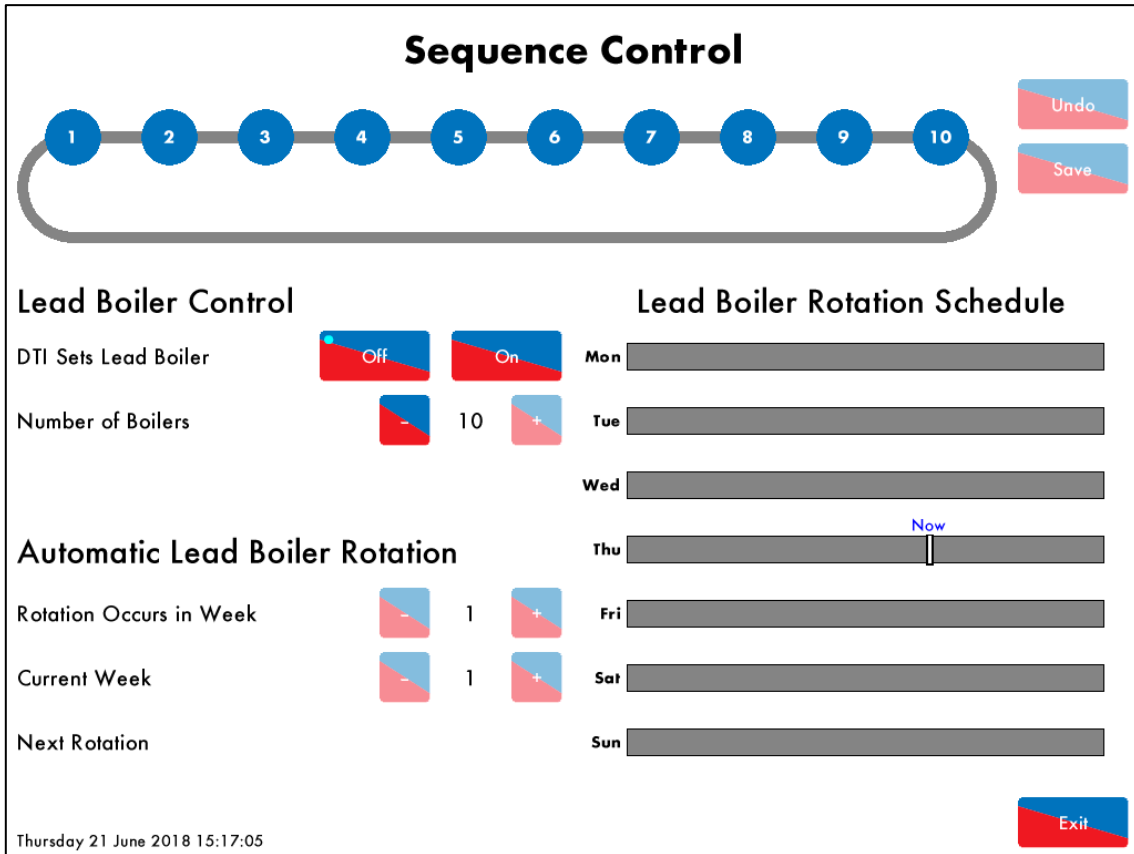



Figure 7.7.i: Sequence Control Screen

From the Sequence control screen the user is able to choose if the Lead Boiler is selected from the DTI or not.



If the  button is selected then following control features are available from this screen.

- Select number of boilers in the sequencing loop – use +/- buttons to select how many boilers are sequencing
- Select Sequencing Order – press on top of the desired  and shift right/left to change the order

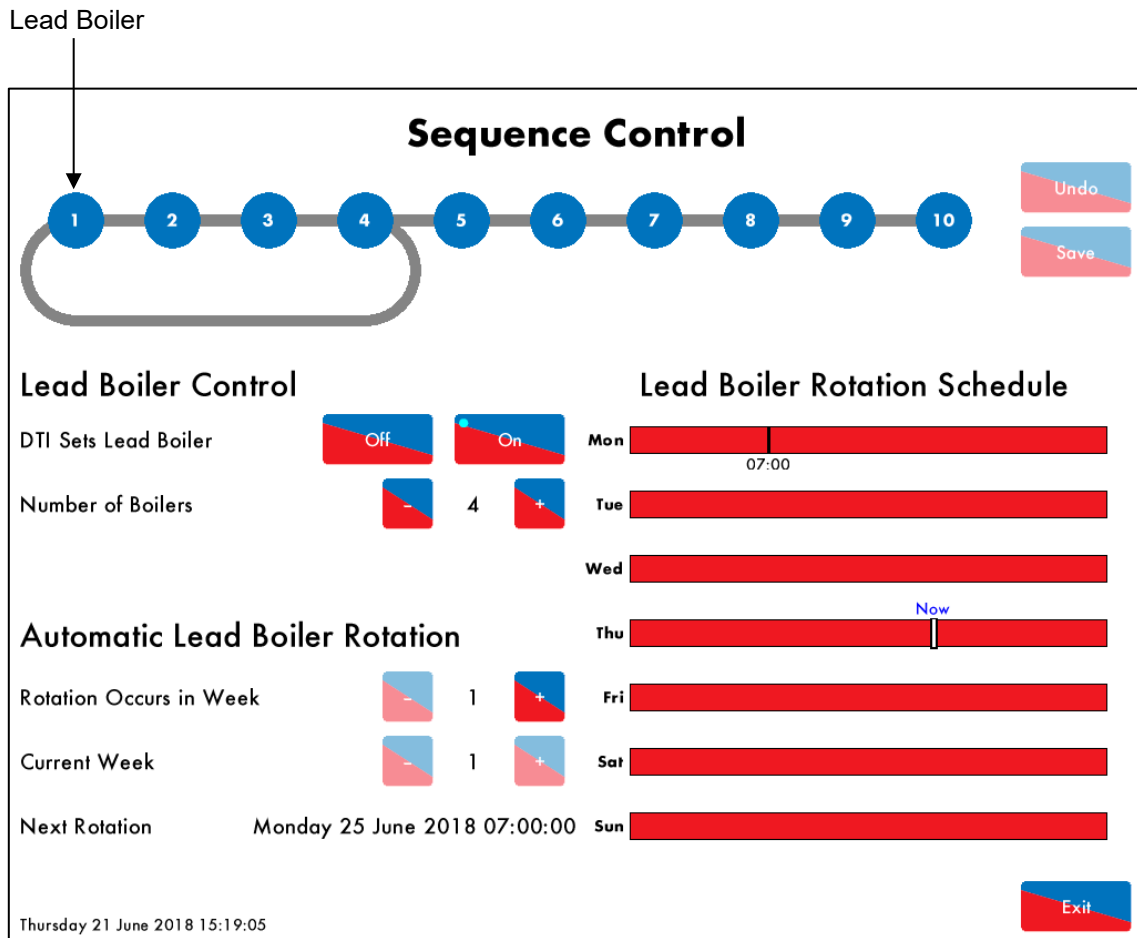

Figure 7.7.ii: DTI Controls Lead Boiler



To make the DTI to select the Lead Boiler the  button needs to be selected. Once this is selected the following sequence control features will become enabled.

- Select Lead boiler – the ID number on the very left of the sequence loop indicates the ID number of the Lead boiler
- Set automatic lead boiler rotation – set week day and time for the lead boiler change, set frequency of rotation

To set the Automatic Lead Boiler rotation, press on top of the red bar corresponding to the desired weekday for the rotation to take place.

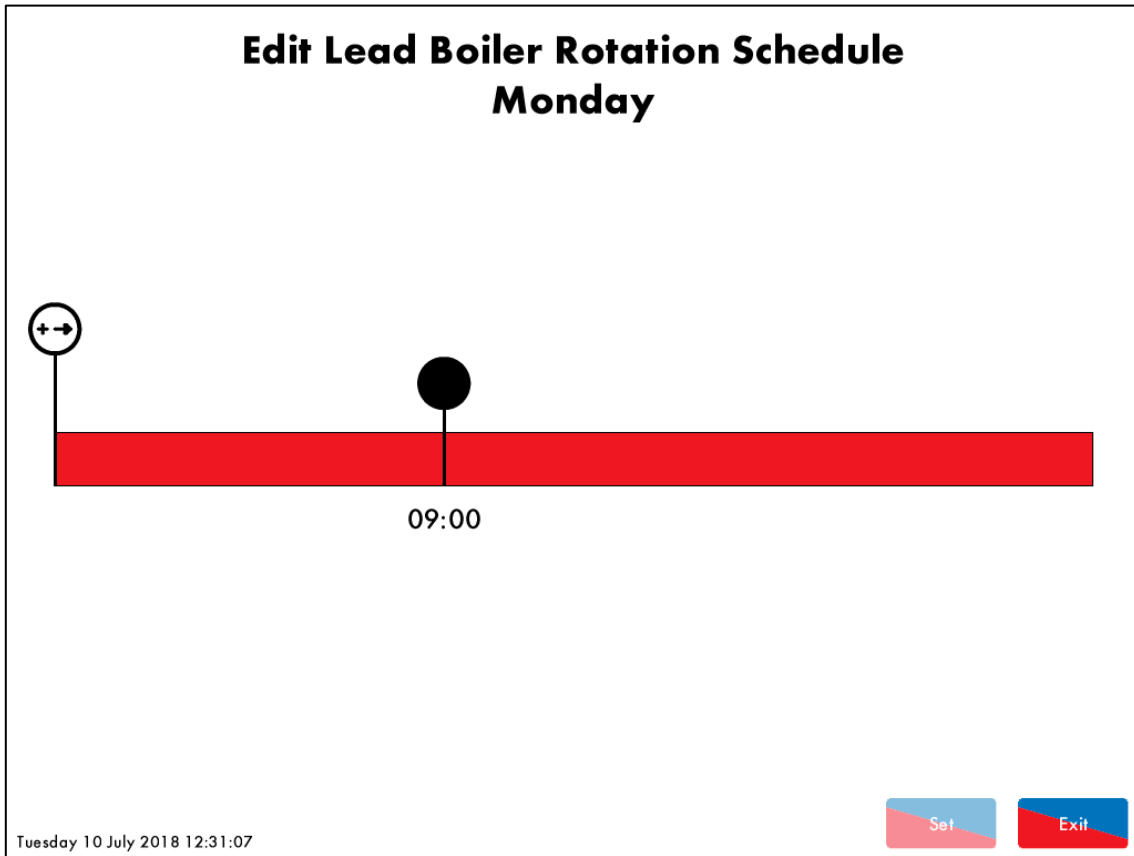









Figure 7.7.iii: Rotation Schedule

Press  and drag rightwards to add a rotation time which then shows as . To remove a time press  and drag upwards. Once the time has been added, press  and then  to return to the Sequence Control screen.

Up to 10 rotation times can be set for one week.

Use  and  in front of 'Rotation Occurs in Week' to select the frequency of rotation. For example, set to '1' means weekly rotation and '3' means rotation takes place every 3 weeks.



## 7.8. System Log



Press  in the System Configuration screen to view the System Log screen. The logs can be navigated using the up and down arrows. The logs can also be grouped by category using the 'Faults' and 'Config' tabs at the bottom of the display.

System Log	Detail	Occurred
1. Lead boiler rotation count changed	4 Lead boilers	21 Jun 2018 15:18
2. Lead boiler rotation count changed	5 Lead boilers	21 Jun 2018 15:18
3. Lead boiler rotation count changed	6 Lead boilers	21 Jun 2018 15:18
4. Lead boiler rotation count changed	7 Lead boilers	21 Jun 2018 15:18
5. Lead boiler rotation count changed	8 Lead boilers	21 Jun 2018 15:18
6. Lead boiler rotation count changed	9 Lead boilers	21 Jun 2018 15:18
7. Lead boiler rotation config changed		21 Jun 2018 15:18
8. Lead boiler changed	MM 1	21 Jun 2018 15:17
9. DTI lead boiler control	MM 1	21 Jun 2018 15:17
10. MM sequence changed	1,2,3,4,5,6,7,8,9,10	21 Jun 2018 15:16
11. Lead boiler rotation count changed	10 Lead boilers	21 Jun 2018 15:16
12. Lead boiler rotation count changed	9 Lead boilers	21 Jun 2018 15:16
13. Lead boiler rotation count changed	8 Lead boilers	21 Jun 2018 15:16
14. Lead boiler rotation count changed	7 Lead boilers	21 Jun 2018 15:16
15. Lead boiler rotation count changed	6 Lead boilers	21 Jun 2018 15:16
16. Lead boiler changed	MM 0	21 Jun 2018 15:16
17. DTI lead boiler control	No lead boiler	21 Jun 2018 15:16
18. Lead boiler rotation count changed	5 Lead boilers	21 Jun 2018 15:16
19. Lead boiler rotation count changed	4 Lead boilers	21 Jun 2018 15:16
20. Lead boiler rotation count changed	5 Lead boilers	21 Jun 2018 15:16
21. Lead boiler rotation count changed	6 Lead boilers	21 Jun 2018 15:16
22. Lead boiler rotation count changed	7 Lead boilers	21 Jun 2018 15:16

All
Faults
Config

Thursday 21 June 2018 15:23:14

Figure 7.8.i: System Log Screen

The System Log can store up to 1000 entries of the following information:

- Setting changes
- Errors/Warnings
- Remote client connection/disconnection
- DTI Restarts
- User controlled Setpoint changes
- User controlled Firing rate changes
- Sequence Rotation (manual/automatic rotation)

## 7.9. Network Diagnostics



Press **Network Diagnostics** in the System Configuration screen to access the Network Diagnostics screen. This screen allows viewing the status of the network connections. The Rx and Tx LED animations will blink if data is being received and transmitted, respectively. If DHCP is enabled, this screen allows to verify that the DTI received all the network details and is available on the network. It is also possible to detect if the email and network time services are operating properly. When remote connections are established with the DTI, this screen will show how many remote clients are connected. A maximum of three remote client connections are allowed over the Ethernet at any one time.

Network Diagnostics		Tx ●
Description		Rx ●
	Value	
Full Name	dti	
MAC Address	FC.C2.3D.01.4E.22	
IP Address	10.0.0.112	
Subnet Mask	255.255.240.0	
Default Gateway	10.0.0.254	
Primary DNS Server	10.0.16.1	
Secondary DNS Server	10.0.16.3	
Network Time Server	10.0.16.1	
Network Time Last Update	21 Jun 2018 15:50	
SMTP Mail Server	10.0.16.2	
SMTP Mail Status	2 Message(s) Sent	
Weather Service	Not Enabled	
Monitoring Service	Not Enabled	
Remote Client Count	0 / 3	
Modbus TCP Client Count	0 / 3	

Thursday 21 June 2018 15:20:20

Test Email
Refresh
Exit

Figure 7.9.i: Network Diagnostics screen

## 7.10. Modbus Diagnostics

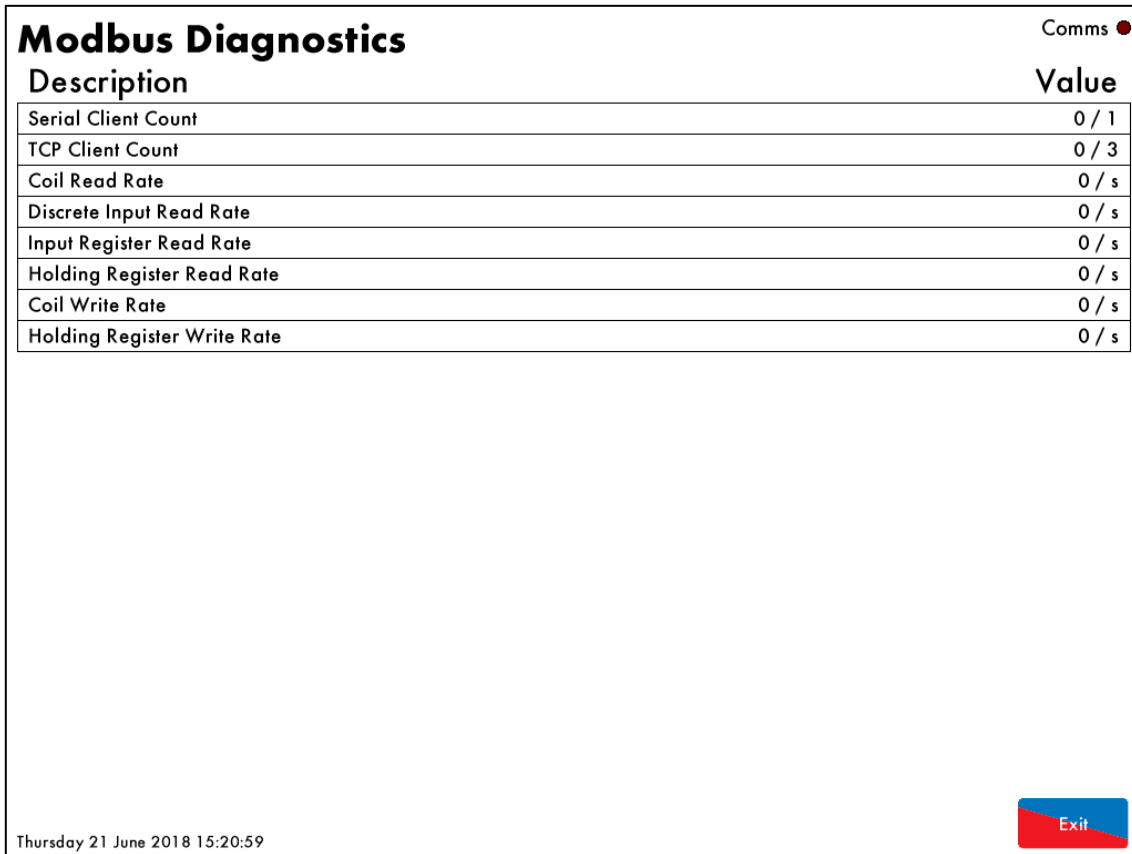

Press  in the System Configuration screen to access the Modbus Diagnostics screen. This screen allows verifying if Modbus communications are being established. It provides information on how many clients are connected to the DTI at any one Time. The DTI allow a single Serial client connection and up to 3 TCP Client connections at any one time. It also provides information on how many addresses are being written to or read from per second.

The screenshot shows the 'Modbus Diagnostics' screen. At the top left is the title 'Modbus Diagnostics' and at the top right is 'Comms' with a red dot. Below the title is a table with two columns: 'Description' and 'Value'. The table lists eight metrics, all with a value of 0. At the bottom left is the timestamp 'Thursday 21 June 2018 15:20:59' and at the bottom right is a red 'Exit' button.

Description	Value
Serial Client Count	0 / 1
TCP Client Count	0 / 3
Coil Read Rate	0 / s
Discrete Input Read Rate	0 / s
Input Register Read Rate	0 / s
Holding Register Read Rate	0 / s
Coil Write Rate	0 / s
Holding Register Write Rate	0 / s

Figure 7.10.i: Modbus Diagnostics screen





## **8. REMOTE ACCESS**

The MK8 DTI can be accessed remotely using the DTI Manager software or a Modbus system via Ethernet or RS422;

### Ethernet

- Direct Ethernet connection from the DTI to the PC.
- LAN (Local Area Network) connection.
- Internet connection using routing.

### RS422

- For Modbus. The DTI can communicate with external systems through the Modbus protocol and it accepts read and read/write commands.

### **8.1. PC Connection**

The DTI can be connected directly to a PC through the Ethernet. The Autoflame DTI Manager Software displays information on all the boilers in the boiler room, just as on the Mk8 DTI itself. Please see section 8.4 for more information on the DTI Manager Software and its capabilities.

As well communicating with the DTI Manager Software, the Mk8 DTI can communicate under the Modbus protocol with external communication systems. This allows remote control, and existing building controls to control aspects of the boiler operation. Through Modbus, information can be transferred and the data can be logged.



To set up the IP configuration on the PC:

1. Go to the Ethernet Settings on the PC by going to:  
Control Panel > Network and Sharing Centre > Change Adapter Settings

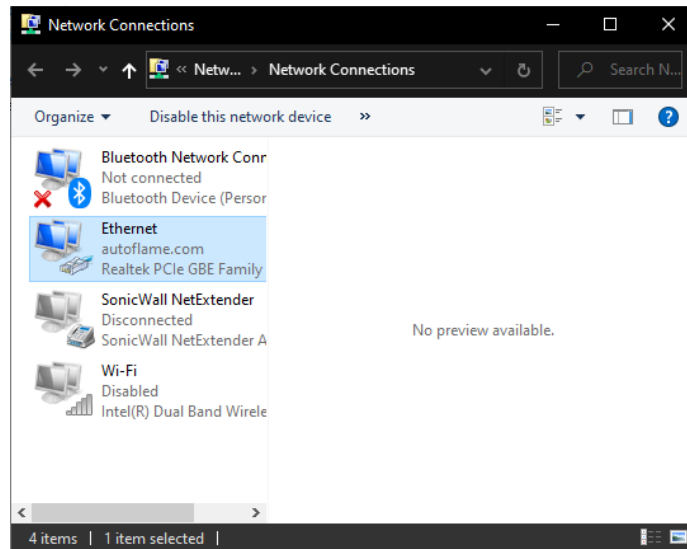

2. Right click on the Ethernet connection and go to Properties
3. Open Internet Protocol Version 4 (TCP/IPv4)

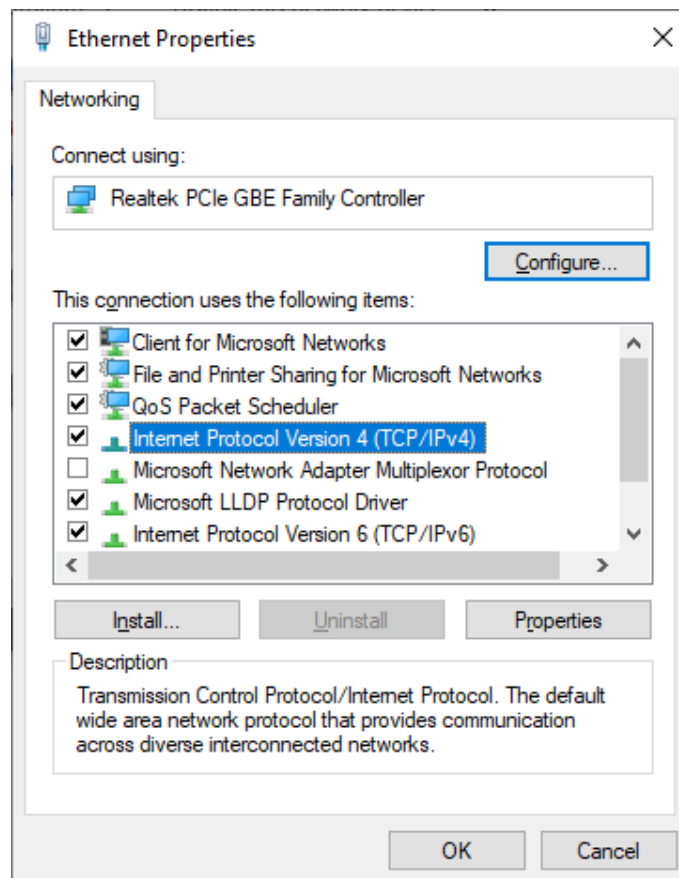

4. Select 'Use the following IP Address' – this is a way of setting the IP address manually.

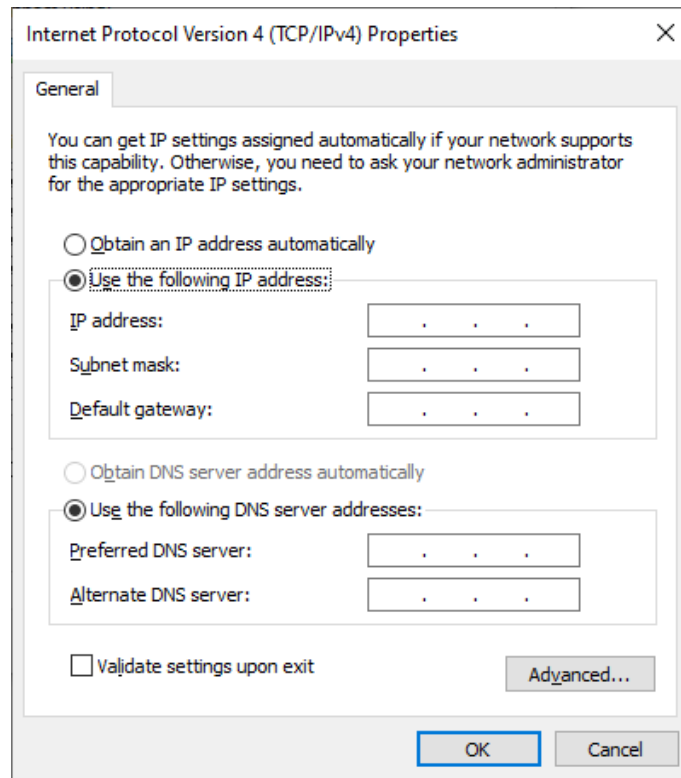

5. In the IP address box, type in an address in the same range as the DTI. i.e. if the DTI's IP address has been set to 10.0.1.80, type in 10.0.1.81.
6. In the Subnet Mask box, type the same Subnet Mask that was set on the DTI.
7. Save these settings and close the dialogue box.

Now the connection has been established between the PC and the DTI, go to the Network Diagnostics screen on the DTI to check the settings.

<b>Network Diagnostics</b>	
Description	Value
Full Name	Test.DTI
MAC Address	AB.C1.C2.01.02.3Z
IP Address	00.0.0.000
Subnet Mask	255.255.255.0
Default Gateway	00.0.0.000
Primary DNS Server	00.0.00.0
Secondary DNS Server	00.0.00.0
Network Time Server	00.0.00.0
Network Time Last Update	20 Dec 2019 14:42
SMTP Mail Server	Unresolved
SMTP Mail Status	No Messages Sent
Weather Service	8.2°C / 979 mbar / 81%
Monitoring Service	Not Enabled
Remote Client Count	3 / 3
Modbus TCP Client Count	0 / 3





6. Set the following:

#	Network Setting	Setup
40	IPV4 Address	Enter an IP Address for the Mk8 DTI
41	IPV4 Subnet Mask	Enter a useable range for IP Addresses
42	IPV4 Default Gateway	Enter address of router in range of subnet mask
45	IPV4 Primary DNS Server	Enter server address on the network that deals with device in range of subnet mask

7. Press exit to save the changes and return to the main screen.

You could check the settings by going to the Network Diagnostics screen.

Network Diagnostics	
Description	Value
Full Name	Test.DTI
MAC Address	AB.C1.C2.01.02.3Z
IP Address	00.0.0.000
Subnet Mask	255.255.255.0
Default Gateway	00.0.0.000
Primary DNS Server	00.0.00.0
Secondary DNS Server	00.0.00.0
Network Time Server	00.0.00.0
Network Time Last Update	20 Dec 2019 14:42
SMTP Mail Server	Unresolved
SMTP Mail Status	No Messages Sent
Weather Service	8.2°C / 979 mbar / 81%
Monitoring Service	Not Enabled
Remote Client Count	3 / 3
Modbus TCP Client Count	0 / 3



### 8.1.3. Connecting the DTI to the Internet

The DTI can be accessed remotely over the Internet. For that, routing needs to be configured from an external IP address to a static IP address within the LAN. A port number can be allocated/forwarded to the DTI. The MK8 DTI's port number can be changed for custom routing.

The settings for this will depend on the type of router used, please refer to the manufacturers instructions.

## 8.2. RS422 Connection

The Mk8 DTI supports Modbus protocol via RS422 connection. The DTI can be connected to a PC or a Building Management System.

Prior to establish communications between the DTI and a PC, the following settings can be adjusted on the DTI to match the communication requirements of the application. The PC/BMS also needs to be set with matching settings in order to successfully communicate with the DTI.

Option	Description	Setting
20	Modbus Mode	0. Read/Write Operation 1. Read-Only Operation
21	Modbus Address	1 – 254
22	Serial Format	0. Binary (RTU) Mode 1. ASCII Mode
23	Serial Baud Rate	0. 9600 1. 19200
24	Serial Parity	0. Even Parity (1 Stop Bit) 1. No Parity (2 Stop Bits)

The settings below are default communication settings to the DTI and cannot be changed. These will also need to be set accordingly in the PC to establish communications.

Data Bits	8	
Slave Response Timeout	2000 msecs	Time allowed for response before there is an error
Scan Rate	500 msecs	The rate the system pulls data from the DTI

Once this has been set on both the DTI and the PC/BMS, communications will be established with the DTI. If this does not connect, please request Modscan32 software from Autoflame Technical Support to check the communications from the DTI.

For a full list of Modbus addresses, please see Section 9.

For MM read/write function, option 16 must be set to either '2' or '3' on the MM.

### 8.3. DTI Manager PC Software

Autoflame DTI Manager software allows the DTI to be accessed from the user's PC, it provides and displays the same data as on the DTI screen. It also allows to operate the same control functionalities as on the DTI itself.

The DTI Manager Software operates in exactly the same way as the Mk8 DTI touch screen. When a connection is established between a PC running the DTI manager software and a Mk8 DTI, an emulation of the DTI's screen is shown on the PC which can be controlled by using mouse control or touch control (for PCs with touchscreen function running Windows OS).

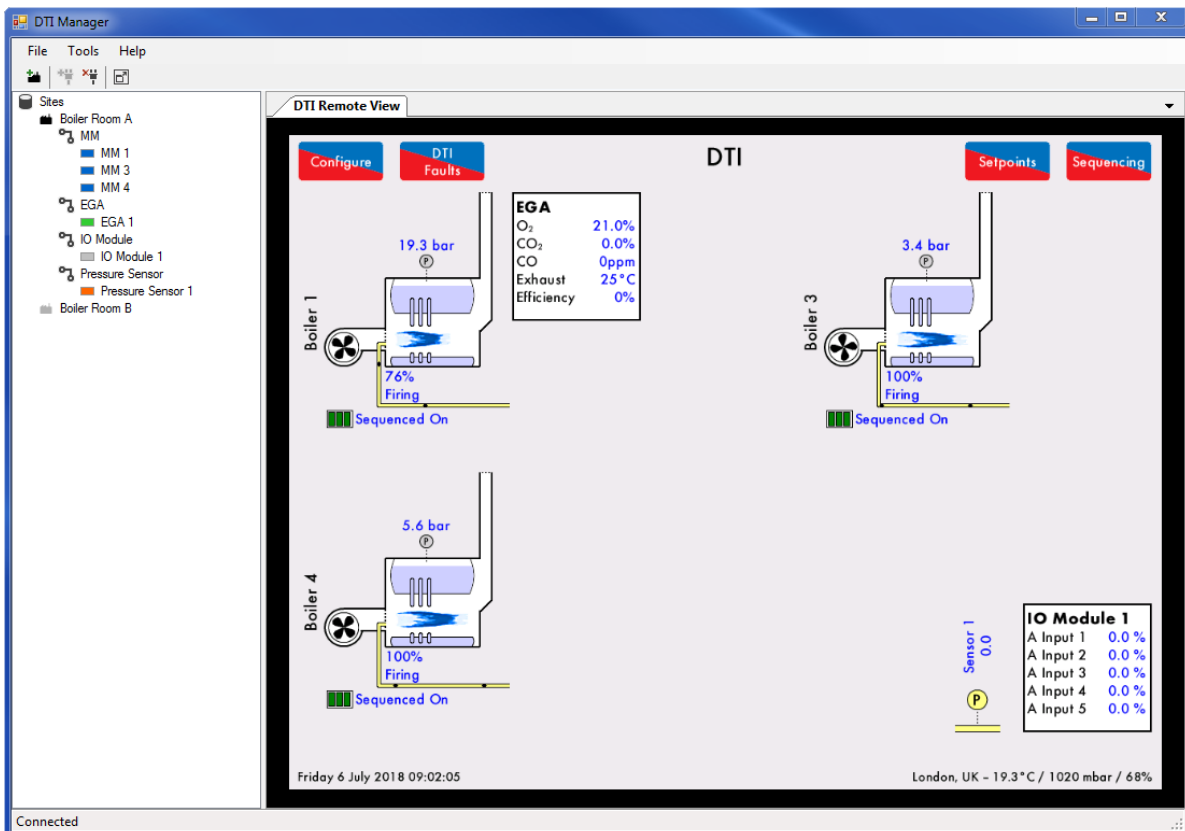

Figure 8.1.4.i: DTI Manager

#### 8.3.1. Software Requirements

The DTI Manager software must have the same version as the DTI software, for example, DTI with software version 8.04 requires DTI Manager software version 8.04.

The DTI Manager software is compatible with Windows 7, 8 and 10 in both 32 & 64bit. The software must be installed in Administrator mode.

### 8.3.2. Software license

There are two types of DTI Manager software license; Supervisor's license and Manager's license.

#### Supervisor's license

This license comes as standard with the purchase of a Mk8 DTI. The Supervisor license allows the software to be installed on multiple PCs but allows access to only one DTI (one site).

#### Manager's license

This license allows access to multiple DTIs (multiple sites) but can only be installed on a single workstation. With the DTI Manager software.

To upgrade the software from the Supervisor's license to the Manager's license, the purchase of an activation code is required, this can be ordered using part #DTI80101. Please contact Autoflame Sales or your local Autoflame Tech Centre.

To upgrade the DTI manager license, from Tools menu select License, enter the activation code and click 'Activate'

### 8.3.3. Installation

Please see Autoflame's PC software guide for the installation procedure.

### 8.3.4. Setup and Connect to a Site

Once the PC is connected to the DTI, open the DTI Manager software and click on  'Add New Site' or from File menue select 'New Site' or right click on  and select 'Add New Site'

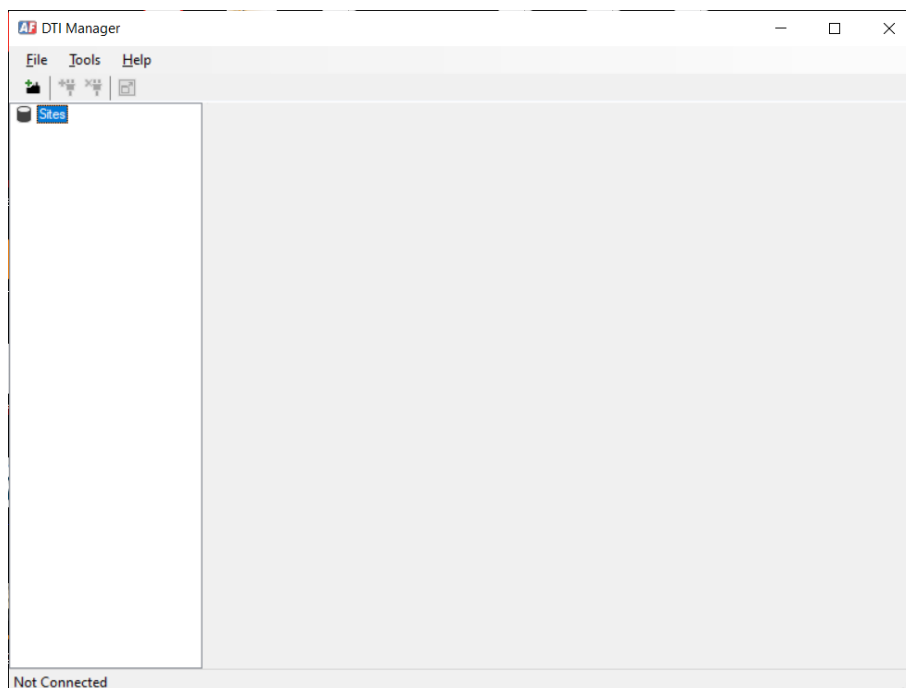

Enter the site information as below:

- Site Name: can be set as desired by the user.
- IP Address: can be found from the Network Diagnostics screen on the DTI (see section 3.4)
- Access Code: provided with the DTI, if it cannot be found please contact Autoflame.
- Password: If a password is set on the DTI, enter the same password in this field. Unless you opt to store the password, the password has to be re-entered every time you connect to this site

Once the site information has been entered, click 'OK' to close the dialogue box.

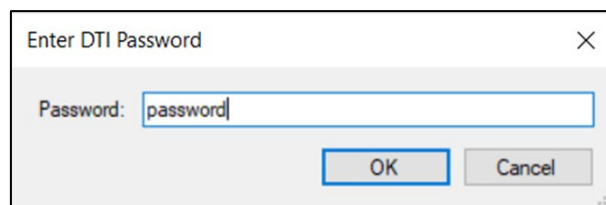
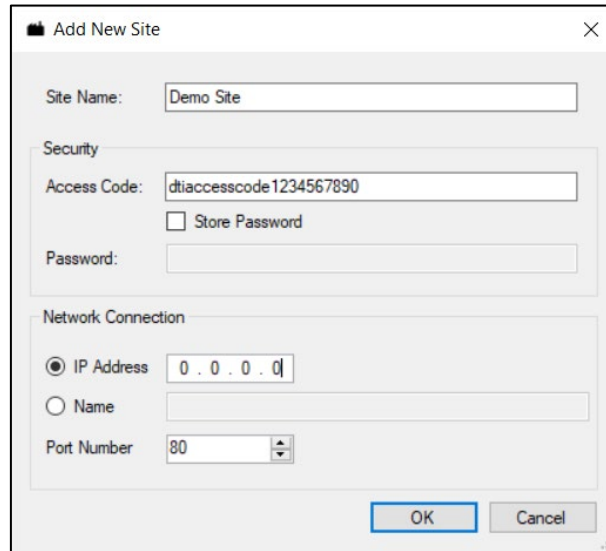

The standard Supervisor License that comes with the purchase of a Mk8 DTI allows for one site (one Mk8 DTI) to be added. The Manager's License allows for multiple sites (multiple Mk8 DTIs) to be added. Please contact Autoflame if you wish to purchase the supervisor's license.

### 8.3.5. Connect to a Site

To connect to a site, click  on the toolbar or right click on the site name on the expansion tree and select connect

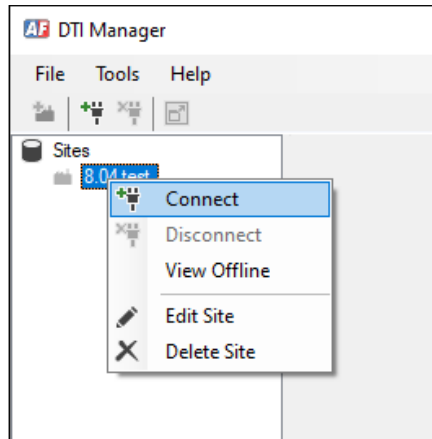

To disconnect from a site, click  or right click on the site from the expansion tree and select disconnect.

### 8.3.6. Data Accessible from the DTI Manager

The DTI Manager software displays the same information as on the Mk8 DTI screen, including the MMs EGAs, Gas pressure sensor and I/O modules linked to the DTI.

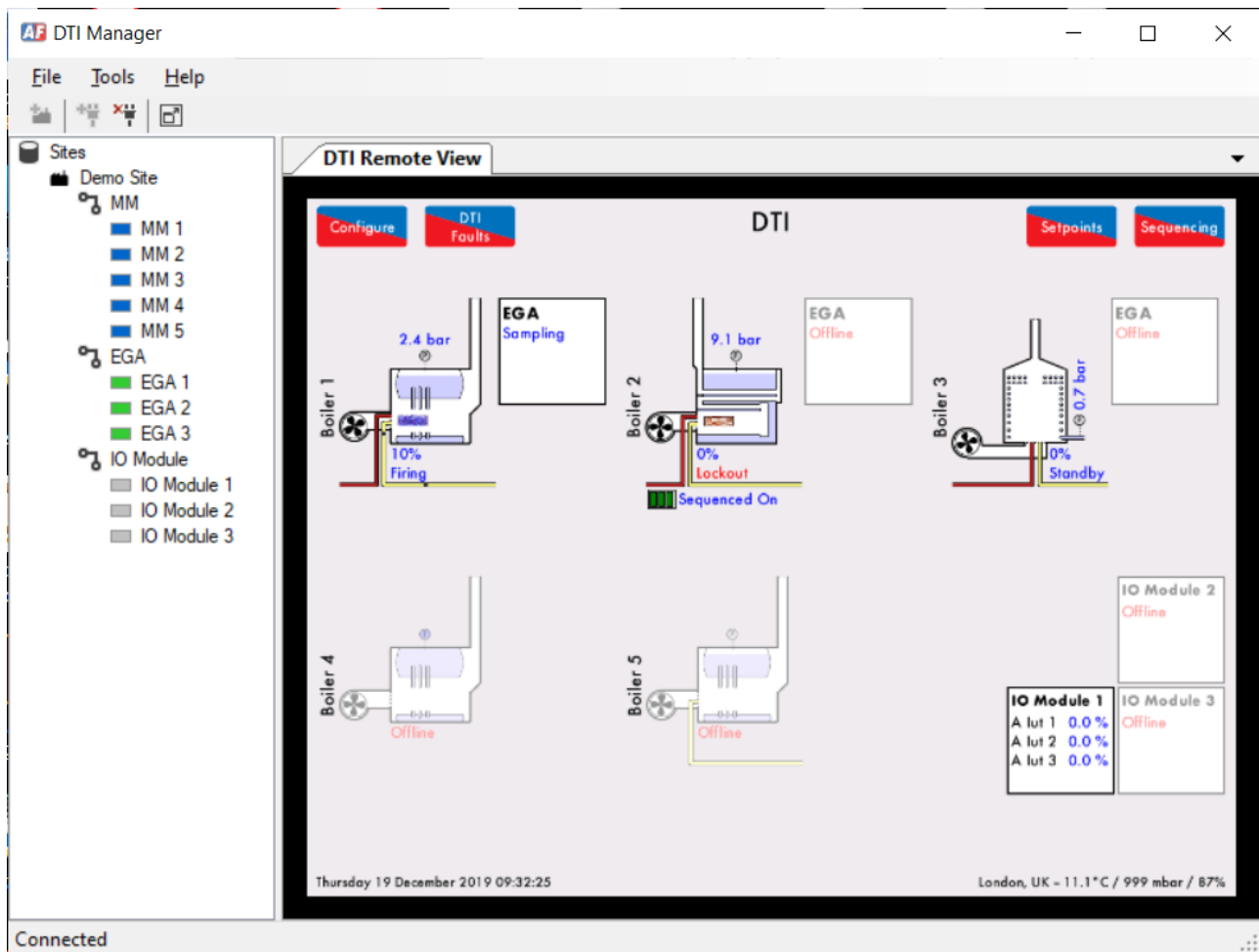

From the configure screen, the following information are available and can be configured in the same way as in the Mk8 DTI:

- Setpoint Control
- Firing Rate Control
- Sequencing Control
- The following information is available in Red Only
- Language
- Rules System
- Settings
- Boiler Settings
- IO Module Settings
- Pressure Settings
- Network Diagnostics
- Modbus Diagnostics
- Device Conflict

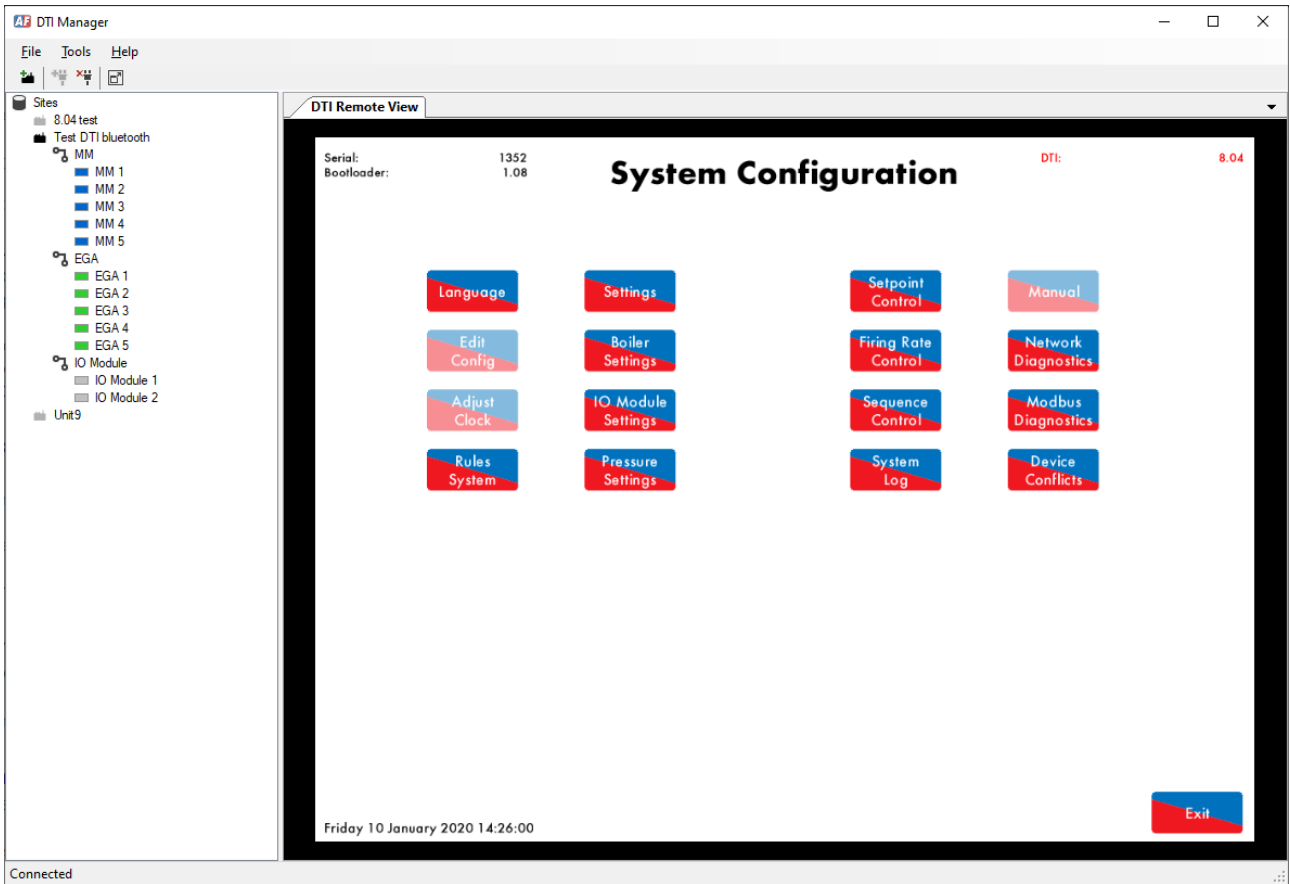

For example, the firing rate control can be adjusted from the DTI Manager.

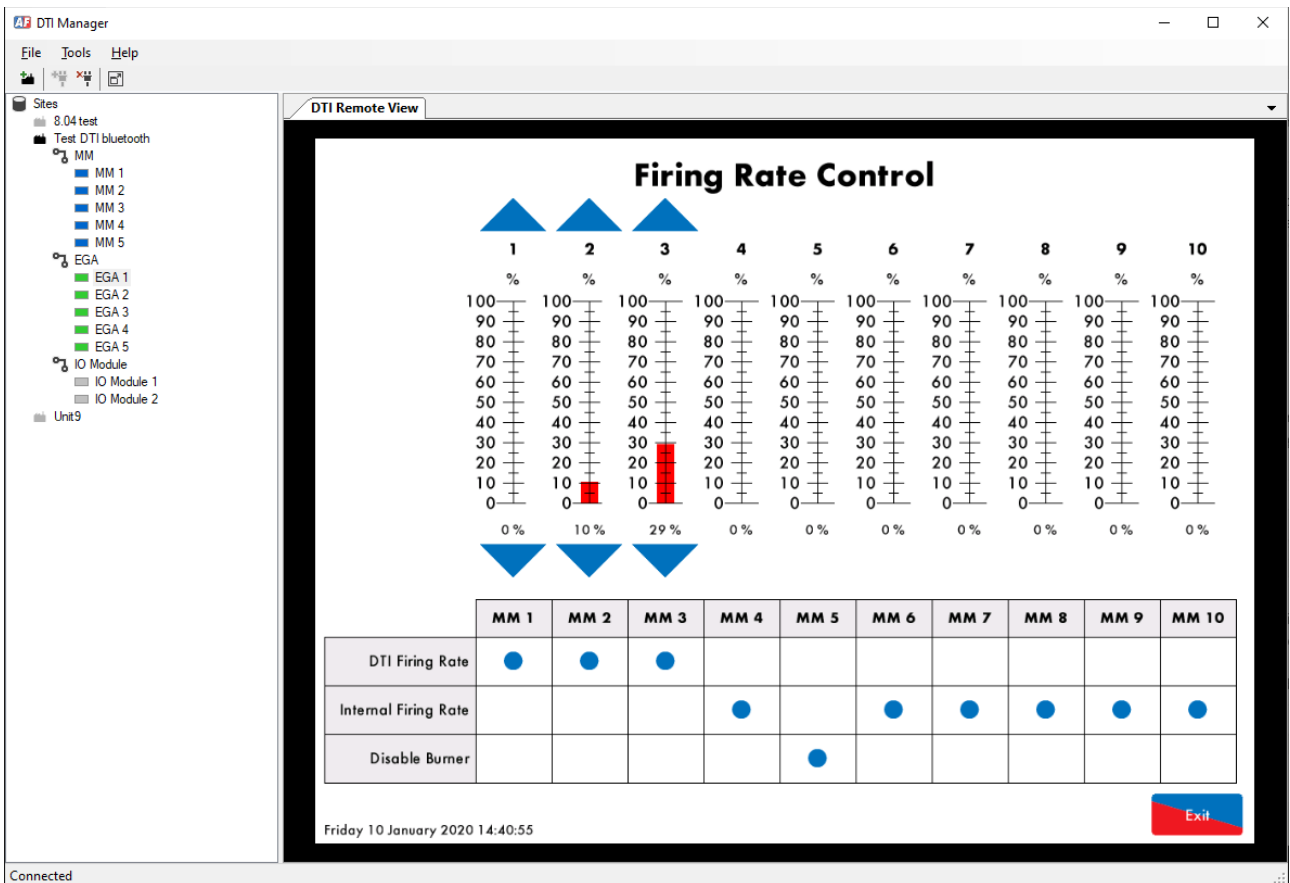

For safety and security reasons, it is not possible to change any settings under 'Edit Configuration' or 'Adjust Clock' from the DTI Manager software, these settings will appear greyed-out on the DTI Manager and can be viewed as Read-Only from the DTI Manager and can only be configured directly from the DTI. These settings include:

- Settings
- Boiler Settings
- IO Module Settings
- Pressure Settings
- Rules System
- Reset Fault Log
- Reset System Log
- Reset DTI Log
- IR Upload

### 8.3.7. View and Download Long-Term Logs

Up to 3 years' worth of boiler house data can be stored internally onboard the Mk8 DTI. The DTI Manager software allow the user to view and download the Long-Term logs from the DTI. It allows the output of up to 3 years of raw data for viewing on PC screen and downloading as an Excel spreadsheet.

### 8.3.8. Mk8 MM and Mk8 Mini MM Logs

To view these logs from the DTI Manager, right click on the MM ID and select 'View Logs'

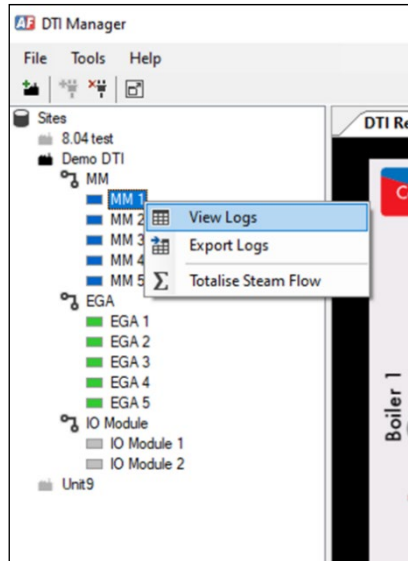

The Log Viewer will open, select which data you want to view from the menu. This viewer displays the data in a graph form, you can zoom into an area of the graph using mouse click & drag motion.

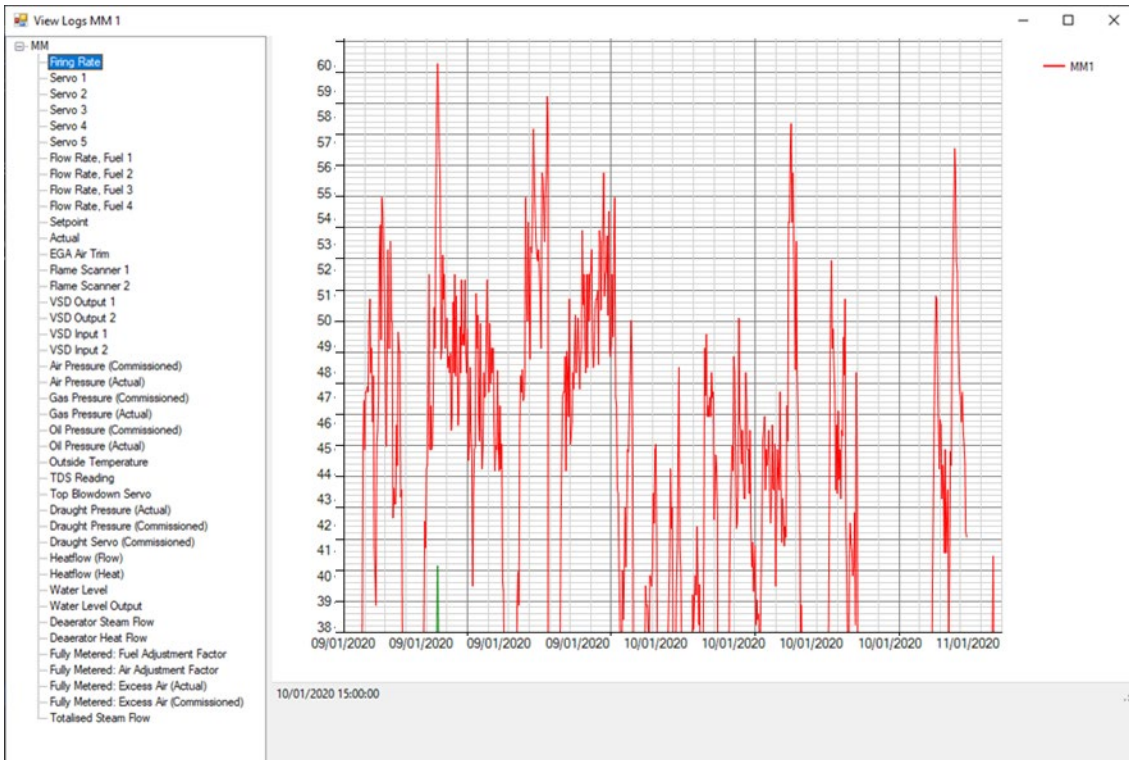

To export the logs, right click on the MM ID that you want to export the logs from, select 'Export Logs' In 'Select logs to export' dialogue box, the data available will be displayed (see below), select the data that you want to export.

The 'Select logs to export MM 3' dialog box contains the following elements:

- Resolution:** Radio buttons for Day Resolution, Hour Resolution, and Minute Resolution (selected).
- Start Time:** 13/11/2019, 00:00
- End Time:** 09/01/2020, 00:00
- Export to:** C:\Users\zaldujayli\Desktop\Demo\_DTI\_MM3\_10-01-2020\_16-02-45.xlsx
- Buttons:** Cancel, Export, and Browse.

**Selected Parameters:**

- Firing Rate
- Servo 1
- Servo 2
- Servo 3
- Servo 4
- Servo 5
- Flow Rate, Fuel 1
- Flow Rate, Fuel 2
- Flow Rate, Fuel 3
- Flow Rate, Fuel 4
- Setpoint
- Actual
- EGA Air Trim
- Flame Scanner 1
- Flame Scanner 2
- VSD Output 1
- VSD Output 2
- VSD Input 1
- VSD Input 2
- Air Pressure (Commissioned)
- Air Pressure (Actual)
- Gas Pressure (Commissioned)
- Gas Pressure (Actual)
- Oil Pressure (Commissioned)
- Oil Pressure (Actual)
- Outside Temperature
- TDS Reading
- Top Blowdown Servo
- Draught Pressure (Actual)
- Draught Pressure (Commissioned)
- Draught Servo (Commissioned)
- Heatflow (Flow)
- Heatflow (Heat)
- Water Level
- Water Level Output
- Deaerator Steam Flow
- Deaerator Heat Flow
- Fully Metered: Fuel Adjustment Factor
- Fully Metered: Air Adjustment Factor
- Fully Metered: Excess Air (Actual)
- Fully Metered: Excess Air (Commissioned)
- Totalised Steam Flow

Choose if you want to download the data in day, hour or minute Resolution. Specify the start and end time for the data to be exported. Click 'Browse' to select where you want the data to be stored on your PC.

The 'Select period to totalize' dialog box contains the following elements:

- First Day:** 08/01/2020
- Last Day:** 09/01/2020
- Export to:** (Empty text field)
- Buttons:** Cancel, Totalize, and Browse.

Click 'Export' to begin the download process. Once finalised, an Excel file will be generated with the exported data.

A totalised Steam Flow Log can also be exported from any MMs linked to the DTI.

### 8.3.9. Mk8 EGA Evo Logs

The EGA Logs can be viewed and exported via the DTI manager for any EGA linked to the DTI in the same way as in viwing or exporting logs from MMs. The DTI Manger can be used to export the following EGA logs:

Select logs to export EGA 1 ✕

Probe Temperature  
 Heated Sample Line Temperature  
 Cell Temperature  
 Pre-Heat Temperature  
 Ambient Temperature  
 Chiller Temperature  
 Inlet Pressure  
 Barometer Pressure  
 Concentration O2  
 Concentration CO2  
 Concentration CO  
 Concentration NO  
 Concentration NO2  
 Concentration SO2  
 Fuel Flow  
 Efficiency  
 Mass O2  
 Mass CO2  
 Mass CO  
 Mass NO  
 Mass NO2

Mass SO2  
 Mass H2O  
 Mass N2  
 Fuel 1 Flow Total  
 Fuel 2 Flow Total  
 Fuel 3 Flow Total  
 Fuel 4 Flow Total

Day Resolution  
  Hour Resolution  
  Minute Resolution

First Day: 
 Last Day:

Export to:  Browse

Cancel Export

Below is a sample of downloaded EGA logs

LOG DATA	Time	Exhaust Temperature (°C)	Pre-Heat Temperature (°C)	Ambient Temperature (°C)	Barometric Pressure (mbar)	O2 Concentration (%)	CO2 Concentration (%)	CO Concentration (ppm)	NO Concentration (ppm)	NO2 Concentration (ppm)	SO2 Concentration (ppm)	Efficiency (%)	O2 Mass (kg)	CO2 Mass (kg)	CO Mass (kg)	NO Mass (kg)	NO2 Mass (kg)	SO2 Mass (kg)	H2O Mass (kg)	N2 Mass (kg)	Fuel 1 Total (MWh)	Fuel 2 Total (MWh)	Fuel 3 Total (MWh)	Fuel 4 Total (MWh)	Firing (minutes)
28/06/2017 15:00	67.34	0.00	22.81	975.01	3.11	11.21	0.46	38.45	2.45	0.00	89.00	0.30	1.72	0.00	0.00	0.00	0.00	1.21	8.18	0.01	0.00	0.00	0.00	0.00	4
28/06/2017 16:00	62.45	0.00	22.75	974.99	2.80	11.45	0.13	38.67	2.47	0.00	88.85	0.34	1.58	0.00	0.00	0.00	0.00	1.11	7.77	0.01	0.00	0.00	0.00	0.00	4
28/06/2017 17:00	64.83	0.00	22.62	974.73	3.30	11.10	0.16	38.64	2.47	0.00	88.77	0.71	3.65	0.00	0.00	0.00	0.00	2.56	17.58	0.02	0.00	0.00	0.00	0.00	8
28/06/2017 18:00	67.00	0.00	22.59	974.81	3.07	11.27						0.00	0.00	0.00	0.00	0.00	0.00	0.00	0.00	0.00	0.00	0.00	0.00	0.00	0
28/06/2017 19:00			22.42	974.09								0.00	0.00	0.00	0.00	0.00	0.00	0.00	0.00	0.00	0.00	0.00	0.00	0.00	0
28/06/2017 20:00			22.18	974.03								0.00	0.00	0.00	0.00	0.00	0.00	0.00	0.00	0.00	0.00	0.00	0.00	0.00	0
28/06/2017 21:00			21.94	973.94								0.00	0.00	0.00	0.00	0.00	0.00	0.00	0.00	0.00	0.00	0.00	0.00	0.00	0
28/06/2017 22:00			21.63	973.80								0.00	0.00	0.00	0.00	0.00	0.00	0.00	0.00	0.00	0.00	0.00	0.00	0.00	0
28/06/2017 23:00			21.29	973.77								0.00	0.00	0.00	0.00	0.00	0.00	0.00	0.00	0.00	0.00	0.00	0.00	0.00	0
29/06/2017 00:00			20.94	973.75								0.00	0.00	0.00	0.00	0.00	0.00	0.00	0.00	0.00	0.00	0.00	0.00	0.00	0
29/06/2017 01:00			20.74	973.28			0.43	38.96	2.49	0.00	89.23	0.64	3.82	0.00	0.00	0.00	0.00	2.68	18.04	0.02	0.00	0.00	0.00	0.00	9
29/06/2017 02:00	54.30	0.00	20.45	973.27	2.81	11.44						0.00	0.00	0.00	0.00	0.00	0.00	0.00	0.00	0.00	0.00	0.00	0.00	0.00	0
29/06/2017 03:00			20.36	972.64								0.00	0.00	0.00	0.00	0.00	0.00	0.00	0.00	0.00	0.00	0.00	0.00	0.00	0
29/06/2017 04:00			20.24	972.04								0.00	0.00	0.00	0.00	0.00	0.00	0.00	0.00	0.00	0.00	0.00	0.00	0.00	0
29/06/2017 05:00			20.09	971.90			0.26	39.32	2.51	0.00	89.02	0.50	2.71	0.00	0.00	0.00	0.00	1.90	12.95	0.01	0.00	0.00	0.00	0.00	5
29/06/2017 06:00	58.14	0.00	19.91	972.08	3.01	11.34	0.17	39.87	2.55	0.00	88.47	2.18	10.30	0.00	0.00	0.00	0.00	7.23	50.34	0.05	0.00	0.00	0.00	0.00	18
29/06/2017 07:00	70.80	0.00	19.80	972.96	3.29	11.11	0.20	40.40	2.58	0.00	88.63	0.24	1.17	0.00	0.00	0.00	0.00	0.83	5.76	0.01	0.00	0.00	0.00	0.00	3
29/06/2017 08:00			20.20	972.44	3.24	11.05						0.00	0.00	0.00	0.00	0.00	0.00	0.00	0.00	0.00	0.00	0.00	0.00	0.00	0
29/06/2017 09:00			21.12	972.37								0.00	0.00	0.00	0.00	0.00	0.00	0.00	0.00	0.00	0.00	0.00	0.00	0.00	0
29/06/2017 10:00			21.96	972.46								0.00	0.00	0.00	0.00	0.00	0.00	0.00	0.00	0.00	0.00	0.00	0.00	0.00	0
29/06/2017 11:00			22.56	972.66			1.10	39.20	2.50	0.00	89.15	0.22	1.41	0.00	0.00	0.00	0.00	1.00	6.64	0.01	0.00	0.00	0.00	0.00	4
29/06/2017 12:00	58.50	0.00	22.77	973.38	2.64	11.47	0.54	39.56	2.53	0.00	88.54	0.55	2.76	0.00	0.00	0.00	0.00	1.95	13.42	0.01	0.00	0.00	0.00	0.00	5
29/06/2017 13:00	72.36	0.00	22.93	973.70	3.15	11.16	0.38	39.55	2.52	0.00	89.02	0.29	1.41	0.00	0.00	0.00	0.00	1.00	6.90	0.01	0.00	0.00	0.00	0.00	4
29/06/2017 14:00	61.33	0.00	23.07	974.25	3.24	11.09	0.34	39.26	2.51	0.00	89.02	0.38	1.98	0.00	0.00	0.00	0.00	1.40	9.58	0.01	0.00	0.00	0.00	0.00	5

Custom graphs for Temperature, Biometric Pressure, Gas Concentration, Efficiency, Emissions, Fuel Total, State, etc.

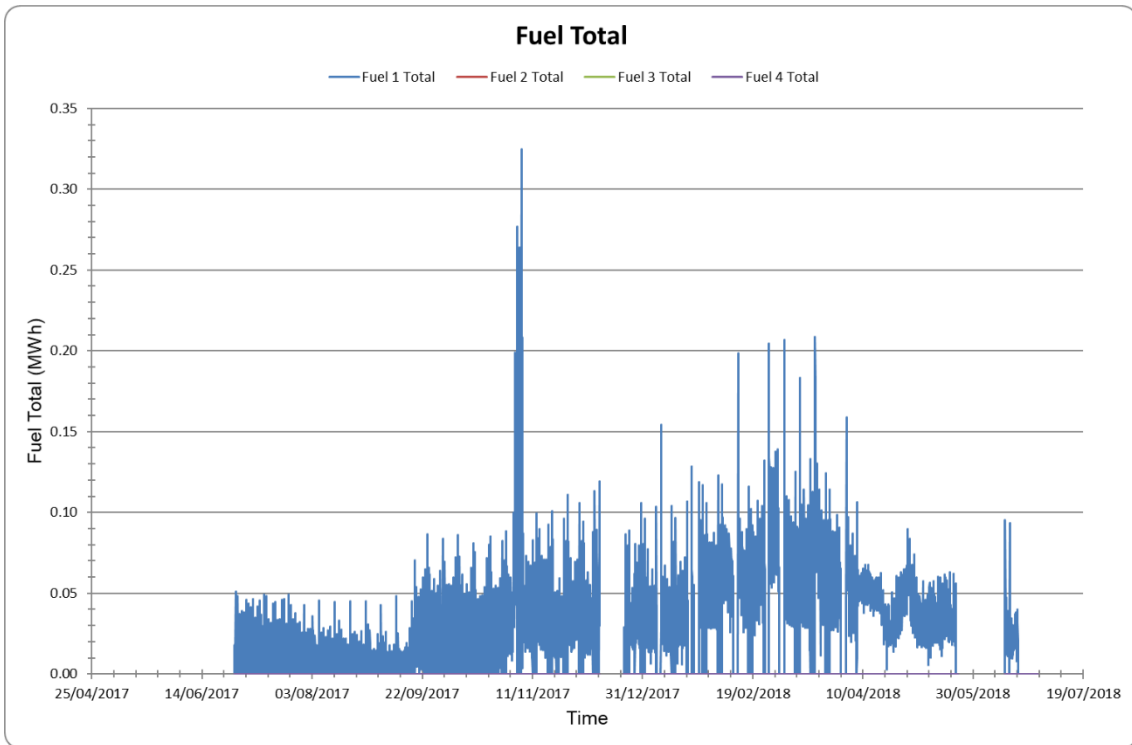

Data Overview

AUTOFLAME EGA CEMS REPORT				
Engineer Name	Lukasz			
Site Name	unit 9			
Device Id	3			
Serial Number	433			
Reporting Period	28/06/2017 15:00			
To	28/06/2018 15:00 (365 days 1 hours)			
Firing Time	2624.5 hours			
<b>System</b>	<b>Average</b>			
Inlet	15.0 °C			
Exhaust	54.1 °C			
Efficiency	88.8 %			
<b>Environment</b>	<b>Average</b>			
Pressure	984.2 mbar			
Temperature	15.0 °C			
<b>Emissions</b>	<b>Concentration</b>	<b>Mass</b>	<b>Volume</b>	
O2	2.7 %	7548 kg	5768 m <sup>3</sup>	
CO2	9.8 %	37229 kg	20687 m <sup>3</sup>	
CO	0.2 ppm	0.04 kg	0.03 m <sup>3</sup>	
NO	45.2 ppm	11.23 kg	9.15 m <sup>3</sup>	
NO2	21708.8 ppm	8144.54 kg	4329.24 m <sup>3</sup>	
SO2	0.0 ppm	0.00 kg	0.00 m <sup>3</sup>	
H2O	-	29405 kg	39916 m <sup>3</sup>	
N2	85.2 %	197786 kg	172658 m <sup>3</sup>	
<b>Fuel Setup</b>	<b>Fuel Type</b>	<b>Calorific Value</b>	<b>Specific Gravity</b>	<b>Cost Per Unit</b>
1	Natural Gas (North Sea)	50.9 MJ/kg	0.59	17.50 GBP/MWh
2	Natural Gas (North Sea)	50.9 MJ/kg	0.59	10.00 GBP/MWh
3	Natural Gas (North Sea)	50.9 MJ/kg	0.59	10.00 GBP/MWh
4	Natural Gas (North Sea)	50.9 MJ/kg	0.59	10.00 GBP/MWh
<b>Fuel Usage</b>	<b>Energy</b>	<b>Mass</b>	<b>Volume</b>	<b>Cost</b>
1	209.0 MWh	14794 kg	20469 m <sup>3</sup>	3658 GBP
2	0.0 MWh	0 kg	0 m <sup>3</sup>	0 GBP
3	0.0 MWh	0 kg	0 m <sup>3</sup>	0 GBP
4	0.0 MWh	0 kg	0 m <sup>3</sup>	0 GBP
<b>Total</b>	<b>209.0 MWh</b>	<b>14794 kg</b>	<b>20469 m<sup>3</sup></b>	<b>3658 GBP</b>

### 8.3.10. Analogue/ Digital IO Modules Logs

The Mk8 DTI stores data logs for any I/O Modules linked directly to the DTI, these logs can be viewed and exported in the same way as with exporting logs from MMs. The DTI Manger can be used to export the following I/O Modules logs:

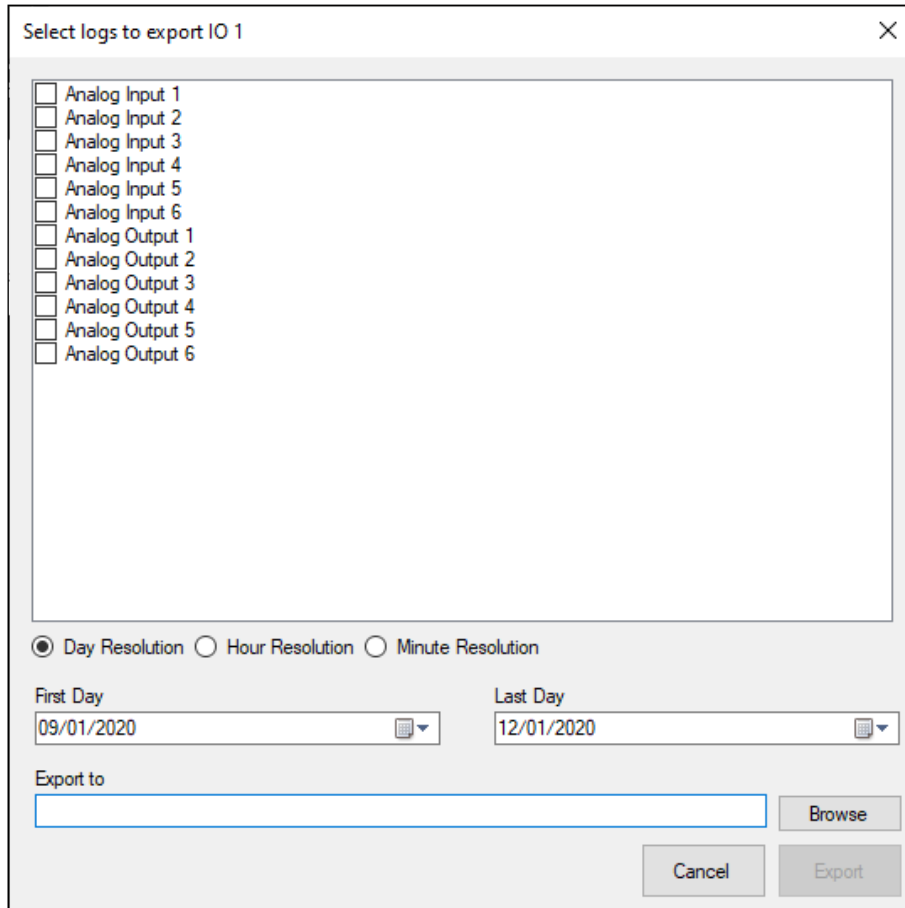

### 8.4. Modbus to BACnet® ProtoNode Gateway

ProtoNode Converter (part # DTICONVBAC) is an external, high performance Building Automation multi-protocol gateway for use with the Mk8 DTI's Modbus protocol to other protocols. These protocols include BACnet®1MS/TP, BACnet/IP and LonWorks®2. Configurations for the various protocols are stored within the ProtoNode and are selectable via DIP switches for fast and easy installation.

It is not necessary to download any configuration files to support the required applications. The ProtoNode is pre-loaded with tested Profiles/Configurations for the supported device.

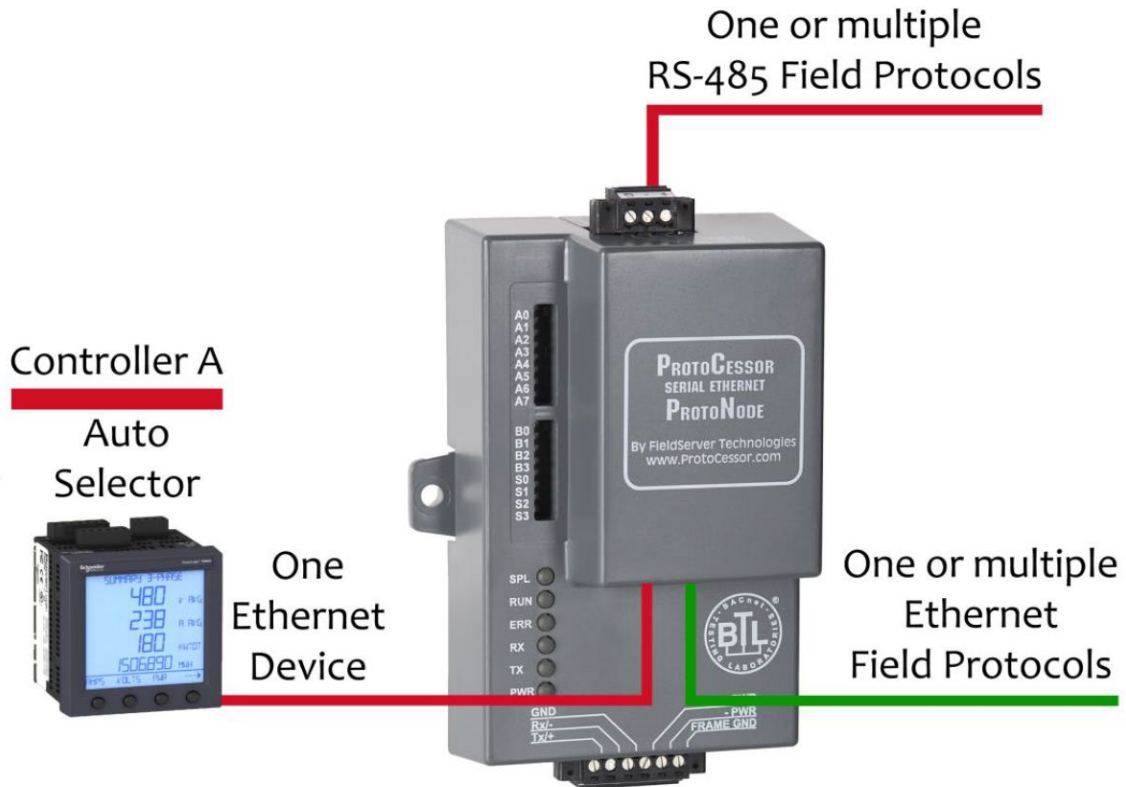

Please contact Autoflame for more information.

## 8.5. Troubleshooting Remote Connection

### Pinging the DTI

To determine the cause of communication failure, pinging the DTI checks that a connection has definitely been established between the computer and DTI.

1. Go to the 'Start Menu' on the computer.
2. In the white search tool box at the bottom (Windows Vista, 7, 8 or 10), type 'cmd' and press enter.
3. In the black command box, type 'ping xxx.xxx.xxx.xxx' where the xxx.xxx.xxx.xxx is the IP address set for the Mk8 DTI on the Network.
4. If there is a successful communication with the DTI, the following information or similar will be seen.

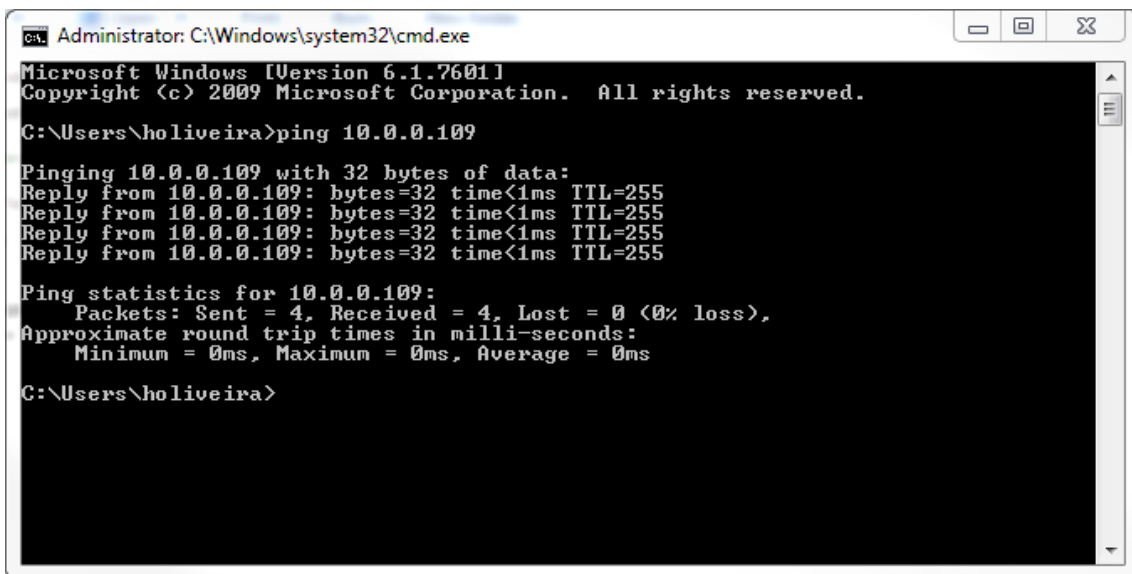

```
ca. Administrator: C:\Windows\system32\cmd.exe
Microsoft Windows [Version 6.1.7601]
Copyright (c) 2009 Microsoft Corporation. All rights reserved.

C:\Users\holiveira>ping 10.0.0.109

Pinging 10.0.0.109 with 32 bytes of data:
Reply from 10.0.0.109: bytes=32 time<1ms TTL=255
Reply from 10.0.0.109: bytes=32 time<1ms TTL=255
Reply from 10.0.0.109: bytes=32 time<1ms TTL=255
Reply from 10.0.0.109: bytes=32 time<1ms TTL=255

Ping statistics for 10.0.0.109:
    Packets: Sent = 4, Received = 4, Lost = 0 (0% loss),
    Approximate round trip times in milli-seconds:
        Minimum = 0ms, Maximum = 0ms, Average = 0ms

C:\Users\holiveira>
```

Figure 8.1.5.i: Pinging the DTI

5. If there is an unsuccessful communication with the DTI, the screen above will not show, instead an error message will appear such as 'Response Timed Out'. Check that the IP configuration is correct, as this is usually caused by incorrect individual configurations.
6. If there is an unsuccessful communication with the DTI and 'DHCP Disabled' is being used, check that the IP address which has been set is available on the network. To set a static IP address that has not been already used, set 'DHCP Enabled'. Then check the IP address that has been issued to the DTI. Next, set 'DHCP Disabled' and set the issued IP address as the static IP address.

## 9. MODBUS

Through the Modbus protocol, the Mk8 DTI data can be read to view boiler room information. The DTI accepts Read and Read/Write commands. The 0x and 4x addresses are the Read/Write commands, and the 1x and the 3x addresses are the Read only commands. The Read/Write commands are those which allow you to control certain aspect of the devices remotely.

### 9.1. Read Only Addresses

#### 9.1.1. DTI

These 3x addresses provide information on the DTI's own Errors and Warnings. They will give a number from a range.

3x Read	Error Status	Error Code	Error Device ID	Warning Status	Warning Code	Warning Device ID
	30001	30002	30003	30004	30005	30006
DTI	0 = No Error 1 = Error	0 = No Error N = Error number	1–10	0 = No Warning 1 = Warning	0 = No Warning N = Warning number	1–10

#### 9.1.2. Pressure Sensors

The 1x read address for the pressure sensors will indicate if the respective sensor is connected or not. They will give out either '0' or '1'.

1x Read	Pressure Sensor ID									
	1	2	3	4	5	6	7	8	9	10
Online Status	11857	11858	11859	11860	11861	11862	11863	11864	11865	11866
	0 = Sensor Online, 1 = Sensor Offline									

The 3x read addresses for the pressure sensors provide the current pressure reading for each sensor connected.

3x Read	Pressure Sensor ID									
	1	2	3	4	5	6	7	8	9	10
Reading	34001	34002	34003	34004	34005	34006	34007	34008	34009	34010
	mbar x 10, "wg x 10, PSI x 100									

### 9.1.3. Mk8 MMs or Mini Mk8 MMs

The 1x addresses are digital input read only addresses, which will give out either '0' or '1'. For example, if Modbus address 10457 outputs 1, this means that MM ID-4 has an EGA optioned.

1x Read	MM ID #									
	1	2	3	4	5	6	7	8	9	10
CR1 Relay Status	10193	10273	10353	10433	10513	10593	10673	10753	10833	10913
	0 = Call for Heat OFF, 1 = Call for Heat ON									
T53 Status	10194	10274	10354	10434	10514	10594	10674	10754	10834	10914
	0 = Running Interlock (T53) is off, 1 = Running Interlock (T53) is on									
Boiler Temp/Pressure	10201	10281	10361	10441	10521	10601	10681	10761	10841	10921
	0 = Temperature, 1 = Pressure									
Flow Metering On	10210	10290	10370	10450	10530	10610	10690	10770	10850	10930
	0 = Flow Metering disabled, 1 = Flow Metering enabled									
Deg C or Deg F	10213	10293	10373	10453	10533	10613	10693	10773	10853	10933
	0 = °C, 1 = °F									
Bar or PSI	10214	10294	10374	10454	10534	10614	10694	10774	10854	10934
	0 = Bar, 1 = PSI									
External Modulation	10215	10295	10375	10455	10535	10615	10695	10775	10855	10935
	0 = Not Optioned, 1 = Optioned									
EGA Trim Optioned	10217	10297	10377	10457	10537	10617	10697	10777	10857	10937
	0 = Not Optioned, 1 = Optioned									
EGA is Trimming	10218	10298	10378	10458	10538	10618	10698	10778	10858	10938
	0 = EGA not trimming, 1 = EGA trimming									
EGA Cooler Ready	10219	10299	10379	10459	10539	10619	10699	10779	10859	10939
	0 = Cooler not Ready, 1 = Cooler Ready									
EGA Ambient Temp OK	10220	10300	10380	10460	10540	10620	10700	10780	10860	10940
	0 = EGA temperature not OK, 1 = EGA temperature OK									
NO2 Optioned	10221	10301	10381	10461	10541	10621	10701	10781	10861	10941
	0 = NO2 cell not optioned, 1 = NO2 cell optioned									
SO2 Optioned	10222	10302	10382	10462	10542	10622	10702	10782	10862	10942
	0 = SO2 cell not optioned, 1 = SO2 cell optioned									
EGA Ambient Temp Hi/Lo	10223	10303	10383	10463	10543	10623	10703	10783	10863	10943
	0 = EGA temperature LOW, 1 = EGA temperature HIGH									
EGA OK to Sample	10224	10304	10384	10464	10544	10624	10704	10784	10864	10944
	0 = EGA is not sampling, 1 = EGA is sampling									
Sequencing Optioned	10225	10305	10385	10465	10545	10625	10705	10785	10865	10945
	0 = Sequencing not optioned, 1 = Sequencing optioned									
Setpoint/ Enable OK	10226	10306	10386	10466	10546	10626	10706	10786	10866	10946
	0 = Setpoint/Enable commands no accepted, 1 = Setpoint/Enable commands accepted									
Hand Operation	10233	10313	10393	10473	10553	10633	10713	10793	10873	10953
	0 = Modulating, 1 = Hand Mode									
Low Flame Hold	10234	10314	10394	10474	10554	10634	10714	10794	10874	10954
	0 = Modulating, 1 = Low Flame Hold									
MM Comms Bus Driver	10239	10319	10399	10479	10559	10639	10719	10799	10879	10959
	0 = MM is not Comms bus driver, 1 = MM is Comms bus driver									

1x Read	MM ID #									
	1	2	3	4	5	6	7	8	9	10
Input 88 Status	10240	10320	10400	10480	10560	10640	10720	10800	10880	10960
	0 = Input not detected, 1 = Input detected									
Lead Boiler Status	10241	10321	10401	10481	10561	10641	10721	10801	10881	10961
	0 = Lag MM, 1 = Lead MM									
Disabled Status	10242	10322	10402	10482	10562	10642	10722	10802	10882	10962
	0 = MM Enabled, 1 = Mm Disabled									
Flame Switch Status	10250	10330	10410	10490	10570	10650	10730	10810	10890	10970
	0 = No flame, 1 = Flame detected									
Online/ Offline Status	11793	11794	11795	11796	11797	11798	11799	11800	11801	11802
	0 = MM Offline, 1 = MM Online									
Water Level Optioned:	12001	12201	12401	12601	12801	13001	13201	13401	13601	13801
	0 = Water Level not optioned, 1 = Water Level optioned									
Imperial (0) or Metric (1)	12002	12202	12402	12602	12802	13002	13202	13402	13602	13802
	0 = Imperial, 1 = Metric									
Feedwater Pump: Off/On	12003	12203	12403	12603	12803	13003	13203	13403	13603	13803
	0 = Pump Off, 1 = Pump On									
TDS: ppm (0), $\mu$ Siemens (1)	12004	12204	12404	12604	12804	13004	13204	13404	13604	13804
	0 = ppm, 1 = $\mu$ S/cm									
WL Ready: No (0), Yes (1)	12005	12205	12405	12605	12805	13005	13205	13405	13605	13805
	0 = No, either water level is not optioned or a water level fault is active									
	1 = Yes, requires water level to be optioned and no water level faults									
TDS Optioned	12006	12206	12406	12606	12806	13006	13206	13406	13606	13806
	0 = TDS not optioned, 1 = TDS optioned									
FO1 State	12007	12207	12407	12607	12807	13007	13207	13407	13607	13807
	0 = First out 1 normal/not active, 1 = First out 1 active									
FO2 State	12008	12208	12408	12608	12808	13008	13208	13408	13608	13808
	0 = First out 2 normal/not active, 1 = First out 2 active									
FO3 State	12009	12209	12409	12609	12809	13009	13209	13409	13609	13809
	0 = First out 3 normal/not active, 1 = First out 3 active									
FO4 State	12010	12210	12410	12610	12810	13010	13210	13410	13610	13810
	0 = First out 4 normal/not active, 1 = First out 4 active									
FO5 State	12011	12211	12411	12611	12811	13011	13211	13411	13611	13811
	0 = First out 5 normal/not active, 1 = First out 5 active									
FO6 State	12012	12212	12412	12612	12812	13012	13212	13412	13612	13812
	0 = First out 6 normal/not active, 1 = First out 6 active									
FO7 State	12013	12213	12413	12613	12813	13013	13213	13413	13613	13813
	0 = First out 7 normal/not active, 1 = First out 7 active									
FO8 State	12014	12214	12414	12614	12814	13014	13214	13414	13614	13814
	0 = First out 8 normal/not active, 1 = First out 8 active									
FO9 State	12015	12215	12415	12615	12815	13015	13215	13415	13615	13815
	0 = First out 9 normal/not active, 1 = First out 9 active									
FO10 State	12016	12216	12416	12616	12816	13016	13216	13416	13616	13816
	0 = First out 10 normal/not active, 1 = First out 10 active									
FO11 State	12017	12217	12417	12617	12817	13017	13217	13417	13617	13817
	0 = First out 11 normal/not active, 1 = First out 11 active									

1x Read	MM ID #									
	1	2	3	4	5	6	7	8	9	10
FO12 State	12018	12218	12418	12618	12818	13018	13218	13418	13618	13818
	0 = First out 12 normal/not active, 1 = First out 12 active									
FO13 State	12019	12219	12419	12619	12819	13019	13219	13419	13619	13819
	0 = First out 13 normal/not active, 1 = First out 13 active									
FO14 State	12020	12220	12420	12620	12820	13020	13220	13420	13620	13820
	0 = First out 14 normal/not active, 1 = First out 14 active									
FO15 State	12021	12221	12421	12621	12821	13021	13221	13421	13621	13821
	0 = First out 15 normal/not active, 1 = First out 15 active									

The 3x addresses are analogue inputs ready only addresses, which will give a number from a range.

For example, if Modbus address 30160 outputs 421, this means that the channel 2 servomotor is at 42.1°.

3x Read	MM ID #									
	1	2	3	4	5	6	7	8	9	10
Firing Rate %	30101	30151	30201	30251	30301	30351	30401	30451	30501	30551
	0 – 100%									
Firing Status	30102	30152	30202	30252	30302	30352	30402	30452	30502	30552
	0 = Non-modulating, 1 = Modulating									
Sequence Status	30103	30153	30203	30253	30303	30353	30403	30453	30503	30553
	0 = On, 1 = Standby, 2 = Warming, 3 = Off									
Burner Rating	30104	30154	30204	30254	30304	30354	30404	30454	30504	30554
	MW x 10									
Actual Value	30105	30155	30205	30255	30305	30355	30405	30455	30505	30555
	Metric: temperature °C, pressure Bar x 10, low pressure Bar x 100 Imperial: Temperature °F, pressure PSI, low pressure PSI x 10									
Required Value	30106	30156	30206	30256	30306	30356	30406	30456	30506	30556
	Metric: temperature °C, pressure Bar x 10, low pressure Bar x 100 Imperial: Temperature °F, pressure PSI, low pressure PSI x 10									
Fuel Selected	30107	30157	30207	30257	30307	30357	30407	30457	30507	30557
	0 = Fuel 1, 1 = Fuel 2, 2 = Fuel 3, 3 = Fuel 4									
Number of Channels	30108	30158	30208	30258	30308	30358	30408	30458	30508	30558
	1 = 2 servomotor channels, 2 = 3 servomotor channels, 3 = 4 servomotor channels									
Channel 1 Position	30109	30159	30209	30259	30309	30359	30409	30459	30509	30559
	Degrees x 10, Range: -6.0° to 96.0°									
Channel 2 Position	30110	30160	30210	30260	30310	30360	30410	30460	30510	30560
	Degrees x 10, Range: -6.0° to 96.0°									
Channel 3 Position	30111	30161	30211	30261	30311	30361	30411	30461	30511	30561
	Degrees x 10, Range: -6.0° to 96.0°									
Channel 4 Position	30112	30162	30212	30262	30312	30362	30412	30462	30512	30562
	Degrees x 10, Range: -6.0° to 96.0°									
MM Error Number	30113	30163	30213	30263	30313	30363	30413	30463	30513	30563
	0 = No Error, N = error code, refer to section 9.3.3									
Multi-Burner ID	30114	30164	30214	30264	30314	30364	30414	30464	30514	30564
	1 – 10									
Run O2	30115	30165	30215	30265	30315	30365	30415	30465	30515	30565
	% x 10									
Run CO2	30116	30166	30216	30266	30316	30366	30416	30466	30516	30566
	% x 10									
Run CO	30117	30167	30217	30267	30317	30367	30417	30467	30517	30567
	ppm x 10									
Run Exhaust Temperature	30118	30168	30218	30268	30318	30368	30418	30468	30518	30568
	Metric: temperature x 10°C, Imperial: temperature x 10°F									
Run Efficiency	30119	30169	30219	30269	30319	30369	30419	30469	30519	30569
	% x 10									
Run NO	30120	30170	30220	30270	30320	30370	30420	30470	30520	30570
	ppm x 10									
Run SO2	30121	30171	30221	30271	30321	30371	30421	30471	30521	30571
	ppm x 10									

3x Read	MM ID #									
	1	2	3	4	5	6	7	8	9	10
Comm. O2	30122	30172	30222	30272	30322	30372	30422	30472	30522	30572
	% x 10									
Comm. CO2	30123	30173	30223	30273	30323	30373	30423	30473	30523	30573
	% x 10									
Comm. CO	30124	30174	30224	30274	30324	30374	30424	30474	30524	30574
	ppm x 10									
Comm. Exhaust Temp.	30125	30175	30225	30275	30325	30375	30425	30475	30525	30575
	Metric: temperature x 10°C, Imperial: temperature x 10°F									
Comm. Efficiency	30126	30176	30226	30276	30326	30376	30426	30476	30526	30576
	% x 10									
Comm. NO	30127	30177	30227	30277	30327	30377	30427	30477	30527	30577
	ppm x 10									
Comm. SO2	30128	30178	30228	30278	30328	30378	30428	30478	30528	30578
	ppm x 10									
EGA Error Number	30129	30179	30229	30279	30329	30379	30429	30479	30529	30579
	0 = No EGA fault, N = error number									
Min. Required Setpoint	30130	30180	30230	30280	30330	30380	30430	30480	30530	30580
	Metric: temperature °C, pressure Bar x 10, low pressure Bar x 100 Imperial: temperature °F, pressure PSI, low pressure PSI x 10									
Max. Required Setpoint	30131	30181	30231	30281	30331	30381	30431	30481	30531	30581
	Metric: temperature °C, pressure Bar x 10, low pressure Bar x 100 Imperial: temperature °F, pressure PSI, low pressure PSI x 10									
Current Flow Thousands	30132	30182	30232	30282	30332	30382	30432	30482	30532	30582
	Metric kW, imperial MMBTU/hr x 1000 Remainder after whole number of MW or MMBTU/hr x 1000 taken away. E.g. 1.5MW gives 500 value and 15.1MMBTU/hr gives 100 value									
Current Flow Millions	30133	30183	30233	30283	30333	30383	30433	30483	30533	30583
	Metric MW, imperial MMBTU/hr Whole number of MW or MMBTU/hr. E.g. 1.5MW gives 1 value and 15.1MMBTU/hr gives 15 value									
Fuel 1 Flow Total Thousands	30134	30184	30234	30284	30334	30384	30434	30484	30534	30584
	Metric kW/hr, imperial MMBTU/hr Remainder after whole number of MW/hr or MMBTU x 1000 taken away, x 1000. E.g. 1.5MW/hr gives 500 value and 15.1MMBTU gives 100 value									
Fuel 1 Flow Total Millions	30135	30185	30235	30285	30335	30385	30435	30485	30535	30585
	Metric MW/h, imperial MMBTU Whole number of MW/hr or MMBTU. E.g. 1.5MW/hr gives 1 value and 15.1MMBTU gives 15 value									
Fuel 1 Flow Total Billions	30136	30186	30236	30286	30336	30386	30436	30486	30536	30586
	Metric GW/hr, imperial MMBTU / 1000 Whole number of GW/hr or MMBTU. E.g. 1.5MW/hr gives 0 value and 15.1MMBTU gives 0 value									
Fuel 2 Flow Total Thousands	30137	30187	30237	30287	30337	30387	30437	30487	30537	30587
	Metric kW/hr, imperial MMBTU/hr – see address 30134 description									
Fuel 2 Flow Total Millions	30138	30188	30238	30288	30338	30388	30438	30488	30538	30588
	Metric MW/h, imperial MMBTU – see address 30135 description									

3x Read	MM ID #									
	1	2	3	4	5	6	7	8	9	10
Fuel 2 Flow Billions	30139	30189	30239	30289	30339	30389	30439	30489	30539	30589
	Metric GW/hr, imperial MMBTU / 1000 – see address 30136 description									
Fuel 3 Flow Thousands	30140	30190	30240	30290	30340	30390	30440	30490	30540	30590
	Metric kW/hr, imperial MMBTU/hr – see address 30134 description									
Fuel 3 Flow Total Millions	30141	30191	30241	30291	30341	30391	30441	30491	30541	30591
	Metric MW/h, imperial MMBTU – see address 30135 description									
Fuel 3 Flow Total Billions	30142	30192	30242	30292	30342	30392	30442	30492	30542	30592
	Metric GW/hr, imperial MMBTU / 1000 – see address 30136 description									
EGA Run Ambient Temp.	30143	30193	30243	30293	30343	30393	30443	30493	30543	30593
	Metric: temperature x 10°C, Imperial: temperature x 10°F									
EGA Run Delta Temp.	30144	30194	30244	30294	30344	30394	30444	30494	30544	30594
	Metric: temperature x 10°C, Imperial: temperature x 10°F									
EGA Comm Ambient Temp	30145	30195	30245	30295	30345	30395	30445	30495	30545	30595
	Metric: temperature x 10°C, Imperial: temperature x 10°F									
EGA Comm Delta Temp.	30146	30196	30246	30296	30346	30396	30446	30496	30546	30596
	Metric: temperature x 10°C, Imperial: temperature x 10°F									
Comm. NO2	30150	30200	30250	30300	30350	30400	30450	30500	30550	30600
	ppm x 10									
Fuel 4 Flow Thousands	30801	30851	30901	30951	31001	31051	31101	31151	31201	31251
	Metric kW/hr, imperial MMBTU/hr – see address 30134 description									
Fuel 4 Flow Total Millions	30802	30852	30902	30952	31002	31052	31102	31152	31202	31252
	Metric MW/h, imperial MMBTU – see address 30135 description									
Fuel 4 Flow Total Billions	30803	30853	30903	30953	31003	31053	31103	31153	31203	31253
	Metric GW/hr, imperial MMBTU / 1000 – see address 30136 description									
Ch5 Output	30804	30854	30904	30954	31004	31054	31104	31154	31204	31254
	mA x 10 or V x 10									
Ch5 Input	30805	30855	30905	30955	31005	31055	31105	31155	31205	31255
	mA x 10 or V x 10									
Ch6 Output	30806	30856	30906	30956	31006	31056	31106	31156	31206	31256
	mA x 10 or V x 10									
Ch6 Input	30807	30857	30907	30957	31007	31057	31107	31157	31207	31257
	mA x 10 or V x 10									
Channel 7 Position	30808	30858	30908	30958	31008	31058	31108	31158	31208	31258
	Degrees x 10, Range: -6.0° to 96.0°									
Lockout Code	30830	30880	30930	30980	31030	31080	31130	31180	31230	31280
	0 = No Lockout, N = Lockout number, refer to section 9.3									
Fuel 1 type	30831	30881	30931	30981	31031	31081	31131	31181	31231	31281
	0 = Gas, 1 = Oil									
Fuel 2 type	30832	30882	30932	30982	31032	31082	31132	31182	31232	31282
	0 = Gas, 1 = Oil									
Fuel 3 type	30833	30883	30933	30983	31033	31083	31133	31183	31233	31283
	0 = Gas, 1 = Oil									
Fuel 4 type	30834	30884	30934	30984	31034	31084	31134	31184	31234	31284
	0 = Gas, 1 = Oil									
Fuel 1 hours run	30839	30889	30939	30989	31039	31089	31139	31189	31239	31289
	Completed hours									

3x Read	MM ID #									
	1	2	3	4	5	6	7	8	9	10
Fuel 2 hours run	30840	30890	30940	30990	31040	31090	31140	31190	31240	31290
	Completed hours									
Fuel 3 hours run	30841	30891	30941	30991	31041	31091	31141	31191	31241	31291
	Completed hours									
Fuel 4 hours run	30842	30892	30942	30992	31042	31092	31142	31192	31242	31292
	Completed hours									
Fuel 1 start-ups	30843	30893	30943	30993	31043	31093	31143	31193	31243	31293
	Number of start-ups									
Fuel 2 start-ups	30844	30894	30944	30994	31044	31094	31144	31194	31244	31294
	Number of start-ups									
Fuel 3 start-ups	30845	30895	30945	30995	31045	31095	31145	31195	31245	31295
	Number of start-ups									
Fuel 4 start-ups	30846	30896	30946	30996	31046	31096	31146	31196	31246	31296
	Number of start-ups									
Air pressure	30847	30897	30947	30997	31047	31097	31147	31197	31247	31297
	mbar x 10, "wg x 10									
Gas pressure	30849	30899	30949	30999	31049	31099	31149	31199	31249	31299
	mbar x 10, "wg x 10, PSI x 100									
MM Error (via DTI)	31301	31302	31303	31304	31305	31306	31307	31308	31309	31310
	MM error code – see section 9.3.1									
MM Lockout (via DTI)	31311	31312	31313	31314	31315	31316	31317	31318	31319	31320
	MM lockout code – see section 9.3.2									
Probe 1 Signal	32001	32101	32201	32301	32401	32501	32601	32701	32801	32901
	Hz reading									
Probe 1 Depth	32002	32102	32202	32302	32402	32502	32602	32702	32802	32902
	Metric: mm, Imperial: inches x 10									
Probe 2 Signal	32005	32105	32205	32305	32405	32505	32605	32705	32805	32905
	Hz reading									
Probe 2 Depth	32006	32106	32206	32306	32406	32506	32606	32706	32806	32906
	Metric: mm, Imperial: inches x 10									
Alarm Status	32009	32109	32209	32309	32409	32509	32609	32709	32809	32909
	0 = No Alarm, 1 = Alarm									
Warning Status	32010	32110	32210	32310	32410	32510	32610	32710	32810	32910
	0 = No Warning, Warning									
Alarm Code	32012	32112	32212	32312	32412	32512	32612	32712	32812	32912
	0 = System is not in Alarm, N = Alarm number									
Warning Code	32013	32113	32213	32313	32413	32513	32613	32713	32813	32913
	0 = System is not in Warning, N = Warning number									
Steam Temp °C	32014	32114	32214	32314	32414	32514	32614	32714	32814	32914
	°C									
Feedwater Temp °C	32015	32115	32215	32315	32415	32515	32615	32715	32815	32915
	°C									
Steam flow Low word (lb/hr)	32016	32116	32216	32316	32416	32516	32616	32716	32816	32916
	Steam Flow = steam flow low word + (65536 x steam flow high word)									
Heat to steam (Btu/lb)	32017	32117	32217	32317	32417	32517	32617	32717	32817	32917
	BTU per lb									

3x Read	MM ID #									
	1	2	3	4	5	6	7	8	9	10
Feed Water Control element	32018	32118	32218	32318	32418	32518	32618	32718	32818	32918
	%									
Sudden Pressure Drop	32020	32120	32220	32320	32420	32520	32620	32720	32820	32920
	0 = Sudden pressure drop not detected, 1 = Sudden pressure drop detected									
Boiler Efficiency	32021	32121	32221	32321	32421	32521	32621	32721	32821	32921
	%, returns 0 if no heat flow is enabled									
Economizer Efficiency	32022	32122	32222	32322	32422	32522	32622	32722	32822	32922
	%, returns 0 if no heat flow is enabled									
Total steam lbs (low word)	32023	32123	32223	32323	32423	32523	32623	32723	32823	32923
	Total steam output = steam low word + (65536 x steam high word)									
Total steam lbs (high word)	32024	32124	32224	32324	32424	32524	32624	32724	32824	32924
	Total steam output = steam low word + (65536 x steam high word)									
Steam Temp °F	32025	32125	32225	32325	32425	32525	32625	32725	32825	32925
	°F									
Feedwater Temp °F	32026	32126	32226	32326	32426	32526	32626	32726	32826	32926
	°F									
Steam Flow Low Word kg/hr	32027	32127	32227	32327	32427	32527	32627	32727	32827	32927
	Steam Flow = steam flow low word + (65536 x steam flow high word)									
Heat to steam KJ/kg	32028	32128	32228	32328	32428	32528	32628	32728	32828	32928
	KJ per hour									
Total steam kgs (low word)	32029	32129	32229	32329	32429	32529	32629	32729	32829	32929
	Total steam output = steam low word + (65536 x steam high word)									
Total steam kgs (high word)	32030	32130	32230	32330	32430	32530	32630	32730	32830	32930
	Total steam output = steam low word + (65536 x steam high word)									
Cold Start status	32037	32137	32237	32337	32437	32537	32637	32737	32837	32937
	0 = System not in cold start mode, 1 = System in cold start mode									
TDS target Value	32040	32140	32240	32340	32440	32540	32640	32740	32840	32940
	Target value in ppm or µS/cm									
TDS measured Value	32041	32141	32241	32341	32441	32541	32641	32741	32841	32941
	Measured value in ppm or µS/cm									
TDS Valve Angle	32044	32144	32244	32344	32444	32544	32644	32744	32844	32944
	Degrees x 10, Range: -6.0° to 96.0°									
Draft Servo Angle	32045	32145	32245	32345	32445	32545	32645	32745	32945	32945
	Degrees x 10, Range: -6.0° to 96.0°									
Draft Actual* Pressure	32046	32146	32246	32346	32446	32546	32646	32746	32946	32946
	mbar x 10, "wg x 10									
Draft Com* Pressure	32047	32147	32247	32347	32447	32547	32647	32747	32947	32947
	mbar x 10, "wg x 10									
Time to Next BBD	32048	32148	32248	32348	32448	32548	32648	32748	32948	32948
	Returns value = (hours x 100) + minutes e.g. 215 is 2 hours 15minutes									
Heat Flow	32049	32149	32249	32349	32449	32549	32649	32749	32949	32949
	Metric: MW x 10, Imperial: MMBTU/hour x 10									
Water Flow	32050	32150	32250	32350	32450	32550	32650	32750	32950	32950
	Metric: Litres per second, Imperial: US gallons per minute									
Ext. WL Sensor Depth	32051	32151	32251	32351	32451	32551	32651	32751	32851	32951
	Metric: mm, Imperial: inches x 10									

3x Read	MM ID #									
	1	2	3	4	5	6	7	8	9	10
2 <sup>nd</sup> Low Probe Input	32052	32152	32252	32352	32452	32552	32652	32752	32852	32952
	0 = No water detected, 1 = Water detected									
Aux High Water Input	32053	32153	32253	32353	32453	32553	32653	32753	32853	32953
	0 = Input not active, 1 = input active									
Aux 1 <sup>st</sup> Low Input	32054	32154	32254	32354	32454	32554	32654	32754	32854	32954
	0 = Input not active, 1 = input active									
Aux 2 <sup>nd</sup> Low Input	32055	32155	32255	32355	32455	32555	32655	32755	32855	32955
	0 = Input not active, 1 = input active									
Combined WL Depth	32056	32156	32256	32356	32456	32556	32656	32756	32856	32956
	Metric: mm, Imperial: inches x 10									
Steam Flow High word lb/hr	32057	32157	32257	32357	32457	32557	32657	32757	32857	32957
	Steam Flow = steam flow low word + (65536 x steam flow high word)									
Steam Flow High Word kg/hr	32058	32158	32258	32358	32458	32558	32658	32758	32858	32958
	Steam Flow = steam Flow low word + (65536 x steam flow high word)									
Excess Air Valid	33001	33101	33201	33301	33401	33501	33601	33701	33801	33901
Excess Air Percent	33002	33102	33202	33302	33402	33502	33602	33702	33802	33902
	%									
Comm. Excess Air Percent	33003	33103	33203	33303	33403	33503	33603	33703	33803	33903
	%									
Fuel Mass Flow 1000s	33010	33110	33210	33310	33410	33510	33610	33710	33810	33910
	Metric: Kg/Hr, Imperial: lb/hr									
Fuel Mass Flow Singles	33011	33111	33211	33311	33411	33511	33611	33711	33811	33911
	Metric: Kg/Hr, Imperial: lb/hr									
Comm. Fuel Mass Flow 1000s	33012	33112	33212	33312	33412	33512	33612	33712	33812	33912
	Metric: Kg/Hr, Imperial: lb/hr									
Comm. Fuel Mass Flow singles	33013	33113	33213	33313	33413	33513	33613	33713	33813	33913
	Metric: Kg/Hr, Imperial: lb/hr									
Fuel Volume Flow 1000s	33014	33114	33214	33314	33414	33514	33614	33714	33814	33914
	Metric: m <sup>3</sup> /hr, Imperial: ft <sup>3</sup> /hr									
Fuel Volume Flow singles	33015	33115	33215	33315	33415	33515	33615	33715	33815	33915
	Metric: m <sup>3</sup> /hr, Imperial: ft <sup>3</sup> /hr									
Flue Flow Meter Current	33016	33116	33216	33316	33416	33516	33616	33716	33816	33916
	mA									
Fuel temperature	33017	33117	33217	33317	33417	33517	33617	33717	33817	33917
	Metric: temperature x 10°C, Imperial: temperature x 10°F									
Fuel Pressure	33018	33118	33218	33318	33418	33518	33618	33718	33818	33918
	mbar x 10, "wg x 10, PSI x 100									
Fuel Channel Correction Fraction	33019	33119	33219	33319	33419	33519	33619	33719	33819	33919
	0 – 100%									
Air Mass Flow 1000s	33020	33120	33220	33320	33420	33520	33620	33720	33820	33920
	Metric: Kg/Hr, Imperial: lb/hr									
Air Mass Flow singles	33021	33121	33221	33321	33421	33521	33621	33721	33821	33921
	Metric: Kg/Hr, Imperial: lb/hr									

3x Read	MM ID #									
	1	2	3	4	5	6	7	8	9	10
Comm. Air Mass Flow 1000s	33022	33122	33222	33322	33422	33522	33622	33722	33822	33922
	Metric: Kg/Hr, Imperial: lb/hr									
Comm. Air Mass Flow singles	33023	33123	33223	33323	33423	33523	33623	33723	33823	33923
	Metric: Kg/Hr, Imperial: lb/hr									
Air Volume Flow 1000s	33024	33124	33224	33324	33424	33524	33624	33724	33824	33924
	Metric: m <sup>3</sup> /hr, Imperial: ft <sup>3</sup> /hr									
Air Volume Flow singles	33025	33125	33225	33325	33425	33525	33625	33725	33825	33925
	Metric: m <sup>3</sup> /hr, Imperial: ft <sup>3</sup> /hr									
Air Flow Meter Current	33026	33126	33226	33326	33426	33526	33626	33726	33826	33926
	mA									
Air Temperature	33027	33127	33227	33327	33427	33527	33627	33727	33827	33927
	Metric: temperature x 10°C, Imperial: temperature x 10°F									
Air Pressure	33028	33128	33228	33328	33428	33528	33628	33728	33828	33928
	mbar x 10, "wg x 10									
Air Channel Correction Fraction	33029	33129	33229	33329	33429	33529	33629	33729	33829	33929
	0 – 100%									
Atmospheric Air Pressure	33030	33130	33230	33330	33430	33530	33630	33730	33830	33930
	Metric: mbar, Imperial: "wg									

\*The draft actual and commissioned pressure values are displayed as the active pressure units.

### 9.1.4. EGAs

The Modbus addresses in this section are used for EGAs connected directly to the MM

The 1x EGA Read addresses give digital inputs. For example, if Modbus address 11002 reads 1, then EGA with ID 1 has an NO cell optioned.

1x Read	EGA ID #									
	1	2	3	4	5	6	7	8	9	10
Air Cal. in Progress	10993	11009	11025	11041	11057	11073	11089	11105	11121	11137
	0 = EGA operates normally, 1 = Air Calibration in progress									
Gas Cal. in Progress	10994	11010	11026	11042	11058	11074	11090	11106	11122	11138
	0 = EGA operates normally, 1 = Gas Calibration in progress									
Cooler Ready	10995	11011	11027	11043	11059	11075	11091	11107	11123	11139
	0 = Cooler not ready, 1 = Cooler ready									
Ambient Temp OK	10996	11012	11028	11044	11060	11076	11092	11108	11124	11140
	0 = Ambient Temperature not OK, 1 = Ambient Temperature OK									
Ambient Temp HIGH	10997	11013	11029	11045	11061	11077	11093	11109	11125	11141
	0 = Ambient Temperature OK, 1 = Ambient Temperature HIGH									
Ambient Temp LOW	10998	11014	11030	11046	11062	11078	11094	11110	11126	11142
	0 = Ambient Temperature OK, 1 = Ambient Temperature LOW									
EGA Ready	11000	11016	11032	11048	11064	11080	11096	11112	11128	11144
	0 = EGA not ready to sample, 1 = EGA ready to sample									
CO Optioned	11001	11017	11033	11049	11065	11081	11097	11113	11129	11145
	0 = CO cell not optioned, 1 = CO cell optioned									
NO Optioned	11002	11018	11034	11050	11066	11082	11098	11114	11130	11146
	0 = NO cell not optioned, 1 = NO cell optioned									
SO <sub>2</sub> Optioned	11003	11019	11035	11051	11067	11083	11099	11115	11131	11147
	0 = SO <sub>2</sub> cell not optioned, 1 = SO <sub>2</sub> cell optioned									
Temperature Unit	11004	11020	11036	11052	11068	11084	11100	11116	11132	11148
	0 = °C, 1 = °F									
Sampling	11005	11021	11037	11053	11069	11085	11101	11117	11133	11149
	0 = EGA not sampling, 1 = EGA sampling									
2 <sup>nd</sup> Thermocouple	11006	11022	11038	11054	11070	11086	11102	11118	11134	11150
	0 = not optioned, 1 = optioned									
NO <sub>2</sub> Optioned	11008	11024	11040	11056	11072	11088	11104	11120	11136	11151
	0 = NO <sub>2</sub> cell not optioned, 1 = NO <sub>2</sub> cell optioned									
Online/ Offline Status	11809	11810	11811	11812	11813	11814	11815	11816	11817	11818
	0 = EGA offline, 1 = EGA online									

The 3x Read addresses give analogue inputs. For example; if Modbus address 30602 outputs reads as 200 then EGA ID 1 has online O<sub>2</sub> value of 2%.

3x Read	EGA ID #									
	1	2	3	4	5	6	7	8	9	10
Fuel Selected	30601	30621	30641	30661	30681	30701	30721	30741	30761	30781
	1 = Fuel 1, 2 = Fuel 2, 3 = Fuel 3, 4 = Fuel4									
Current O <sub>2</sub> Value	30602	30622	30642	30662	30682	30702	30722	30742	30762	30782
	% x 100									
Current CO <sub>2</sub> Value	30603	30623	30643	30663	30683	30703	30723	30743	30763	30783
	% x 100									
Current CO Value	30604	30624	30644	30664	30684	30704	30724	30744	30764	30784
	ppm									
Current NO Value	30605	30625	30645	30665	30685	30705	30725	30745	30765	30785
	ppm									
Current SO <sub>2</sub> Value	30606	30626	30646	30666	30686	30706	30726	30746	30766	30786
	ppm									
Exhaust Temperature	30607	30627	30647	30667	30687	30707	30727	30747	30767	30787
	Metric: temperature x 10 °C, Imperial: temperature x 10 °F									
Efficiency	30608	30628	30648	30668	30688	30708	30728	30748	30768	30788
	% x 10									
Error Code	30609	30629	30649	30669	30689	30709	30729	30749	30769	30789
	0 = EGA des not have fault, N = EGA Error									
Delta Temperature	30611	30631	30651	30671	30691	30711	30731	30751	30771	30791
	Metric: temperature °C, Imperial: temperature °F									
Ambient Temperature	30612	30632	30652	30672	30692	30712	30732	30752	30772	30792
	Metric: temperature °C, Imperial: temperature °F									
Auxiliary Temperature	30613	30633	30653	30673	30693	30713	30733	30753	30773	30793
	Metric: temperature °C, Imperial: temperature °F									
Current NO <sub>2</sub> Value	30615	30635	30655	30675	30695	30715	30735	30755	30775	30795
	ppm									
Ambient Pressure	30616	30636	30656	30676	30696	30716	30736	30756	30776	30796
	Metric: mbar, Imperial: "wg									

### 9.1.5. Input/ Output Modules

The 1x read addresses for the Universal I/O Modules provide information on the status of each I/O Module and also on the status of each digital input. For these addresses a '0' means the output is not active and a '1' means the output is active.

Digital Input	I/O Module ID									
	1	2	3	4	5	6	7	8	9	10
1	10001	10017	10033	10049	10065	10081	10097	10113	10129	10145
2	10002	10018	10034	10050	10066	10082	10098	10114	10130	10146
3	10003	10019	10035	10051	10067	10083	10099	10115	10131	10147
4	10004	10020	10036	10052	10068	10084	10100	10116	10132	10148
5	10005	10021	10037	10053	10069	10085	10101	10117	10133	10149
6	10006	10022	10038	10054	10070	10086	10102	10118	10134	10150
7	10007	10023	10039	10055	10071	10087	10103	10119	10135	10151
8	10008	10024	10040	10056	10072	10088	10104	10120	10136	10152
9	10009	10025	10041	10057	10073	10089	10105	10121	10137	10153
10	10010	10026	10042	10058	10074	10090	10106	10122	10138	10154
11	10011	10027	10043	10059	10075	10091	10107	10123	10139	10155
12	10012	10028	10044	10060	10076	10092	10108	10124	10140	10156
13	10013	10029	10045	10061	10077	10093	10109	10125	10141	10157
14	10014	10030	10046	10062	10078	10094	10110	10126	10142	10158
15	10015	10031	10047	10063	10079	10095	10111	10127	10143	10159
16	10016	10032	10048	10064	10080	10096	10112	10128	10144	10160

	I/O Module ID									
	1	2	3	4	5	6	7	8	9	10
Online/ Offline Status	11825	11826	11827	11828	11829	11830	11831	11832	11833	11834
	0 = Module Offline, 1 = Module Online									
Online/ Offline Status	11841	11842	11843	11844	11845	11846	11847	11848	11849	11850
	0 = Module Offline, 1 = Module Online									

The 3x read addresses for the Universal I/O Modules provide information on the status of each Analogue input. These address display a value within the range of 0 to 255.

Analogue Input #	I/O Module ID									
	1	2	3	4	5	6	7	8	9	10
1	30017	30025	30033	30041	30049	30057	30065	30073	30081	30089
2	30018	30026	30034	30042	30050	30058	30066	30074	30082	30090
3	30019	30027	30035	30043	30051	30059	30067	30075	30083	30091
4	30020	30028	30036	30044	30052	30060	30068	30076	30084	30092
5	30021	30029	30037	30045	30053	30061	30069	30077	30085	30093
6	30022	30030	30038	30046	30054	30062	30070	30078	30086	30094

The 3x read addresses for the Universal I/O Modules provide information on the status of each Analogue input. These address display a value within the range of 0 to 65535.

Analogue Input #	I/O Module ID									
	1	2	3	4	5	6	7	8	9	10
1	31561	31585	31609	31633	31657	31681	31705	31729	31753	31777
2	31562	31586	31610	31634	31658	31682	31706	31730	31754	31778
3	31563	31587	31611	31635	31659	31683	31707	31731	31755	31779
4	31564	31588	31612	31636	31660	31684	31708	31732	31756	31780
5	31565	31589	31613	31637	31661	31685	31709	31733	31757	31781
6	31566	31590	31614	31638	31662	31686	31710	31734	31758	31782

### 9.1.6. Totalized Analogue Inputs

These 3x read only addresses allow to view the Input total for each analogue input.

I/O Module ID		Channel ID					
		1	2	3	4	5	6
1	Byte 7/6	31324	31328	31332	31336	31340	31344
	Byte 5/4	31323	31327	31331	31335	31339	31343
	Byte 3/2	31322	31326	31330	31334	31338	31342
	Byte 1/0	31321	31325	31329	31333	31337	31341
2	Byte 7/6	31348	31352	31356	31360	31364	31368
	Byte 5/4	31347	31351	31355	31359	31363	31367
	Byte 3/2	31346	31350	31354	31358	31362	31366
	Byte 1/0	31345	31349	31353	31357	31361	31365
3	Byte 7/6	31372	31376	31380	31384	31388	31392
	Byte 5/4	31371	31375	31379	31383	31387	31391
	Byte 3/2	31370	31374	31378	31382	31386	31390
	Byte 1/0	31369	31373	31377	31381	31385	31389
4	Byte 7/6	31396	31400	31404	31408	31412	31416
	Byte 5/4	31395	31399	31403	31407	31411	31415
	Byte 3/2	31394	31398	31402	31406	31410	31414
	Byte 1/0	31393	31397	31401	31405	31409	31413
5	Byte 7/6	31420	31424	31428	31432	31436	31440
	Byte 5/4	31419	31423	31427	31431	31435	31439
	Byte 3/2	31418	31422	31426	31430	31434	31438
	Byte 1/0	31417	31421	31425	31429	31433	31437
6	Byte 7/6	31444	31448	31452	31456	31460	31464
	Byte 5/4	31443	31447	31451	31455	31459	31463
	Byte 3/2	31442	31446	31450	31454	31458	31462
	Byte 1/0	31441	31445	31449	31453	31457	31461
7	Byte 7/6	31468	31472	31476	31480	31484	31488
	Byte 5/4	31467	31471	31475	31479	31483	31487
	Byte 3/2	31466	31470	31474	31478	31482	31486
	Byte 1/0	31465	31469	31473	31477	31481	31485
8	Byte 7/6	31492	31496	31500	31504	31508	31512
	Byte 5/4	31491	31495	31499	31503	31507	31511
	Byte 3/2	31490	31494	31498	31502	31506	31510
	Byte 1/0	31489	31493	31497	31501	31505	31509
9	Byte 7/6	31516	31520	31524	31528	31532	31536
	Byte 5/4	31515	31519	31523	31527	31531	31535
	Byte 3/2	31514	31518	31522	31526	31530	31534
	Byte 1/0	31513	31517	31521	31525	31529	31533
10	Byte 7/6	31540	31544	31548	31552	31556	31560
	Byte 5/4	31539	31543	31547	31551	31555	31559
	Byte 3/2	31538	31542	31546	31550	31554	31558
	Byte 1/0	31537	31541	31545	31549	31553	31557

## 9.2. Read/ Write Addresses

### 9.2.1. DTI

The DTI's 4x read/write addresses allow the MM sequence order to be changed via Modbus. Each address represents a position in the sequence. The value read/written from/to each address represents the ID number of an MM. The actual change to the sequence only occurs when there is a valid sequence order (no repeated ID numbers).

	Sequence Position									
	1	2	3	4	5	6	7	8	9	10
DTI	40101	40102	40103	40104	40105	40106	40107	40108	40109	40110
	Range: 1 – 10									

### 9.2.2. Mk8 MMs or Mini Mk8 MMs

These Modbus addresses can be used to remotely control the MMs.

	MM ID #									
	1	2	3	4	5	6	7	8	9	10
Enable/ Disable	00001	00002	00003	00004	00005	00006	00007	00008	00009	00010
	0 = Burner Enabled, 1 = Burner Disabled									
Individual Setpoint	40001	40002	40003	40004	40005	40006	40007	40008	40009	40010
	Metric: temperature °C, pressure Bar x 10, low pressure Bar x 100 Imperial: Temperature °F, pressure PSI, low pressure PSI x 10									
Global Setpoint	40011									
	Metric: temperature °C, pressure Bar x 10, low pressure Bar x 100 Imperial: Temperature °F, pressure PSI, low pressure PSI x 10									
Lead Boiler Selection	40012									
	Range: 1 – 10, MM ID number									
Firing Rate On/ Off	40131	40132	40133	40134	40135	40136	40137	40138	40139	40140
	0 = Internal Firing Rate, 1 = Remote Firing Rate									
Firing Rate Value	40121	40122	40123	40124	40125	40126	40127	40128	40129	40130
	Range: 0 – 100%									

### 9.2.3. Analogue and Digital Outputs

The 0x read/write addresses are digital input/output therefore can only be '0' or '1'. These addresses allow to view and to change the status of each digital output in an I/O Module. For these addresses a '0' means the output is not active and a '1' means the output is active.

Digital Output	Digital I/O Module ID									
	1	2	3	4	5	6	7	8	9	10
1	00017	00025	00033	00041	00049	00057	00065	00073	00081	00089
2	00018	00026	00034	00042	00050	00058	00066	00074	00082	00090
3	00019	00027	00035	00043	00051	00059	00067	00075	00083	00091
4	00020	00028	00036	00044	00052	00060	00068	00076	00084	00092
5	00021	00029	00037	00045	00053	00061	00069	00077	00085	00093
6	00022	00030	00038	00046	00054	00062	00070	00078	00086	00094
7	00023	00031	00039	00047	00055	00063	00071	00079	00087	00095
8	00024	00032	00040	00048	00056	00064	00072	00080	00088	00096

The 4x read /write addresses allow to view and to adjust the status of each analogue output in an I/O Module. These addresses allow to read or write a value in the range of 0 to 255.

Analogue Output	Analogue I/O Module ID									
	1	2	3	4	5	6	7	8	9	10
1	40017	40025	40033	40041	40049	40057	40065	40073	40081	40089
2	40018	40026	40034	40042	40050	40058	40066	40074	40082	40090
3	40019	40027	40035	40043	40051	40059	40067	40075	40083	40091
4	40020	40028	40036	40044	40052	40060	40068	40076	40084	40092
5	40021	40029	40037	40045	40053	40061	40069	40077	40085	40093
6	40022	40030	40038	40046	40054	40062	40070	40078	40086	40094

**9.2.4. Totalized Analogue Inputs**

These 4x read/write addresses allow to view and to adjust the Input totals for each analogue input in an I/O Module. The totals can also be reset via Modbus by setting the respective analogue input total to 0.

I/O Module ID		Analogue Input ID					
		1	2	3	4	5	6
1	Byte 7/6	41324	41328	41332	41336	41340	41344
	Byte 5/4	41323	41327	41331	41335	41339	41343
	Byte 3/2	41322	41326	41330	41334	41338	41342
	Byte 1/0	41321	41325	41329	41333	41337	41341
2	Byte 7/6	41348	41352	41356	41360	41364	41368
	Byte 5/4	41347	41351	41355	41359	41363	41367
	Byte 3/2	41346	41350	41354	41358	41362	41366
	Byte 1/0	41345	41349	41353	41357	41361	41365
3	Byte 7/6	41372	41376	41380	41384	41388	41392
	Byte 5/4	41371	41375	41379	41383	41387	41391
	Byte 3/2	41370	41374	41378	41382	41386	41390
	Byte 1/0	41369	41373	41377	41381	41385	41389
4	Byte 7/6	41396	41400	41404	41408	41412	41416
	Byte 5/4	41395	41399	41403	41407	41411	41415
	Byte 3/2	41394	41398	41402	41406	41410	41414
	Byte 1/0	41393	41397	41401	41405	41409	41413
5	Byte 7/6	41420	41424	41428	41432	41436	41440
	Byte 5/4	41419	41423	41427	41431	41435	41439
	Byte 3/2	41418	41422	41426	41430	41434	41438
	Byte 1/0	41417	41421	41425	41429	41433	41437
6	Byte 7/6	41444	41448	41452	41456	41460	41464
	Byte 5/4	41443	41447	41451	41455	41459	41463
	Byte 3/2	41442	41446	41450	41454	41458	41462
	Byte 1/0	41441	41445	41449	41453	41457	41461
7	Byte 7/6	41468	41472	41476	41480	41484	41488
	Byte 5/4	41467	41471	41475	41479	41483	41487
	Byte 3/2	41466	41470	41474	41478	41482	41486
	Byte 1/0	41465	41469	41473	41477	41481	41485
8	Byte 7/6	41492	41496	41500	41504	41508	41512
	Byte 5/4	41491	41495	41499	41503	41507	41511
	Byte 3/2	41490	41494	41498	41502	41506	41510
	Byte 1/0	41489	41493	41497	41501	41505	41509
9	Byte 7/6	41516	41520	41524	41528	41532	41536
	Byte 5/4	41515	41519	41523	41527	41531	41535
	Byte 3/2	41514	41518	41522	41526	41530	41534
	Byte 1/0	41513	41517	41521	41525	41529	41533
10	Byte 7/6	41540	41544	41548	41552	41556	41560
	Byte 5/4	41539	41543	41547	41551	41555	41559
	Byte 3/2	41538	41542	41546	41550	41554	41558
	Byte 1/0	41537	41541	41545	41549	41553	41557

## 9.3. Fault Codes

### 9.3.1. MM Error Codes

The table below shows the MM Error codes. Please refer to the Mk8 MM / Mini Mk8 MM manual for a full description of the errors.

Code	MK8 MM	Mini MK8 MM
1	Channel 1 Positioning Error	Channel 1 Positioning Error
2	Channel 2 Positioning Error	Channel 2 Positioning Error
3	Channel 3 Positioning Error	Channel 3 Positioning Error
4	Channel 4 Positioning Error	-
5	Channel 7 Positioning Error	Channel 1 Gain Error
6	Channel 1 Gain Error	Channel 2 Gain Error
7	Channel 2 Gain Error	Channel 3 Gain Error
8	Channel 3 Gain Error	-
9	Channel 4 Gain Error	Channel 1 Movement Error
10	Channel 7 Gain Error	Channel 2 Movement Error
11	Channel 1 Movement Error	Channel 3 Movement Error
12	Channel 2 Movement Error	-
13	Channel 3 Movement Error	Analogue Power Supply Error
14	Channel 4 Movement Error	Digital Power Supply Error
15	Channel 7 Movement Error	EEPROM Error
16	Analogue Power Supply Error	ADC Error
17	Digital Power Supply Error	Watchdog Timeout
18	EEPROM Error	Processor Clock Error
19	ADC Error	System Error
20	Watchdog Timeout	Flash Data Error
21	Processor Clock Error	Processor Temperature Error
22	System Error	Burner Control Comms Error
23	Flash Data Error	Burner Control Reset
24	Processor Temperature Error	Software Error
25	Burner Control Comms Error	Zero-Crossing Detection Error
26	Burner Control Reset	Mains Input Detection Error
27	Software Error	Load Sensor Error
28	Zero-Crossing Detection Error	VSD Error
29	Mains Input Detection Error	VSD No Commission Feedback
30	Channel 5 VSD Error	Missing Commissioning Data
31	Channel 6 VSD Error	FAR Execution Speed
32	VSD Feedback Change Too Small	Software Error
33	Missing Commissioning Data	Software Error
34	FAR Execution Speed	Software Error
35	Software Error	Software Error
36	Software Error	VSD Sampling Error
37	Software Error	-
38	Software Error	-
39	VSD Sampling Error	Air Pressure Commission Fault
40	VSD Feedback Too Low	Gas Pressure VPS Commission Fault
41	APS Commission Data Fault	Gas Pressure Run Commission Fault

Code	MK8 MM	Mini MK8 MM
42	Comm VPS Gas Pressure Low	Air Pressure Commission Fault
43	Comm Running Gas Pressure Low	Air Pressure Zeroing Fault
44	Comm Air Pressure Low	-
45	Software Error	-
46	Software Error	-
47	Expansion PF Output (Check F5)	-
48	WL Alarm Output Internal Fault	-
49	Expansion Servo Hardware Fault	-
50	Triac Power Supply Error (Check F2)	-
51	Fused 12V Supply Error (Check F4)	-
52	Fused 13.5V Supply Error (Check F3)	-
53	Air Pressure Zeroing Fault	-
54	Software error	-
55	Software error	-
56	Software error	-
57	Software error	-
58	Software error	-
59	Software error	-
60	Software error	-
61	Software error	-
62	Software error	-
63	Software error	-
64	ADC Reference Voltage Error	-
65	Software error	-
66	Software error	-
67	Software error	-

### 9.3.2. Lockout Codes

The table below shows the MM Lockout codes. Please refer to the Mk8 MM / Mini Mk8 MM Manual for a full description of the lockouts.

Lockout	MK8 MM	Mini MK8 MM
1	CPI Input Wrong State	CPI Input Wrong State
2	No Air Proving	No Air Proving
3	Ignition Output Fault	Ignition Output Fault
4	Motor Output Fault	Motor Output Fault
5	Start Gas Output Fault	Start Gas Output Fault
6	Main Gas 1 Output Fault	Main Gas 1 Output Fault
7	Main Gas 2 Output Fault	Main Gas 2 Output Fault
8	Vent Valve Output Fault	Vent Valve Output Fault
9	Failsafe Relay (Check F1)	Failsafe Relay (Check 5AT)
10	Simulated Flame	Simulated Flame
11	VPS Air Proving Fail	VPS Valve 1 Proving Fail
12	VPS Gas Proving Fail	VPS Valve 2 Proving Fail
13	No Flame Signal	No Flame Signal
14	Shutter Fault	Shutter Fault
15	NO CPI Reset	NO CPI Reset
16	Prolonged Lockout Reset	-
17	Gas Pressure Low	Gas Pressure Low
18	Gas Pressure High	Gas Pressure High
19	RAM Test Failed	RAM Test Failed
20	PROM Test Failed	PROM Test Failed
21	FSR Test 1A	FSR Test 1A
22	FSR Test 2A	FSR Test 2A
23	FSR Test 1B	FSR Test 1B
24	FSR Test 2B	FSR Test 2B
25	Watchdog Fail 2A	-
26	Watchdog Fail 2B	Watchdog Fail 2B
27	Watchdog Fail 2C	-
28	Watchdog Fail 2D	Watchdog Fail 2D
29	Input Fault	Input Fault
32	Gas Pressure Low Limit	Gas Pressure Low Limit
33	VPS Air Zeroing	VPS Pressure Zeroing
36	Oil Pressure Too Low	-
37	Oil Pressure Too High	-
39	Freeze Timeout	Freeze Timeout
40	Purge Air Pressure Low	-
42	Terminal 86 Inverse	-
43	Terminal 85/86 Fault	-
44	Proving Circuit Fail T52	Proving Circuit Fail T80
45	No Proving Circuit Set	No Proving Circuit Set T80
46	Proving Interlock Timeout	Purge Pressure Proving Timeout
47	-	Ion. Internal Failsafe Fault
48	-	Ion. Positive Peak Failsafe Fault
49	-	Ion. Negative Peak Failsafe Fault

Lockout	MK8 MM	Mini MK8 MM
50	-	Simulated Flame
51	-	No Flame Signal
52	High IR Ambient	High IR Ambient
53	IR Comms Lost	IR Comms Lost
54	Watchdog Long X A	-
55	Watchdog Long Y A	-
56	Watchdog Off A	-
57	Watchdog Short X B	-
58	Watchdog Short Y B	-
59	Watchdog Long X B	-
60	Watchdog Long Y B	-
61	Watchdog Off B	-
62	UV Signal Too High	UV Signal Too High
63	Purge Limit Switch	Purge Limit Switch
64	Start Limit Switch	Start Limit Switch
65	FSR A	FSR A
66	FSR B	FSR B
67	Gas Sensor Comms	Gas Sensors Comms
68	Gas Sensor Type	Gas Sensor Type
69	Gas Sensor Fault	Gas Sensor Fault
70	UV Pot Fault	UV Pot Fault
71	Air Sensor Comms	Air Sensor Comms
72	Air Sensor Type	Air Sensor Type
73	Air Sensor Fault	Air Sensor Fault
74	Air Sensor Zero	Air Sensor Zero
75	Air Sensor Signal High	Air Sensor Signal High
76	Air Sensor Error Window	Air Sensor Error Window
77	Wait Air Switch Timeout	Wait Air Switch Timeout
78	Gas Proving Fail High	Gas Proving Fail High
79	FSR Test 1C	FSR Test 1C
80	Timeout on Reaching Purge	Timeout on Reaching Purge
81	Oil Pressure Sensor Fault	-
82	Purge Pressure Proving Input	Purge Pressure Proving Input
198	BC Input Short	BC Input Short
199	Lockout 199	Lockout 199
200	Lockout Cleared	Lockout Cleared
201	Power up CPU Test Fail	Power up CPU Test Fail
202	Power up EEPROM Test Fail	Power up EEPROM Test Fail

### 9.3.3. Alarms and Warnings

For the MK8 MM, Alarms and Warnings are faults detected with the system operation. Whether these faults are reported as Alarms or Warnings is dependent on the following settings.

Option 13	EGA Fault Response
Option 14	Warning Response
Expansion Option 9	Burner Operation at High Water
Expansion Option 20	Burner Operation on Feedwater Control Fault
Expansion Option 88	Action on Pressure Sensor Fault

For the Mini Mk8 MM only EGA Error apply due to the reduced number of functionalities available. In the Mini Mk8 Mm Option 13 determines the response to an EGA fault.

The table below shows the MM Alarm codes. Please refer to the Mk8 MM / Mini Mk8 MM manual for full description of the faults.

Fault	Mk8 MM	Mini MK8 MM
1	EGA Internal Error	EGA Internal Error
2	No EGA Communications	No EGA Communications
3	O <sub>2</sub> Upper Limit	O <sub>2</sub> Upper Limit
4	O <sub>2</sub> Absolute Limit	O <sub>2</sub> Absolute Limit
5	O <sub>2</sub> Lower Limit	O <sub>2</sub> Lower Limit
6	CO <sub>2</sub> Upper Limit	CO <sub>2</sub> Upper Limit
7	CO <sub>2</sub> Absolute Limit	CO <sub>2</sub> Absolute Limit
8	CO <sub>2</sub> Lower Limit	CO <sub>2</sub> Lower Limit
9	CO Upper Limit	CO Upper Limit
10	CO Absolute Limit	CO Absolute Limit
11	NO Upper Limit	NO Upper Limit
12	Exhaust Temperature Upper Limit	Exhaust Temperature Upper Limit
13	Exhaust Temperature Absolute Limit	Exhaust Temperature Absolute Limit
50	Load Sensor Fault	-
51	Auxiliary Input Low	-
80	Oil Pressure Sensor Fault	-
100	Cap Probe 1 Communications Fault	-
101	Cap Probe 2 Communications Fault	-
102	Cap Probe 1 Short Circuit	-
103	Cap Probe 2 Short Circuit	-
104	Cap Probe 1 Temp Compensation Error	-
105	Cap Probe 2 Temp Compensation Error	-
106	Cap Probe 1 Still Water Detected	-
107	Cap Probe 2 Still Water Detected	-
108	Cap Probe 1 Serial Number Mismatch	-
109	Cap Probe 2 Serial Number Mismatch	-
110	Cap Probe 1 Detected But Not Optioned	-
111	Cap Probe 2 Detected But Not Optioned	-
112	External Level Sensor Input Low	-
113	Probe Reading Mismatch	-
114	Probe Serial Numbers are the Same	-
120	Aux WL Inputs Mismatch	-
121	Water Levels Diverse	-
122	Permanent Alarm Reset Input	-

Fault	Mk8 MM	Mini MK8 MM
123	Second Low Probe Communications Fault	-
124	Second Low Probe Hardware Fault	-
125	Permanent Test Input	-
126	Second Low Probe Detected But Not Optioned	-
127	Aux WL Inputs Detect But Not Optioned	-
130	Feed Water Servo Position Error	-
131	Feed Water Servo Movement Error	-
150	High Water	-
151	Pre-High Water	-
152	Pre-1 <sup>st</sup> Low	-
153	1 <sup>st</sup> Low	-
154	2 <sup>nd</sup> Low	-
155	Shunt Switch Time Expired	-
200	Top Blowdown Sensor Communications Fault	-
201	Top Blowdown Servo Position Error	-
202	Top Blowdown Servo Movement Error	-
250	Top Blowdown Reading High	-
300	Bottom Blowdown Controller Comms	-
301	Bottom Blowdown Controller Software Fault	-
302	Bottom Blowdown Servo Closing Fault	-
303	Bottom Blowdown Servo Opening Fault	-
304	Bottom Blowdown Servo Battery Drive Fault	-
305	Bottom Blowdown Controller Main Power Fault	-
350	Bottom Blowdown Servo Not Commissioned	-
400	Draught Pressure Sensor Timeout	-
410	Draught Pressure Outside Tolerance	-
420	Fuel flow Feedback Input Low	-
430	Fuel flow Feedback Below Tolerance	-
431	Fuel flow Feedback Above Tolerance	-
440	Temperature Sensor T1Fault	-
441	Temperature Sensor T2 Fault	-
442	Temperature Sensor T3 Fault	-
443	Make Up Flow Meter Fault	-
444	Condensate Flow Meter Fault	-
445	Deaerator IO Comms Fault	-
500	Multi-Burner Communications Fault	-
501	Multi-Burner Version Mismatch	-
502	Multi-Burner Not Polled	-
503	Multi-Burner Config (Multi-Burner Mode)	-
504	Multi-Burner Config (Fuel Index)	-
505	Multi-Burner Config (Fuel Type)	-
506	Multi-Burner Config (Pilot Type)	-
507	Multi-Burner Config (Load Sensor)	-
550	Fuel Flow Meter Fault	-
551	Air Flow Meter Fault	-
552	Fuel Temperature Sensor Fault (T2)	-
553	Air Temp Sensor Fault (T3)	-

Fault	Mk8 MM	Mini MK8 MM
554	Fuel Pressure Sensor Fault	-
555	Air Pressure Sensor Fault	-
560	Fully Metered Air Adjustment Failure	-
580	Servo Control I/O Unit Communications Fault	-
581	Servo Control I/O Unit Channel 1 Output Fault	-
582	Servo Control I/O Unit Channel 2 Output Fault	-
583	Servo Control I/O Unit Channel 3 Output Fault	-
584	Servo Control I/O Unit Channel 4 Output Fault	-
585	Servo Control I/O Unit Channel 7 Output Fault	-
586	Servo Control I/O Unit Channel 1 Input Fault	-
587	Servo Control I/O Unit Channel 2 Input Fault	-
588	Servo Control I/O Unit Channel 3 Input Fault	-
589	Servo Control I/O Unit Channel 4 Input Fault	-
590	Servo Control I/O Unit Channel 7 Input Fault	-

## 10. TROUBLESHOOTING

### 10.1. Errors and Warnings

The DTI's Errors and Warnings reports malfunction of the equipment being monitored by the DTI. DTI's setting 11 selects how the alarm output terminal operates on the occurrence of a fault. Whether these faults generate Errors or Warnings depends on the following settings:

Boiler Setting 4	Action on MM communications failure
Boiler Setting 5	Action on EGA communications failure
IO Module Setting 3	Action on IO Module communications failure
Pressure Sensor Setting 9	Actions on Pressure Sensor communications failure
Pressure Sensor Settings 5 and 8	High and Low pressure level Error limits
Pressure Sensor Setting 6 and 7	High and Low Pressure level Warning limits
Rules System Setting 7	Output Selection, when rule is configured to generate a DTI fault

Fault	Message	Description
1	Log Write Failure	DTI failed to save data to the SD card.
	<ul style="list-style-type: none"> <li>Power the DTI off/on</li> <li>Replace the SD card (do not format)</li> </ul>	
2	Pressure Sensor 'ID' Reading High	Pressure reading of the respective Pressure sensor exceeds the higher error/warning limit
	<ul style="list-style-type: none"> <li>Check Air/Gas pressure</li> <li>Check Pressure sensor setting 5 if error or setting 6 if warning</li> </ul>	
3	Pressure Sensor 'ID' Reading Low	Pressure reading of the respective Pressure sensor exceeds the lower error/warning limit
	<ul style="list-style-type: none"> <li>Check Air/Gas pressure</li> <li>Check Pressure sensor setting 7 if warning or setting 8 if error</li> </ul>	
4	Pressure Sensor 'ID' Communications Failure	DTI not able to establish communications with the respective Pressure sensor
	<ul style="list-style-type: none"> <li>Check wiring between respective Pressure sensor and DTI</li> </ul>	
5	IO Module 'ID' Communications Failure	DTI not able to establish communications with the respective IO module
	<ul style="list-style-type: none"> <li>Check wiring between respective IO module and DTI</li> </ul>	
6	MM 'ID' Communications Failure	DTI not able to establish communications with the respective MM
	<ul style="list-style-type: none"> <li>Check wiring between respective MM and DTI</li> </ul>	
7	EGA 'ID' Communications Failure	DTI not able to establish communications with the respective EGA
	<ul style="list-style-type: none"> <li>Check wiring between respective EGA and DTI</li> </ul>	
8	Lead Boiler Rotation Prevented by MM	Scheduled lead boiler rotation did not take place because lead boiler selection has been overridden
	<ul style="list-style-type: none"> <li>Check which MM has either the Lead-boiler select soft button or switch activated</li> </ul>	
9	MM 'ID' Not Ready to Become Lead Boiler	MM scheduled to become lead boiler was not ready. Respective MM has been skipped over.
	<ul style="list-style-type: none"> <li>Check if respective MM is in fault or interlock is not made</li> </ul>	
10	Rule Fault 'ID'	Fault generated by the Rules System
	<ul style="list-style-type: none"> <li>Check Rules system screen to determine the cause of fault</li> </ul>	
11	Change of EGA with Id 'ID' detected	New EGA detected with same ID as another EGA previously connected.
	<ul style="list-style-type: none"> <li>If a certain EGA has been replaced use 'EGA Changeover' screen to tell the DTI to accept the new EGA.</li> </ul>	

## 10.2. Device Conflicts

Device conflict messages prompt the user to discrepancies in the sequencing settings in the MMs and also operational units between EGAs and DTI and between MMs and DTI.

Device	Conflict
MM 'ID'	Units setting does not match DTI <ul style="list-style-type: none"> <li>• MM units (Metric/Imperial) do not match units selected in the DTI</li> <li>• Check MM Parameter 40</li> <li>• Check DTI Setting 8</li> </ul>
MM 'ID'	Load sensor type does not match Global Setpoint <ul style="list-style-type: none"> <li>• MM load sensor type does not match Global Setpoint Type</li> <li>• Check MM Option 1</li> <li>• Check DTI Setting 80</li> </ul>
MM 'ID'	Load Sensor type does not match on all sequencing MMs <ul style="list-style-type: none"> <li>• Load Sensor type (temperature/pressure) is not the same for all the MMs in the sequencing loop</li> <li>• Check MM Option 1</li> </ul>
MM 'ID'	Global Setpoint specified, MM not optioned to accept DTI commands <ul style="list-style-type: none"> <li>• DTI control has not been enabled in the respective MM</li> <li>• Check MM Option 16</li> </ul>
MM 'ID'	DTI Setpoint specified, MM not optioned to accept DTI commands <ul style="list-style-type: none"> <li>• DTI control has not been enabled in the respective MM</li> <li>• Check MM Option 16</li> </ul>
MM 'ID'	DTI firing rate specified, MM not optioned to accept DTI commands <ul style="list-style-type: none"> <li>• DTI control has not been enabled in the respective MM</li> <li>• Check MM Option 16</li> </ul>
MM 'ID'	MM disabled by DTI, MM not optioned to accept DTI commands <ul style="list-style-type: none"> <li>• DTI control has not been enabled in the respective MM</li> <li>• Check MM Option 16</li> </ul>
MM 'ID'	Non-return valve setting does not match on all sequencing MMs <ul style="list-style-type: none"> <li>• Non-return valve setting is not the same for all the MMs in the sequencing loop</li> <li>• Check MM Option 40</li> </ul>
MM 'ID'	Modulation timeout does not match on all sequencing MMs <ul style="list-style-type: none"> <li>• Modulation timeout setting is not the same for all the MMs in the sequence loop</li> <li>• Check MM Parameter 5</li> </ul>
MM 'ID'	Highest MM ID not high enough for optioned MMs <ul style="list-style-type: none"> <li>• Highest MM ID setting on the respective MM is not high enough to communicate with all enabled MMs</li> <li>• Check MM Parameter 57</li> </ul>
MM 'ID'	Hot Water sequencing type does not match on all sequencing MMs <ul style="list-style-type: none"> <li>• Selected sequencing type is not the same for all the MMs in the sequencing loop</li> <li>• Check MM Parameter 62</li> </ul>
MM 'ID'	Sequencing change thresholds do not match on all sequencing MMs <ul style="list-style-type: none"> <li>• Sequencing Change Up/Down thresholds are not set the same for all the MM in the sequencing loop</li> <li>• Check MM Parameters 86 and 87</li> </ul>
MM 'ID'	Shuffle sequencing should be enabled with Mk8 DTI <ul style="list-style-type: none"> <li>• To use sequencing and DTI's Lead boiler control, shuffle sequencing has to be enabled</li> <li>• Check MM Parameter 101</li> </ul>
MM 'ID'	Global setpoint specified, MM using Outside Temperature Compensation <ul style="list-style-type: none"> <li>• Global Setpoint selected for the respective MM in the Setpoint control screen. Respective MM is configured to use Outside Temperature Compensation which overrides DTI's setpoint control</li> <li>• Check changes to the Setpoint Control screen on the DTI</li> <li>• Check MM Option 80</li> </ul>

Device	Conflict
MM 'ID'	DTI setpoint specified, MM using Outside Temperature Compensation <ul style="list-style-type: none"><li>• DTI Setpoint selected for the respective MM in the Setpoint control screen. Respective MM is configured to use Outside Temperature Compensation which overrides DTI's setpoint control</li><li>• Check changes to the Setpoint Control screen on the DTI</li><li>• Check MM Option 80</li></ul>
EGA 'ID'	Units setting does not match DTI <ul style="list-style-type: none"><li>• EGA units (Metric/Imperial) do not match units selected in the DTI</li><li>• Check EGA Setting 3 and DTI Setting 8</li></ul>

**MK8 DTI MANUAL**  
**DTI80100**  
**29.07.2020**

Autoflame Engineering Ltd.  
Unit 1-2, Concorde Business Centre  
Airport Industrial Estate, Wireless Road  
Biggin Hill, Kent TN16 3YN  
United Kingdom

Tel: +44 (0)1959 578 820  
Email: [technicalsupport@autoflame.com](mailto:technicalsupport@autoflame.com)  
Website: [www.autoflame.com](http://www.autoflame.com)

