

243 Service Regulators

Installation and Maintenance Instructions

Introduction

The 243 is a large capacity, general-purpose gas pressure regulator.

Its outstanding performance and versatility make it an excellent choice for use on industrial meter sets, combustion equipment, boilers, unit heaters, furnaces, ovens and other applications.

Use it for natural gas, air dry CO₂, propane, butane, LPG, nitrogen, and others. Special materials are available for certain corrosive gases.

In addition to the standard models and internal relief models covered in this bulletin, the 243 is also available with low pressure cut-off, with built-in monitor, and as a pilot operated regulator (outlet pressures to 35 psig), a back pressure valve, a relief valve, a vacuum regulator and a vacuum breaker. For information, please contact your Sensus sales office or authorized industrial distributor. The 243 is manufactured in conformance with Code B31.8.

NOTE: The term “standard” refers to non-IRV configurations.

Model Specifications

243-12-1 and 243-12-2

Maximum Inlet Pressure 125 psi
 Outlet Pressures 3½" w.c. to 3 psi
 Pipe Sizes 1¼", 1½" and 2"
 Diaphragm 12" (nominal diameter)

243-8-1 and 243-8-2

Maximum Inlet Pressure 125 psi
 Outlet Pressures 3½" w.c. to 4¼" psi
 Pipe Sizes 1¼", 1½" and 2"
 Diaphragm 8" (nominal diameter)

243-8HP

Maximum Inlet Pressure 125 psi
 Outlet Pressures 3 to 10 psi
 Pipe Sizes 1¼", 1½" and 2"
 Diaphragm 8" (nominal diameter)

Maximum Inlet Pressure

243-12	Orifice Size-Value	243-8
15 psi	1¼"-30°	—
25 psi*	1¼"-10°	—
25 psi	1"-30°	25 psi
40 psi*	1"-10°	25 psi
40 psi	¾"-30°	40 psi
60 psi†	¾"-10°	40 psi
100 psi	½"-10°	80 psi
125 psi	¾"-10°	100 psi
125 psi	¼"-10°	125 psi
—	.207"-10°	125 psi

*Applies only to 243-12 with external control line.

†80 psi for 243-12 with external control line.

Temperature Limits

Model 243 Service Regulators can be used for flowing temperatures from -20°F to 150°F.

Buried Service

Model 243 Service Regulators are **not** recommended for buried service.

Installation and Start up

(See illustrations on page 4.)

1. Make certain that the regulator and piping are free of dirt, moisture, foreign matter and other debris.
2. Be sure all shipping screens or covers are removed and the regulator is installed with flow in the correct direction.
3. The regulator may be installed in any position—right side up, upside down, vertical pipe, horizontal pipe, diagonal pipe, etc.

By loosening union bolts (16), the diaphragm case assembly may be rotated to various positions in relation to the body. Make certain union bolts (16) are retightened to hold diaphragm case assembly in new position and to reseal.



CAUTION

The diaphragm case vent must be positioned to protect against flooding, drain water, ice formation, traffic, tampering, etc. The vent must be protected against nest building animals, bees, insects, etc. to prevent vent blockage and minimize the chances for foreign material from collecting in the vent side of the regulator diaphragm.

4. Make sure there are no leaks and all connections are firm and tight. Tighten flange bolts evenly and firmly. On screwed connections, apply pipe dope to male threads only.
5. On regulators that are arranged for an external control line, run pipe or tubing from a ½" NPT connection in the lower case to the control connection in the outlet piping. This control piping should not be less than ½" in size and should be adequately protected against breakage (regulators go wide open if the control line is broken). In general, the control connection should be at least 8 pipe diameters from the regulator and in as straight a run of pipe as possible. The connection itself must be smooth on the inside of the pipe. Pitch the control line away from the regulator and avoid moisture pockets. Keep the inside of the control line clean. Never install any type of automatic shutoff device, which closes completely, between the regulator outlet and the control line connection.



CAUTION

It is the user's responsibility to assure that all regulator vents and/or vent lines exhaust to a non-hazardous location away from any potential sources of ignition. Where vent line are used, it is the user's responsibility to assure that each service regulator is individually vented and that common vent lines are not used.

6. Adjust outlet pressure (setpoint) by removing cap **(1)** or **(1e)** and turning adjustment spring button **(3)**. On the 243-8HP, remove cap **(1a)**, loosen locknut and turn adjustment screw **(1b)**. Turn clockwise to increase and counterclockwise to decrease outlet pressure. Only adjust when gas is flowing through the regulator. When adjustment is completed, seal cap **(1)** or **(1e)** must be securely screwed into place. The absence of this seal cap can result in unstable operation.
7. On regulators with an internal relief valve (IRV), there is no adjustment for the internal relief. It is fixed, with relief beginning at approximately 9" w.c. to 20" w.c., above regulator setpoint, depending on relief spring **(11k)** used.

Internal relief valves must be carefully sized. For information, contact your Sensus representative.
8. Regulators installed indoors must be vented outside. Run vent pipe from the regulator vent connection to a safe place outside. Vent piping should be as short and direct as possible.

Vent piping for regulators with an internal relief valve (Models 243-12-2 or 243-8-2) must be large enough to vent all relief valve discharge to atmosphere without excessive back pressure and resulting excessive pressure in the regulator.

The vent pipe outlet must be protected against nest building animals, bees, insects, etc., and positioned to protect against flooding, drain water, ice formation, etc. but must allow free and unobstructed passage of air or gas.



CAUTION

Turn gas on very slowly. If an outlet stop valve is used, it should be opened first. Do not overload the diaphragm with a sudden surge of inlet pressure. Monitor the outlet pressure during start-up to prevent an outlet pressure overload.

Servicing

1. Make sure the regulator is entirely depressured before disassembling.
2. Carefully note the location and position of all disassembled parts to be certain that reassembly is correct. Inspect each part and replace those that are worn or damaged or otherwise unsatisfactory.
3. For access to valve **(21)** and orifice **(24)** loosen union bolts **(16)** and remove the diaphragm case assembly from the body.

To remove valve **(21)**, first remove hair pin cotter **(20b)**.

Orifice **(24)** unscrews from the body. Use 1 $\frac{5}{8}$ " hex socket "thinwall" type. When replacing the orifice, use a moderate amount of pipe dope on orifice threads.
4. Before reassembling and tightening union bolts **(16)**, make certain Tetraseal **(17)** is in position.
5. To replace diaphragm, remove spring **(4)**, remove flange bolts **(8)** and nuts **(9)**, and disassemble diaphragm assembly. Remove old diaphragm **(11a)**, from diaphragm pan **(11b)**. Remove old adhesive from the diaphragm pan using a solvent such as methyl ethyl ketone (MEK).

To reassemble, apply a thin, even layer of a rubber based adhesive such as 3M Industrial Adhesive #EC-847 to the cleaned, prepared side of the diaphragm pan.

Attach the diaphragm to the adhesive side of the diaphragm pan, being careful to align the center hole of the diaphragm with the corresponding center hole in the diaphragm pan. Make certain all parts are reassembled in their correct order and bolts **(8)** are tightened to a torque of 150 in-lbs. Bolts must be tight enough to prevent leakage but not too tight that the diaphragm material is crushed or damaged. The diaphragm must not be twisted or pinched.
6. Upon completion of servicing, make certain that the regulator installation is entirely free of leaks.



CAUTION

Regulators are pressure control devices with numerous moving parts subject to wear that is dependent upon particular operating conditions. To assure continuous satisfactory operation, a periodic inspection schedule must be adhered to with the frequency of inspection determined by the severity of service and applicable laws and regulations.

Condensed Parts List

The following are the parts generally required in maintenance and servicing.
For a complete list of parts refer to Parts List PL-G-REG-1306.

Illustration Number	Description	Part Number
1	Cover Cap (IRV)	143-16-005-00
1e	Cover Cap (STD)	143-16-005-08
1d	Tetraseal, 1½" x 1½"	906534
2	O-Ring #2-140	951357
2a	O-Ring #2-142	951376
3	Adjustment Spring Button	143-16-009-00
4	Spring (See table, page 5)	
5	243-12 Cover Assembly IRV (includes vent valve and spring)	143-16-503-03
	243-12 Cover Assembly STD (includes vent valve and spring)	143-16-503-19
	243-8 Cover Assembly (includes vent valve and spring)	143-82-503-04
8	Flange Bolt, ⅝" x 1" Hex Hd.	910030
9	Flange Nut, ⅝"-18 Hex S.F.	921002
10	243-12 Lower Case	143-16-002-00
	243-12 Lower Case (tapped for external control line)	143-16-002-01
	243-08 Lower Case	143-82-002-00
	243-08 Lower Case (tapped for external control line)	143-82-002-01
11a*	243-12 Diaphragm	143-16-150-00
	243-8 Diaphragm	143-82-150-00
	243-8HP Diaphragm	121-10-150-50
11b	243-12 Diaphragm Pan	143-16-017-00
	243-8 Diaphragm Pan	143-82-017-00
	243-8HP Diaphragm Pan	121-10-017-50
11d*	Seal Washer	143-16-115-00
11e	Emory Cloth Washer (faces against top side of 243-8HP diaphragm)	143-82-178-00
11f	Spring Guide	143-16-018-00
	Spring Guide (243-8HP)	121-10-022-53

*Denotes recommended spare parts

Illustration Number	Description	Part Number
11k	Internal Relief Valve Spring, for 243-8-2 only. (relief begins at approx. 9" w.c. above regulator setpoint)	143-82-021-03
11k	Internal Relief Valve Spring, (relief begins at approx. 9" w.c. for 243-12-2, and approx. 20" w.c for 243-8-2 above regulator setpoint)	143-16-021-02
11s	243-8HP Diaphragm Plate	121-10-022-52
13*	243-12 Coupling-Lever-Stem Assembly	143-16-530-00
	243-8 Coupling-Lever-Stem Assembly	143-82-530-02
	243-8HP Coupling-Lever-Stem Assembly	143-82-530-02
16	Union Bolts, ⅜" x 1¼" Hex	910056
17*	Tetraseal (or O-Ring) 2¼" x 2½"	904075
18*	243-8 Throat Block with O-Ring Seal	143-16-508-00
	243-12 Throat Block with O-Ring Seal	143-16-508-04
20b	Hair Pin Cotter	143-62-118-00
21*	Valve Assembly - 10° - Buna N	143-16-511-09
	Valve Assembly - 10° - Viton	143-16-511-11
	Valve Assembly - 30° - Buna N	143-16-511-10
	Valve Assembly - 30° - Viton	143-16-511-12
24*	1¼" Orifice, Brass	143-16-023-03
	1" Orifice, Brass	143-16-023-02
	¾" Orifice, Brass	143-16-023-01
	½" Orifice, Brass	143-16-023-00
	⅜" Orifice, Brass	143-16-023-04
	¼" Orifice, Brass	143-16-023-10
	.207" Orifice, Brass	143-16-023-11
25	Travel Stop stem	143-16-060-02
26	Warning Tag-Travel Stop	143-16-136-05
27	Warning-Tag-Body Interchangeability	143-16-136-06
28	Clamping Plate	143-16-102-01

Model 243 Regulator Illustrations

243-12-2

IRV Regulator (as shown)

243-12-1

Same as IRV Regulator except no internal relief valve and standard cover cap as shown in inset.

PIPE SIZES

2" flanged ANSI 125 lb FF
1½" and 2" screwed

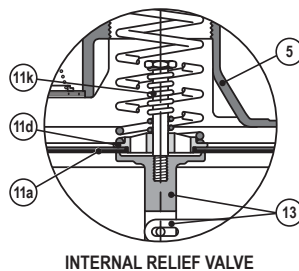
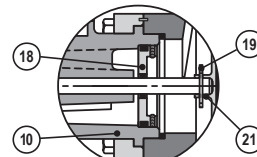
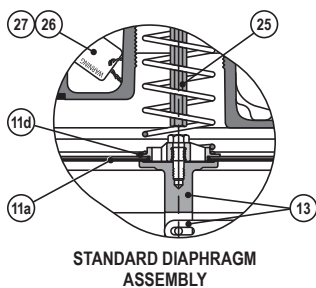
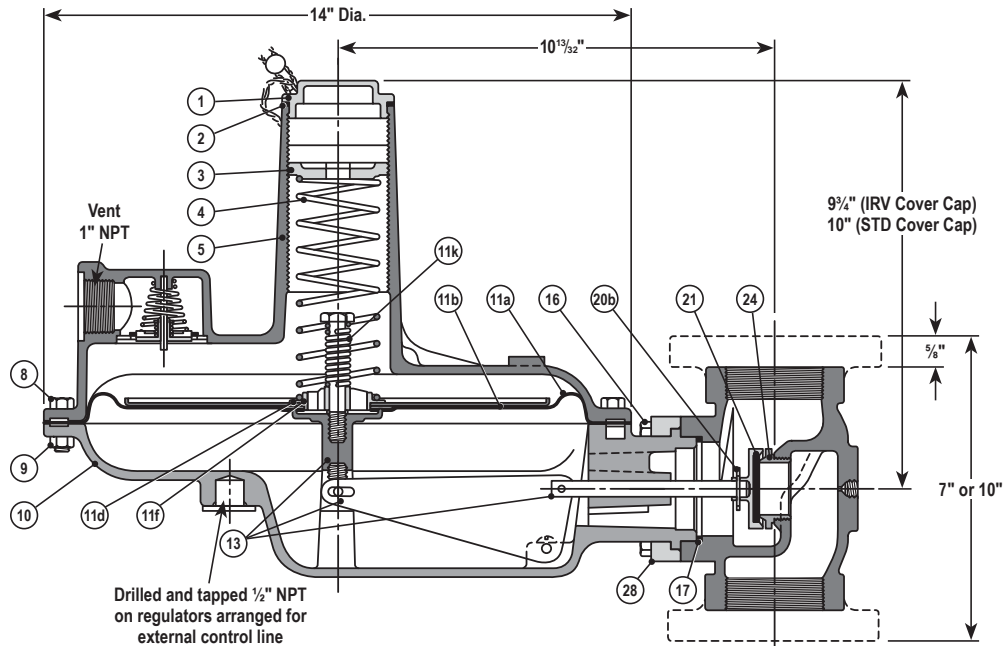
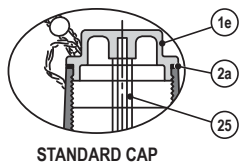

243-8-1

Standard Regulator (as shown)

243-8-2

Same as Standard Regulator except Internal Relief Valve as shown in inset.

PIPE SIZES

2" flanged ANSI 125 lb FF
1¼", 1½" and 2" screwed

243-8HP

Remainder of regulator same as 243-8-1

PIPE SIZES

2" flanged ANSI 125 lb FF
1¼", 1½" and 2" screwed

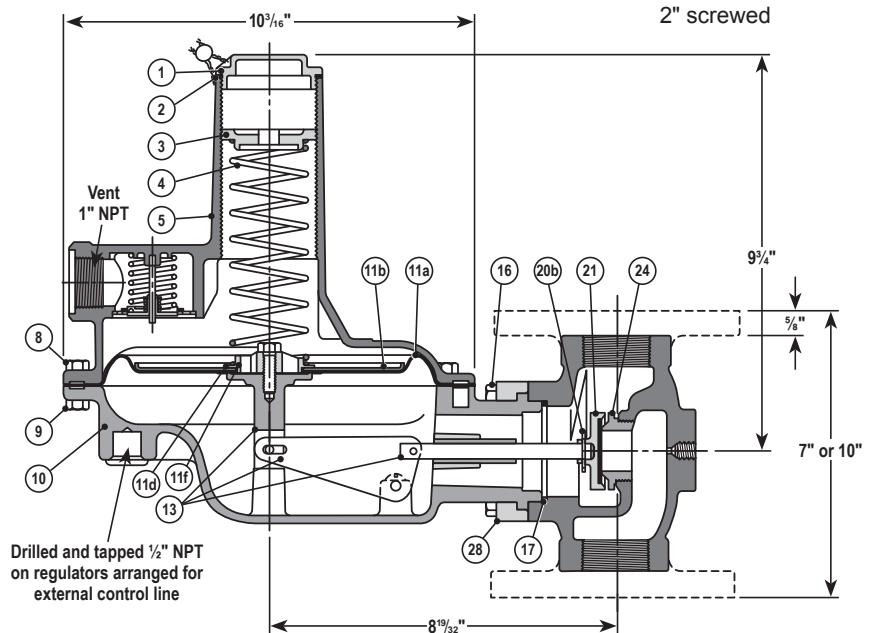
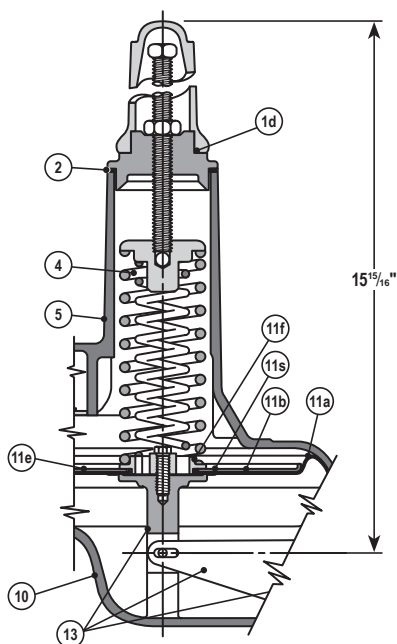

Maximum Emergency Pressures

The maximum pressure the regulator inlet may be subjected to under abnormal conditions without causing damage to the regulator is the maximum allowable inlet pressure (from the table below) plus 50 psi.

The maximum pressure the diaphragm may be subjected to without causing damage to the internal parts of the regulator is:

- 243-12-1 setpoint + 3 psi
- 243-12-2, 243-8-1 and 243-8-2 setpoint + 5 psi
- 243-8HP setpoint + 5 psi

If any of the pressure limits are exceeded, the regulator must be taken out of service and inspected. All damaged or otherwise unsatisfactory parts must be repaired or replaced.

The maximum pressure that can be safely contained by the diaphragm case is:

- 243-12-1 and 243-12-2..... 15 psi
- 243-8-1 and 243-8-2..... 45 psi
- 243-8HP 45 psi

“Safely contained” means no leakage as well as no bursting.

Before using any of the above data, make sure this entire section is clearly understood.

NOTE: The use of an internal or external relief valve is recommended for installations subjected to no flow for extended periods of time, such as pilotless ignition systems. A travel stop stem is located in the 243-12-1 and 243-12-4 to provide overpressurization protection to internal components during overpressurization.

Spring Ranges

Spring Color	Outlet Pressure Range		Spring Part Number
	243-12	243-8	
Red	3½" to 6½" w.c.	—	143-16-021-03
Red-Black	—	3½" to 6½" w.c.	143-82-021-00
Blue	5" to 8½" w.c.	—	143-16-021-04
Blue-Black	—	5" to 8½" w.c.	143-82-021-01
Green-Black	—	6" to 14" w.c.	143-82-021-02
Green	6" to 14" w.c.	12" to 28" w.c.	143-16-021-05
Orange-Black	10" to 18" w.c.	—	143-16-021-11
Orange	12" to 28" w.c.	1 to 2 psi	143-16-021-06
Black	1 to 2 psi	2 to 4¼ psi	143-16-021-07
Cadmium	1½ to 3 psi	3 to 5 psi§	143-16-021-08
Cadmium	1½ to 3 psi	3 to 6½ psi*	143-16-021-08
Cadmium	—	6 to 10 psi*	143-16-021-08
White †	—	6 to 10 psi*	143-16-021-13

† White is nested inside Cadmium *Model 243-8HP only §Model 243-8-2 (IRV) only

Monitoring

Model 243 Regulators make excellent monitors. They can act as standby regulators installed in series and assume control if a failure in the operating regulator permits the outlet pressure to exceed the setpoint. It can be located in either the upstream or the downstream position.

When a Model 243 Regulator is used to monitor a regulator with an identical inner valve (another Model 243 Regulator), the total maximum capacity through both regulators can be figured at 70% of the capacity of one regulator alone. This applies with the monitor located either upstream or downstream.

Full Open Capacity

Use the following formulas for the full open capacity of 243 regulators:

- $Q = K\sqrt{P_o(P_i - P_o)}$ (for $\frac{P_i}{P_o}$ less than 1.894)
- $Q = \frac{KP_i}{2}$ (for $\frac{P_i}{P_o}$ greater than 1.894)

Q = maximum capacity of the regulator (in SCGH of 0.6 specific gravity natural gas).
 K = the “K” factor, the regulator constant (from the table)
 P_i = **absolute** inlet pressure (psia)
 P_o = **absolute** outlet pressure (psia)

Orifice size:	.207"	¼"	⅜"	½"	¾"	1"	1¼"
K	90	132	292	520	1100	1800	2480

Other Gases

243-RPC Regulators are mainly used on natural gas. However, they perform equally well on LP gas, nitrogen, dry CO₂, air and others.

For capacities, multiply the table values on pages 6 thru 22 in Bulletin DS-G-REG-1306 by the following correction factors:

Type of Gas	Correction Factor
Air (Specific Gravity 1.0)	0.77
Propane (Specific Gravity 1.53)	0.63
1350 BTU Propane-Air Mix (Specific Gravity 1.20)	0.71
Nitrogen (Specific Gravity 0.97)	0.79
Dry Carbon Dioxide (Specific Gravity 1.52)	0.63

For other noncorrosive gases use the following formula:

$$\text{CORRECTION FACTOR} = \sqrt{\frac{0.60}{\text{Specific gravity of the gas}}}$$

While used primarily for natural gas services, Model 243 regulators perform equally well on LPG vapor, air, dry CO₂, nitrogen and other inert gas applications. Please contact your Sensus representative for special construction which may be available for certain corrosive gases.

NOTE: The term “standard” refers to non-IRV configurations.

Condensed Capacity Table in SCFH of Natural Gas (0.6 Specific Gravity – 14.65 psia – 60°F)

	INLET PRESSURE psi	ORIFICE SIZE and VALVE ANGLE	OUTLET PRESSURE SETPOINT and SPRING					
			6" w.c. RED SPRING (1" w.c. droop)	7" w.c. BLUE SPRING (1" w.c. droop)	11" w.c. GREEN SPRING (2" w.c. droop)	18" w.c. ORANGE SPRING (3" w.c. droop)	1 psi BLACK SPRING (0.2 psi droop)	2 psi CADMIUM SPRING (0.6 psi droop)
2" 243-12	2	1¼"-30°	6400	6000	5600	4200	3350	—
	5	1¼"-30°	11000	11000	10500	8000	6600	8200
	15	1¼"-30°	14000	14000	14000	13500	13000	15500
	25	1"-30°	15000	15000	15000	16500	15000	18000
	40	¾"-30°	20000	20000	20000	20000	20000	20000
	60	¾"-10°	15000	15000	15500	15000	15500	16500
	100	½"-10°	13000	13000	14000	14000	14000	16000
	125	⅝"-10°	12000	12000	12000	12000	12000	12000
1½" 243-12	2	1¼"-30°	4000	3800	4000	3000	2800	—
	5	1¼"-30°	6100	5700	6000	5600	5500	6000
	15	1¼"-30°	9300	9300	10000	10000	10000	13000
	25	1"-30°	11000	11000	11500	11500	11000	14500
	60	¾"-10°	12000	10500	12500	12500	12500	15000
	100	½"-10°	12000	12000	12500	13000	13000	16000
	125	⅝"-10°	11000	11000	11000	11000	11000	12000
1½" and 2" 243-12 with External Control Line	5	1"-10°	8200	6500	7200	5500	5400	6800
	5	1¼"-10°*	10500	7800	8500	6500	7000	8600
	10	1"-10°	12000	10000	11000	8000	8500	10500
	10	1¼"-10°*	15000	13000	13500	11000	10500	13000
	25	1"-10°	20000	17000	17000	15000	14500	20000
	25	1¼"-10°*	22000	20000	20000	18000	18000	25000
	40	1"-10°	24000	21000	24000	21000	20000	25000
	80	¾"-10°	30000	21000	27000	22000	22000	25000
	100	½"-10°	19000	19000	19000	19000	19000	19000
125	⅝"-10°	15000	15000	15000	15000	15000	15000	

2" size only.

Refer to Bulletin DS-G-REG-1306 for detailed capacity tables and curves.

Condensed Capacity Table in SCFH of Natural Gas (0.6 Specific Gravity – 14.65 psia – 60°F)

	INLET PRESSURE psi	ORIFICE SIZE and VALVE ANGLE	OUTLET PRESSURE SETPOINT and SPRING						
			6" w.c. RED-BLACK SPRING (1" w.c. droop)	7" w.c. BLUE-BLACK SPRING (1" w.c. droop)	18" w.c. GREEN SPRING (3" w.c. droop)	1 psi ORANGE SPRING (0.2 psi droop)	3 psi BLACK SPRING (0.6 psi droop)	5 psi* CADMIUM SPRING (1 psi droop)	10 psi* CADMIUM and WHITE SPRING (0.6 psi droop)
1½" 243-8	2	1"-30°	3200	2700	2100	2100	—	—	—
	10	1"-30°	7400	7000	6600	6500	7100	6000	—
	25	1"-30°	12500	12500	11500	11000	12500	12000	12000
	40	¾"-10°	10500	10500	11000	11000	13000	12000	15000
	80	½"-10°	11500	11500	12000	11500	13500	11000	17000
	100	⅜"-10°	11000	11000	11000	11000	12000	11000	15000
	125	¼"-10°	8000	8000	8000	8000	8000	8000	8000
1¼" 243-8	2	¾"-10°	2250	1700	1900	1850	—	—	—
	10	¾"-10°	3100	2900	2950	2700	3600	3300	—
	25	¾"-10°	4200	4200	4400	4150	5000	4400	9000
	40	¾"-10°	4200	4800	5300	5300	6300	5800	12000
	80	½"-10°	5600	5600	4850	4650	5500	4500	13000
	100	⅜"-10°	6000	6000	6000	6000	6550	6000	13000
	125	¼"-10°	6000	6000	8000	8000	8000	8000	8800
2" 243-8	5	1"-30°			5500	4000	4400	—	—
	10	1"-30°			9400	7000	7600	6000	—
	25	1"-30°			14500	14500	15000	13000	15500
	40	¾"-30°			20000	17500	17500	12000	22000
	80	½"-10°			14000	13500	15000	11500	18500
	100	⅜"-10°			12000	11000	12000	11000	16000
	125	¼"-10°			8000	8000	8000	8000	9000

*243-8HP only.

Refer to Bulletin DS-G-REG-1306 for detailed capacity tables and curves.

243 Service Regulators

Installation and Maintenance Instructions



Authorized Distributor:

All products purchased and services performed are subject to Sensus' terms of sale, available at either <http://na.sensus.com/TC/TermsConditions.pdf> or 1-800-METER-IT. Sensus reserves the right to modify these terms and conditions in its own discretion without notice to the customer.

This document is for informational purposes only, and SENSUS MAKES NO EXPRESS WARRANTIES IN THIS DOCUMENT. FURTHERMORE, THERE ARE NO IMPLIED WARRANTIES, INCLUDING WITHOUT LIMITATION, WARRANTIES AS TO FITNESS FOR A PARTICULAR PURPOSE AND MERCHANTABILITY. ANY USE OF THE PRODUCTS THAT IS NOT SPECIFICALLY PERMITTED HEREIN IS PROHIBITED. © 2013 Sensus.